



STANDARD PROVISIONS
FOR
CONSTRUCTION CONTRACTS

VOLUME 2:
SPECIAL PROVISIONS

October 2017 Edition



MEMORANDUM

TO: Distribution

RECOMMENDED BY: Linda D. Dangerfield, CPPB *Linda D. Dangerfield*
Director, Office of Procurement & Materials Management

APPROVED BY: Paul L. Shank, PE, C.M., Chief Engineer *Paul L. Shank*
Division of Planning and Engineering

DATE: December 13, 2019

SUBJECT: Interim Standard Provisions Addendum (ISPA)
ISPA Number: ISPA-19-001, Liability Insurance

Effective on all projects advertised on or after December 13, 2019, the following modification shall be made to the MAA Standard Provisions for Construction Contracts dated October 2017:

Volume 2, Part 1, Section 3, Paragraph SP-3.02, Paragraph C

Remove Paragraph C in its entirety and replace with new Paragraph C below:

- C. The liability insurance shall under no circumstances be less than TWO HUNDRED THOUSAND DOLLARS (\$200,000) for injuries sustained by any one (1) person, and TWO MILLION DOLLARS (\$2,000,000) for injuries sustained by two (2) or more persons in any one (1) accident. The amount of property damage insurance shall not be less than ONE MILLION DOLLARS (\$1,000,000) or a combined single bodily and property damage limit of not less than FIVE MILLION DOLLARS (\$5,000,000) per accident. The liability insurance shall include comprehensive automobile liability insurance with a combined single limit of FIVE MILLION DOLLARS (\$5,000,000) (including garage liability, all automotive equipment owned, operated, leased, hired, and non-owned) for bodily injury and property damage for each accident. The following insurance amounts are required for vehicles operating on the airfield:
1. Restricted Areas (Non-Movement Area Access – Aircraft Ramp Areas). A limit of not less than Five Million Dollars (\$5,000,000) for each accident.
 2. Restricted Areas (Movement Area Access – Runways and Taxiways). A limit of not less than Ten Million Dollars (\$10,000,000) for each accident.

Said levels of insurance are to cover claims arising solely in connection with this Contract and shall not be subject to any degree of depletion as a result of claims arising in connection with other activities undertaken by the Contractor. Said insurance is to be issued with the Maryland Aviation Administration and its employees, as an additional insured, not as a named insured.

**MDOT MAA STANDARD PROVISIONS FOR CONSTRUCTION CONTRACTS
INTERIM STANDARD PROVISIONS ADDENDUM (ISPA) NUMBER: ISPA-23-001**

DECEMBER 1, 2023

VOLUME 2 SPECIAL PROVISIONS

- A. Part 1, Section 5, Paragraph SP-5.02 – Environmental Protection
- B. Part 1, Section 6, Paragraph SP-6.07– Confined Space Standard Forms

Effective on all projects advertised on or after December 1, 2023, the following modification shall be made to the MAA Standard Provisions for Construction Contracts, dated October 2017:

A. Volume 2, Part 1, Section 5, Paragraph SP-5.02 – Environmental Protection

- 1. Revise Item C as shown in Attachment 1: SP-5.02 Environmental Protection where green text indicates new text and red text indicates revised text (Attachment 1).

B. Volume 2, Part 1, Section 6, Paragraph SP-6.07 – Confined Space Standard Forms

- 1. Remove form *MAA-017C R 1-06, Confined Space Entry Permit* in its entirety (2 pages). Replace with form *MAA-017C R 7/22, Confined Space Entry Permit* (1 page) (Attachment 2).
- 2. Revise the following text for SP-6.07, Item C.9.c from “*Confined Space Entry Critique/Review Sheet*” to “*Acceptable Entry Conditions*”
- 3. Remove form *MAA-017F R 1-06, Confined Space Entry Critique/Review Sheet* in its entirety (1 page) Replace with form *MAA-017F R 7/22, Acceptable Entry Conditions* (1 page) (Attachment 3).



Linda D. Dangerfield, NIGP-CPP, CPPB, Director
Office of Procurement and Materials Management

Tom Varughese, P.E., Director
Division of Planning and Engineering
Office of Engineering and Construction

ISPA-23-001

A. Volume 2, Part 1, Section 5, Paragraph SP-5.02 – Environmental Protection

B. Volume 2, Part 1, Section 6, Paragraph SP-6.07 – Confined Space Standard Forms

Page 2



Paul L. Shank, P.E., C.M., Chief Engineer
Division of Planning and Engineering

ATTACHMENTS:

1. SP-5.02 Environmental Protection
2. MAA-017C R 7/22, MAA Confined Space Entry Permit
3. MAA-017F R 7/22, Acceptable Entry Conditions

DISTRIBUTION

ATTACHMENT 1

SP-5.02 Environmental Protection

C. Environmental Protection Agency's National Pollutant Discharge Elimination System (NPDES) Construction General Permit

On projects involving disturbance of **one (1)** acre or more, a Notice of Intent (NOI) to comply with the General Permit for Stormwater Discharge Associated with Construction Activity (General NPDES Permit Number MDRC0000, State Discharge Permit Number 20CP0000, referred to as "20-CP") in accordance with the Environmental Protection Agency's NPDES stormwater program, will be **submitted to** the Maryland Department of the Environment Water and Science Administration (MDE/WSA) **by the Administration**. The 20-CP authorizes the discharge of stormwater from the project site, in accordance with the Clean Water Act. The 20-CP requires strict compliance with the contract erosion & sediment control and stormwater management plans, including weekly recorded inspections and within 24-hours following a storm event.

Upon **notification from MDE/WSA of coverage under the 20-CP**, the Administration will transfer to the Contractor the responsibilities and requirements of the **20-CP, including any special conditions (as determined by MDE/WSA)**. The Contractor will be responsible for compliance under all terms of the **20-CP including the development and implementation of a Stormwater Pollution Prevention Plan (SWPPP) if applicable to the project**. The Contractor will assume full responsibility of the permitted activities by **completing and submitting to MDE/WSA the Transfer of Authorization process within five (5) calendar days of receiving**. In addition, the Contractor will, in accordance with the **20-CP requirements**, conduct inspections of erosion and sediment controls, **dewatering operations as applicable, and maintain records of these inspections**. Dewatering information and inspection reports shall be submitted to MDE/WSA in accordance with 20-CP requirements. The Contractor shall submit a Notice of Termination upon completion of the construction activity and establishment of final stabilization of the project site, and meet all other obligations described in the 20-CP. Copies of any documentation required by the **20-CP** will be submitted to the **Administration** at the completion of the project. A copy of the **20-CP**, Transfer of Authorization, and Notice of Termination are **to be made available for review at the Administration's Division of Planning & Engineering**.

Note: The **red** denotes text that has been changed and the **green** denotes new text that has been added.

ATTACHMENT 2

MAA0-17C R 7/22, MAA Confined Space Entry Permit

MAA CONFINED SPACE ENTRY PERMIT

Facility: _____ Month: _____ Permit #: _____

Permit Begins: Date: _____ Time: _____ AM/PM Expires: Date: _____ Time: _____ AM/PM

Location of Confined Space: _____

Potential Hazards: _____

Reason for Entry: _____

Pre-Entry Checklist	YES	NO	N/A	Initials
1. Area Secured				
2. Vehicular Traffic re-directed or barricaded				
3. Energy lockout/tagout complete				
4. Lines blinded or disconnected				
5. Proper ventilation supplied				
6. Specialized PPE or safety equipment required				
7. Adequate safety lighting provided				
8. Harness and retrieval line used				
9. Mechanical lifting device available for spaces over five feet in depth				
10. Communication methods specified between attendant and entrant(s): Verbal, radio, visual, hand, other(specify)				
11. Rescue procedures in place or notified				
12. Acceptable entry conditions have been determined (back of permit)				
13. Other hazards: Bacteria, rodents, insects, temperature				
14. Frequency of periodic testing has been specified				
15. Bump test completed				

Emergency Response: _____ Phone Number: _____

Entry Supervisor (Print): _____

Entry Supervisor (Signature): _____

Authorized Entrant(s) Print Names

Attendant(s) Print Names

Standby Personnel:

ATTACHMENT 3

MAA-017F R 7/22, Acceptable Entry Conditions

INTRODUCTION

The *Standard Provisions for Construction Contracts*, consisting of *Volume 1: General Provisions* and *Volume 2: Special Provisions*, are intended to establish uniformity and consistency of specifications in matters of construction contracts. The *Standard Provisions* as referenced by edition date in the Technical Provisions and Bid Forms, are part of the Contract Documents and are binding upon the parties signatory to the Contract. By proposing to undertake a project and submitting a bid, the Contractor agrees that s/he has reviewed, is familiar with, and will abide by the requirements of these *Standard Provisions*.

If the *Standard Provisions* are revised, a new edition date will be provided on the contract CD. Accordingly, the Bid Proposal Section in the Contract Bid Forms will refer to the applicable edition of the *Standard Provisions* for that contract. The prospective contractor is advised to record the correct applicable version of the *Standard Provisions* in the Bid Proposal Section in the Contract Bid Forms.

STANDARD PROVISIONS FOR CONSTRUCTION CONTRACTS SPECIAL PROVISIONS

TABLE OF CONTENTS

PART I SPECIAL PROVISIONS

SECTION 1 DEFINITIONS AND STANDARDS

SP-1.01	Abbreviations	1
SP-1.02	Landside and General Definitions.....	3
SP-1.03	Airport/Airside Related Definitions	8
SP-1.04	Intention of Language and Terms.....	10
SP-1.05	Phonetic Alphabet	11
SP-1.06	Compliance with Laws, Codes and Standards	11
SP-1.07	Captions.....	13

SECTION 2 BIDDING REQUIREMENTS AND CONDITIONS

SP-2.01	Project Classification.....	14
SP-2.02	Preparation of Bid	14
SP-2.03	Corporate Registration.....	15
SP-2.04	Legal Address	16
SP-2.05	Rejection of Bids.....	16
SP-2.06	Contingent Items	17
SP-2.07	Procurement Officer's Representative	17

SECTION 3 LEGAL REQUIREMENTS

SP-3.01	Indemnification of the Maryland Aviation Administration	18
SP-3.02	Compensation, Liability, and Property Damage Insurance	19
SP-3.03	Third Party Beneficiary Clause	20
SP-3.04	Builder's Risk Insurance.....	20
SP-3.05	Insurance Requirements for Asbestos Removal	20
SP-3.06	Bankruptcy Notification	22

SECTION 4 CONSTRUCTION REQUIREMENTS AND CONDITIONS

SP-4.01	Pre-Construction Conference.....	23
SP-4.02	Notice to Proceed	23
SP-4.03	Plans and Specifications Furnished to Contractor	23
SP-4.04	Contractor's Staging Area	23

SP-4.05	Access to Site.....	24
SP-4.06	Federal Aviation Administration Facilities.....	25
SP-4.07	High Structure Approval Procedure.....	25
SP-4.08	Sanitary Provisions.....	25
SP-4.09	Dust Control and Housekeeping.....	25
SP-4.10	Plant/Source Inspection.....	26
SP-4.11	Layout of Work.....	27
SP-4.12	Existing Utilities.....	27
SP-4.13	Temporary Utilities.....	28
SP-4.14	Request for Information Procedures.....	29
SP-4.15	Supervision by the Engineer.....	29
SP-4.16	Burning and Welding Permits.....	30
SP-4.17	Energized Equipment Work Permits.....	30

SECTION 5 CONTROL OF THE WORK

SP-5.01	Archaeological and Historical Findings.....	31
SP-5.02	Environmental Protection.....	31
SP-5.03	Equal or Approved Equal.....	32
SP-5.04	Request for Substitutions.....	33
SP-5.05	Disposal of Excess Material.....	36
SP-5.06	Authority of the Procurement Officer.....	36
SP-5.07	Hazardous Materials.....	36
SP-5.08	Environmental Permits.....	38
SP-5.09	HVACR Licensing Requirements.....	39

SECTION 6 SECURITY AND SAFETY

SP-6.01	BWI Airport Security.....	40
SP-6.02	Martin State Airport Security.....	44
SP-6.03	Safety Requirements During Construction.....	44
SP-6.04	Site Specific Safety Plan.....	50
SP-6.05	Maintenance of Traffic.....	53
SP-6.06	Occupational Exposure to Lead in Construction Work.....	55
SP-6.07	Safety Hazards in Confined Spaces.....	56
SP-6.08	Call-Back Roster.....	68
SP-6.09	Temporary Support of Excavation.....	68

SECTION 7 LIMITATIONS AND RESTRICTIONS

SP-7.01	Use of Explosives.....	85
SP-7.02	Recycled or Rehandled Materials.....	85
SP-7.03	Night Work.....	85
SP-7.04	Saturday, Sunday, and Holiday Work.....	85

SP-7.05	Parking of Vehicles and Construction Limitations	85
SP-7.06	Monitoring Well Permit	86

SECTION 8 EXECUTION AND PROGRESS

SP-8.00	Project Scheduling Requirements	87
SP-8.01	Subcontracting	89
SP-8.02	Schedules	89
SP-8.03	Critical Path Method Schedules	90
SP-8.04	Progress Meetings	105
SP-8.05	Construction Quality Control Plan	105
SP-8.06	Shop Drawings, Product Data, and Samples	110
SP-8.07	Notice to the MAA of Labor Disputes	119
SP-8.08	Record Drawings/As-Built Drawings	120
SP-8.09	Project Completion and Punchlists	120
SP-8.10	Time Extensions for Unusually Severe Weather	121
SP-8.11	Operating and Maintenance Data	122
SP-8.12	Order of Precedence of Specifications/Standard Provisions/Plans.....	123

SECTION 9 PAYMENT

SP-9.01	Hours of Labor, Wages, and Payroll Reporting	124
SP-9.02	Contractor's Invoice	126
SP-9.03	Payment for Stored Materials	126
SP-9.04	Negotiated Payment	127
SP-9.05	Force Account Work	129
SP-9.06	Progress Payments	130
SP-9.07	Prompt Payment to Subcontractors	131

SECTION 10 STANDARD PROVISIONS FORMS

SP-10.01	Request for Information (SP-4.14)	136
SP-10.02	Substitution Request (SP-5.04).....	137
SP-10.03	Subcontractor Statement of Acknowledgement (SP-8.01)	139
SP-10.04	Submittal Register (SP-8.06)	140
SP-10.05	Minority Business Enterprise Utilization Statement (SP-9.02)	141
SP-10.06	Monthly Injury Report (SP-6.04).....	144
SP-10.07	BASE BID SCHEDULE OF VALUES (SP-2.02).....	145
SP-10.08	Energized Equipment Work Permit (SP-4.17).....	146

PART II CONTRACTOR AFFIRMATIVE ACTION PROGRAM AND EQUAL EMPLOYMENT OPPORTUNITY (EEO) PROGRAMS

SECTION 1 OVERVIEW

AAP-1.01	General.....	149
AAP-1.02	Applicability.....	149

SECTION 2 AFFIRMATIVE ACTION/EQUAL OPPORTUNITY PROGRAM

AAP-2.01	Definitions	150
AAP-2.02	Legal Mandates.....	150
AAP-2.03	Assignment of Responsibilities	152
AAP-2.04	Dissemination of Policy	152
AAP-2.05	Recruitment	153
AAP-2.06	Personnel Actions.....	153
AAP-2.07	Training and Promotion.....	154
AAP-2.08	Utilization of Unions	154
AAP-2.09	Utilization of Subcontractors.....	154
AAP-2.10	Records and Reports.....	154
AAP-2.11	Monitoring.....	155
AAP-2.12	Employment Goals and Timetables for Minority and Female Utilization in All Trades	155

PART III MARYLAND MINORITY/DISADVANTAGED BUSINESS ENTERPRISE PROGRAM

SECTION 1 PROGRAM AUTHORITY

MBE-1.01	Program Authority.....	157
----------	------------------------	-----

SECTION 2 EXPLANATION OF TERMS

MBE-2.01	Explanation of Terms.....	161
----------	---------------------------	-----

SECTION 3 SPECIAL PROVISIONS AFFIRMATIVE ACTION REQUIREMENTSUTILIZATION OF DBE/MBE FEDERAL AID CONTRACTS

MBE-3.01	Terms	171
MBE-3.02	Bidders' Action.....	174
MBE-3.03	Records and Reports.....	177
MBE-3.04	Administrative Procedures for Enforcement.....	178

SECTION 4 CONTRACTOR COMPLIANCE

MBE-4.01	Contract Monitoring	180
MBE-4.02	Non-Compliance	181
MBE-4.03	Contract Compliance – Trucking	182

SECTION 5 LARGE COST SUPPLY ITEMS

MBE-5.01	Large Cost Supply Item	186
MBE-5.02	Structural Steel	187

SECTION 6 GOOD FAITH EFFORTS

MBE-6.01	Good Faith Efforts	188
----------	--------------------------	-----

PART IV PROVISIONS FOR FEDERAL-AID CONTRACTS

SECTION 1 FAA REQUIREMENTS

FAA-1.01	Notice of Requirement for Affirmative Action to Ensure Equal Employment Opportunity	198
FAA-1.02	Certification of Nonsegregated Facilities	199
FAA-1.03	Contractor’s Certification of Nonsegregated Facilities	199
FAA-1.04	Access to Records and Reports	199
FAA-1.05	Equal Employment Opportunity Clause	200
FAA-1.06	Standard Federal Equal Employment Opportunity Construction Contract Specifications	202
FAA-1.07	Title VI Clauses for Compliance with Nondiscrimination Requirements	207
FAA-1.08	Standard Requirements for AIP Contracts	209
FAA-1.09	Clean Air and Water Pollution Control Requirements	211
FAA-1.10	Bonding/Insurance	211
FAA-1.11	DBE Requirements	212
FAA-1.12	Trade Restriction Certification	213
FAA-1.13	EEO Notice to be Posted	215

SECTION 2 DAVIS-BACON REQUIREMENTS

FAA-2.01	Minimum Wages	216
FAA-2.02	Withholding	218
FAA-2.03	Payrolls and Basic Records	218
FAA-2.04	Apprentices and Trainees	220
FAA-2.05	Compliance with Copeland Act Requirements	222
FAA-2.06	Subcontracts	223
FAA-2.07	Contract Termination: Debarment	223

FAA-2.08	Compliance with Davis-Bacon and Related Act Requirements	223
FAA-2.09	Disputes Concerning Labor Standards	223
FAA-2.10	Certification of Eligibility	223
FAA-2.11	Contractor’s Certification of Eligibility	224
FAA-2.12	Contract Work Hours and Safety Standards Act Requirements	224

SECTION 3 BUY AMERICAN CLAUSE

FAA-3.01	Notice to Bidders	226
FAA-3.02	List of Supplies/Materials	227
FAA-3.03	Buy American Certification.....	229

SECTION 4 SAMPLE FORMS FOR FEDERAL-AID CONTRACTS

FAA-4.01	Prohibition of Segregated Facilities (FAA-1.03).....	231
FAA-4.02	Contractor’s Certification of Eligibility (FAA-2.11).....	232
FAA-4.03	Buy American Certification (FAA-3.03)	233
FAA-4.04	Contractor’s Certification of a Drug-Free Workplace	237
FAA-4.05	Certification for Federal-Aid Contracts	239
FAA-4.06	Disadvantaged Business Enterprises.....	240
FAA-4.07	Texting When Driving.....	240
FAA-4.08	Occupational Safety and Health Act of 1970	240
FAA-4.09	Procurement of Recovered Materials.....	241
FAA-4.10	Title VI List of Pertinent Nondiscrimination Acts and Authorities	241
FAA-4.11	Copeland “Anti-Kickback” Act	243
FAA-4.12	Energy Conservation Requirements	243
FAA-4.13	Termination for Default (Construction)	243
FAA-4.14	Termination for Default (Equipment)	243

PART I
Special Provisions

SECTION 1

DEFINITIONS AND STANDARDS

SP-1.01 Abbreviations

Wherever the following terms are used in these specifications, in the Contract, in any Documents, or other instruments pertaining to construction where these specifications govern, the intent and meaning shall be interpreted as follows:

ACFAA	Advisory Circular
ADA	Americans with Disabilities Act
AGL	Above Ground Level
ALP	Airport Layout Plan
ALS	Approach Lighting System
API	American Petroleum Institute
ARFF	Aircraft Rescue and Firefighting or CFR
ARP	Airport Reference point
ASDE	Airport Surface Detection Equipment
ASR	Airport Surveillance Radar
ATC	Air Traffic Control
ATCT	Air Traffic Control Tower
AWOS	Automated Weather Observing System
AWS	American Welding Society
AZ	Azimuth
BRL	Building Restriction Line
BWI	Baltimore/Washington International
CBR	California Bearing Ratio
CFR	Code of Federal Regulations
COMLO	Compass Locator
DBE	Disadvantaged Business Enterprise
DME	Distance Measuring Equipment
D/VOR	Doppler/VHF Omni-directional Radio Range Beacon
EEO	Equal Employment Opportunity
FAR	Federal Aviation Regulations
FATO	Final Approach and Takeoff Area
FLOLS	Fresnel Lens Optical Landing System
FOD	Foreign Object Damage
GS	Glide Slope
GVGI	Generic Visual Slope Indicator
HIRL	High Intensity Runway Lights
ICEA	Insulated Cable Engineers Association
IES	Illuminating Engineering Society
IFR	Instrument Flight Rules
ILS	Instrument Landing System

IM	Inner Marker Beacon
IMC	Instrument Meteorological Conditions
JMF	Job Mix Formula
LDIN	Lead-In Lighting Systems
LIRL	Low Intensity Runway Lights
LIRS	Low Impact Resistant Supports
LITL	Low Intensity Taxiway Lights
LLWAS	Low Level Wind Shear Alert System
LOC	Localizer
MAA	Maryland Aviation Administration
MALS	Medium (Intensity) Approach Lighting System
MALSF	Medium (Intensity) Approach Lighting System with (sequenced) Flashes
MALSR	Medium (Intensity) Approach Lighting System with "RAILS"
MBE	Minority Business Enterprise
MDOT	Maryland Department of Transportation
MIRL	Medium Intensity Runway Lights
MITL	Medium Intensity Taxiway Lights
MLS	Microwave Landing System
MM	Middle Marker Beacon
MOSHA	Maryland Occupational Safety and Health Administration
MSL	Mean Sea Level
MTN	Martin State Airport
NACE	National Association of Corrosion Engineers
NAVAID	Electronic and Visual Air Navigational Aids
NCMA	National Concrete Masonry Association
NOTAM	Notice to Airmen
NPDES	National Pollutant Discharge Elimination System
NSF	National Sanitation Foundation
NTP	Notice to Proceed
ODALS	Omnidirectional Approach Lighting Systems
OFZ	Obstacle Free Zone
OFA	Object Free Area
OM	Outer Marker Beacon
PAPI	Precision Approach Path Indicator
PAR	Precision Approach Radar - previously referred to as "GCA" (Ground Controlled Approach)
PCC	Portland Cement Concrete
PCI	Portland Cement Association
RAILS	Runway Alignment Indicator Lighting System - 7 sequenced flashing lights spaced
REIL	Runway End Identification Lights
REILS	Runway End Identifier Lighting System
RPZ	Runway Protection Zone
RSA	Runway Safety Area
RVR	Runway Visual Range
R/W	Runway

SMGCS	Surface Movement Guidance and Control System
SHA	State Highway Administration (Maryland)
STI	Steel Tank Institute
TDZ	Touchdown Zone
TERPS	Terminal Instrument Procedures
TSA	Taxiway Safety Area
TVOR	Terminal Very High Frequency Omnidirectional Range
T/L	Taxilane
T/W	Taxiway
UL	Underwriters Laboratories Incorporated
USGS	United States Geological Service
VASI	Visual Approach Slope Indicator
VFR	Visual Flying Rules
VOR	VHF Omni-range Radio Beacon

SP-1.02 Landside and General Definitions

Access Road The right-of-way, the roadway, and all improvements constructed thereon connecting the airport to a public highway.

Administration The term shall be construed to be the Maryland Department of Transportation, Maryland Aviation Administration as established in conformance with the laws of Maryland.

Agreement The Agreement between the Contractor and the Administration, which is a document forming a part of the Contract.

Advertisement A public announcement, as required by local law, inviting bids for work to be performed and materials to be furnished.

Airport Improvement Program (AIP) The federal-aid program which provides Federal funding for eligible airport development projects.

Airside A general term denoting the secure area of the airport grounds and buildings accessible by personnel having security clearance and airport issued security badge.

Base Course The one or more layers of specified material and thickness placed on a subbase or a subgrade to support a surface course.

Bid Total The aggregate sum of all the bid items.

Bridge A structure including supports erected over a depression or an obstruction, such as water, highway, or railway, and having a track or passageway for carrying vehicular or pedestrian traffic or other moving loads. Any bridge or highway grade separation structure shall embrace the substructure and superstructure and the approaches thereto, and such

entrance plazas, interchanges, overpasses, underpasses, connecting highways and other structures.

Certification A document which states that the material and or work complies with the applicable specifications, and includes the actual test results to confirm the statement. The contents of the certification shall be on the Contractor's, vendor's, or manufacturer's letterhead or approved document and shall be duly signed by a company officer. Certifications for metal products when required shall include a statement that the material was melted and manufactured in the United States.

Contract Time The number of working days, calendar days or a calendar date specified in the Contract Documents indicating the time period allowed for the completion of the Contract work.

Consultant Consultant Engineer or firm under contract to the Maryland Aviation Administration.

Drainage Ditch In general, any open water course other than gutters, constructed as indicated in the Contract Documents.

Equipment All machinery, tools, and apparatus necessary for the proper construction and acceptable completion of the work, together with the necessary supplies for upkeep and maintenance.

Extra Work (Change) Work which was not required or provided for in the original contract.

Extra Work Order (Change Order) A written document amending the Contract by adding, deleting, or modifying the Contract to include price, time and/or work and/or conditions not previously addressed within the Contract.

Federal Agencies Reference to any Federal agency or officer shall be deemed made to any agency or officer succeeding in conformance with law to the powers, duties, jurisdictions and authority of the agency or officer mentioned.

Federal Specifications The Federal Specifications and Standards, and supplements, amendments, and indices thereto as prepared and issued by the General Services Administration of the Federal Government. They may be obtained from the Specifications Activity, Printed Materials Supply Division, Building 197, Naval Weapons Plant, Washington, DC 20407.

General Provisions Contract provisions published as part of, or as a supplement to the Standard Provisions intended for general application and repetitive use.

Interim Standard Provisions Addenda (ISPA) Additions and revisions to the Standard Provisions and any published supplements to the Standard Provisions. ISPA shall govern over pertaining and applicable Standard Provisions and published supplements.

Landside A general term denoting the areas and buildings accessible by public not requiring security clearance and security badge.

Laboratory The official testing laboratories of the owner or such other laboratories as may be designated by the Engineer.

Lump Sum Lump Sum shall include all work, labor materials, services, equipment, etc., required to complete the project for a Lump Sum bid price.

Median The portion of a divided highway separating the traveled ways for traffic in opposite directions.

Mobilization/Demobilization The initial transporting of all construction equipment required to perform work herein specified to the project site, and the final transporting of all construction equipment from the project site upon final inspection and acceptance of the project and/or any other items called out as such by the Engineer.

Owner (Sponsor) The term owner shall mean the party of the first part or the contracting agency signatory to the Contract. For AIP contracts, the term sponsor shall have the same meaning as the term owner.

Pavement Structure The combination of subbase, and/or base course, and surface course placed on a subgrade to support and distribute the traffic load to the roadbed.

Plans The official drawings issued by the Administration as part of the Contract Documents, including those incorporated in the Contract Documents by reference. These include the official approved plans, profiles, typical cross sections, working drawings and supplemental drawings or exact reproduction which show the location, character, dimensions and details of the work to be done.

Profile Grade The trace of a vertical plane intersecting the top surface of the proposed wearing surface usually along the longitudinal center line of the roadway. Profile grade means either elevation or gradient of the vertical plane.

Project Manager The individual designated by the Contractor to manage the firm's services related to a particular project. Normally, these services include administrative as well as technical responsibilities.

Punchlist Original contract or change order work items identified by the Engineer at or prior to final inspection which are unsatisfactory, unacceptable and/or incomplete.

Ramp A connecting roadway between two intersecting highways at a highway separation.

Recommended Award The written notification to the apparent successful bidder of the intent of this Administration to enter into a contract contingent upon Board of Public Works or other required approvals.

Right-of-Way The area which has been acquired and/or reserved by the Administration for use in constructing the proposed improvement and appurtenances.

Road or Highway Both the word road and the word highway include rights of way, surfaces, subgrades, shoulders, median dividers, drainage facilities and structures, roadway cuts, roadway fills, traffic barriers, bridges, highway grade elimination structures, tunnels, overpasses, underpasses, interchanges, entrance plazas, approaches and other structures forming an integral part of a street, road, or highway; including bicycle and walking paths and related storm water management facilities and structures. Any other property acquired for the construction, operation, or use of the highway.

Roadside A general term denoting the area adjoining the outer edge of the roadbed within the right-of-way. Extensive areas between the roadways of a divided highway may also be considered roadside.

Shop Drawings Drawings, diagrams, illustrations, schedules, performance charts, brochures, and other data prepared by the Contractor or any subcontractor, manufacturer, supplier or distributor, which illustrates how specific portions of the work shall be fabricated and/or installed.

Shoulder The portion of the roadbed contiguous with the traveled way for accommodation of stopped vehicles, for emergency use and for lateral support of base and surface courses (See SP 1.03 for the Airside definition).

Slopes The inclined graded areas beyond the shoulder and extending from the shoulders to the natural undisturbed surface of the ground.

Special Provisions Contract provisions published as part of, or as a supplement to the Standard Provisions intended for specific requirements peculiar to the Administration.

Specifications The definitions, description, directions, provisions, and requirements contained in a Contract herein, and all written supplements thereto, made or to be made pertaining to the Contract and the materials and workmanship to be furnished under the Contract.

Standard Provisions The most current book entitled "Standard Provisions for Construction Contracts", published by the Administration and intended for general application and repetitive use. Standard Provisions includes but is not limited to the General Provisions, Special Provisions, Contractor Affirmative Action Program, Minority Business Enterprise Program, Provisions for Federal-Aid Contracts, and Sample Contract and Bid Forms.

Structures Buildings, bridges, culverts, catch basins, drop inlets, retaining walls, cribbing, manholes, endwalls, sewers, service pipes, underdrains, foundation drains, steps, fences and other features which may be encountered in the work and not otherwise classed.

Subbase The layers of specified or selected material of designed thickness placed on a subgrade to support a base course or surface course.

Subgrade The top surface of a roadbed upon which the pavement structure, shoulders, and curbs are constructed.

Substantial Completion The stage in the progress of the Contract when the work or designated portion thereof is sufficiently complete in accordance with the requirements of the Contract so the Owner can occupy or utilize the work for its intended use.

Substructure All of that part of the structure above bottoms of bearings of simple and continuous spans, skewbacks of arches and tops of footings of rigid frames, except as noted above for substructure.

Surface Course One or more layers of a pavement designed to accommodate the traffic load.

Superintendent The Contractor's representative at the worksite who is responsible for the continuous field supervision, coordination, completion of the work, and the prevention of accidents, unless another person is designated in writing by the Contractor.

Technical Provisions A document published by the Administration intended for specific requirements particular to an individual project. Technical Provisions include General Information, ISPA, Technical Specifications, Wage Rates, and Bid Forms suitable for bidding.

Technical Specifications The construction, materials, methods, equipment, condition, prerequisites, and qualifications -inclusive of all referenced standards, codes, and regulations- intended for specific requirements specific to an individual project. Standards for specifying materials or testing which are cited in the Contract Specifications by reference shall have the same force and effect as if included in the Contract physically.

Trench An excavation made for the purpose of installing or removing pipes, drains, catch basins, etc. and which is later refilled.

Unit Price Unit Price shall include a price in dollars and cents for each pay item listed. The respective unit prices and quantities written in columns provided for that purpose, will constitute the "bid total".

Utility Services necessary to make the facility operational and should include, but are not limited to providing heating, air conditioning, lighting, communications, sanitary facilities, water, and power in an acceptable manner or standard as required by the Engineer.

Working Day A calendar day upon which, in the judgment of the Engineer, weather and soil conditions are such that the Contractor can advantageously work more than half of his/her current normal force for more than five consecutive hours on a controlling operation.

Working days will not be charged on Saturdays, Sundays and State recognized holidays unless the Contractor actually works more than five hours on a controlling operation.

Working Drawings Stress sheets, shop drawings, fabrication details, erection plans, plans for false work, forms, centering, cribs, cofferdams and masonry layouts, bending and placing drawings, and bar schedules for reinforcement steel and any other supplementary plans or similar data which the Contractor may be required to furnish.

SP-1.03 Airport/Airside Related Definitions

Accelerated-Stop Distance Available (ASDA) The runway plus Stopway (SWY) length declared available and suitable for the acceleration and deceleration of an airplane aborting takeoff.

Aircraft Parking Positions Part of apron (ramp) area used for parking aircraft to enplane and deplane passengers, load or unload cargo.

Aircraft Service Areas Part of apron (ramp) area on or adjacent to an aircraft parking position. Area used by airline personnel/equipment for servicing aircraft and staging of baggage, freight, and mail for loading and unloading of aircraft.

Airport Elevation The highest point of an airport's usable runway expressed in feet above MSL.

Airport Layout Plan (ALP) The plan of an airport showing the layout of existing and proposed airport facilities.

Air Operations Area (AOA) Any area of the airport used or intended to be used for the landing, takeoff, or surface maneuvering of aircraft. An AOA shall include such paved or unpaved areas that are used or intended to be used for the unobstructed movement of aircraft in addition to its associated runway, taxiway, or apron.

Airport Reference Point (ARP) The latitude and longitude of the approximate center of the airport.

Apron (Ramp) The area and facilities used for aircraft gate parking and aircraft support and servicing operations.

Blast Fence A barrier used to divert or dissipate jet blast or propeller wash.

Building Area An area on the airport to be used, considered, or intended to be used for airport buildings or other airport facilities or rights-of-way together with all airport buildings and facilities located thereon.

Building Restriction Line (BRL) A line which identifies suitable building area locations on airports.

Clearway (CWY) A defined rectangular area beyond the end of a runway cleared or suitable for use in lieu of runway to satisfy takeoff distance requirements.

Drainage System The system of pipes, ditches, and structures by which surface or subsurface waters are collected and conducted from the airport area.

Lighting A system of fixtures providing or controlling the light sources used on or near the airport or within the airport buildings. The field lighting includes all luminous signals, markers, floodlights, and illuminating devices used on or near the airport or to aid in the operation of aircraft landing at, taking off from, or taxiing on the airport surface.

Hold Point A location where the air traffic controller could be expected to hold a taxiing aircraft.

Landing Distance Available (LDA) The runway length declared available and suitable for a landing airplane.

Low Visibility Operations The movement of the aircraft on the airport when the visibility conditions are reported to be less than 1,200 feet RVR.

Movement Area The runways, taxiways, and other areas of an airport/heliport which are utilized for taxiing and hover taxiing, air taxiing, takeoff, and landing of aircraft, exclusive of aprons and aircraft parking areas. Entry onto the movement areas must be obtained from ATCT.

Non-Movement Area Taxiways and apron areas not under the control of ATC.

Object Includes but is not limited to above ground structures, NAVAIDs, people, equipment, vehicles, natural growth, terrain, and parked aircraft.

Object Free Area (OFA) A two dimensional ground area surrounding runways, taxiways, and taxilanes which is clear of objects except for objects whose location is fixed by function.

Obstacle Free Zone (OFZ) The airspace defined by the runway OFZ, as appropriate, the inner-approach OFZ and the inner-transitional OFZ, which is clear of object penetrations other than frangible NAVAIDs (NAVAIDs whose properties allow it to fail at a specified impact load).

Runway (R/W) The area on the airport prepared for the landing and takeoff of aircraft.

Service/Fire Lanes Identified rights-of-way on the apron (ramp) designated for aircraft ground service vehicles and fire equipment.

Shoulder An area adjacent to the edge of paved runways, taxiways, or apron providing a transition between the pavement and the adjacent surface; support for the aircraft running off the pavement; enhanced drainage; and blast protection.

Stopway (SWY) A defined rectangular surface beyond the end of a runway prepared or suitable for use in lieu of runway to support an airplane, without damage to the airplane, during an aborted takeoff.

Takeoff Run Available (TORA) The runway length declared available and suitable for the ground run of an airplane taking off.

Takeoff Distance Available (TODA) The TORA plus the length of any remaining runway and/or Clearway (CYW) beyond the far end of TORA.

Taxilane (T/L) Reserved to provide taxiing aircraft with access to and from parking positions.

Taxiway (T/W) A defined path established for the taxiing of aircraft from one part of an airport to another.

Taxiway Safety Area (TSA) A defined surface alongside the taxiway prepared or suitable for reducing the risk of damage to an airplane unintentionally departing the taxiway.

Threshold (TH) The beginning of that portion of the runway available for landing. When the threshold is located at a point other than at the beginning of the pavement, it is referred to as either a Displaced or Relocated Threshold depending on how the pavement behind the threshold may be used.

Threshold (Displaced) The portion of pavement behind a displaced threshold may be available for takeoffs in either direction and landings from the opposite direction.

Threshold (Relocated) The portion of pavement behind a relocated threshold is not available for takeoffs or landings. It may be available for taxiing of aircraft.

SP-1.04 Intention of Language and Terms

- A. Whenever, in these Specifications, Technical Provisions and/or on the Contract Drawings, the words "directed," "required," "permitted," "ordered," "designated," "prescribed," or words of the like import are used, it shall be understood that the direction, requirement, permission, order, designation, or prescription of the Engineer is intended; and similarly, the words "approved," "acceptable," "satisfactory," or words of like import, shall mean approved by, or acceptable to, or satisfactory to the Engineer, subject in each case to the final determination of the Owner.
- B. In addition, it shall be understood that when all such expressions such as "directed, specified, authorized, permitted, approval, acceptable or satisfactory" are used they are implicitly followed by the words "by the Engineer" or "to the Engineer".

- C. Any reference to a specific requirement of a numbered paragraph of the Contract specifications or a cited standard shall be interpreted to include all general requirements of the entire section, specification item, or cited standard that may be pertinent to such specific reference.

SP-1.05 Phonetic Alphabet

Following is a list of phonetic alphabet used by ATCT when referring to specific taxiways on the airfield:

A:	Alfa	I:	India	Q:	Quebec	Y:	Yankee
B:	Bravo	J:	Juliet	R:	Romeo	Z:	Zulu
C:	Charlie	K:	Kilo	S:	Sierra		
D:	Delta	L:	Lima	T:	Tango		
E:	Echo	M:	Mike	U:	Uniform		
F:	Foxtrot	N:	November	V:	Victor		
G:	Golf	O:	Oscar	W:	Whiskey		
H:	Hotel	P:	Papa	X:	Xray		

SP-1.06 Compliance with Laws, Codes and Standards

- A. The Bidder or Contractor shall have made himself/herself familiar with all federal, state, local, and municipal laws, ordinances, rules, codes, regulations, permits and project specific environmental document findings which in any manner affect those engaged or employed in the work, or the materials or equipment used in or upon the work, or in any way affect the work; and no plea of misunderstanding will be considered on account of the ignorance thereof. If the Bidder or Contractor shall discover any provision in the plans, specifications, or other Contract Documents which is contrary to, or inconsistent with any such law, ordinance, rule, regulation, or work permit, he/she shall immediately report it to the Engineer in writing.
- B. The Contractor shall perform all phases of the Contract work in accordance with but not limited to the latest editions of the following codes, standards and regulations adopted by the State as of the time of Bid:
1. International Building Code (IBC)
 2. International Existing Building Code (IEBC)
 3. NFPA 101 Life Safety Code
 4. NFPA 1 Uniform Fire Code
 5. Maryland Fire Prevention Code

6. ADA Standards for Accessibility Design
7. Maryland Accessibility Code (MAC)
8. International Mechanical Code (IMC)
9. International Plumbing Code (IPC)
10. NFPA-70 National Electric Code (NEC)
11. National Fuel Gas Code, ANSI-Z223.1, NFPA-54
12. International Energy Conservation Code (IECC)
13. Federal and Maryland Occupational Safety and Health Administration Regulations (OSHA and MOSH)
14. COMAR Volume XXIII Title 26 Environment Parts 1 and 2
15. COMAR Volume IV Title 08 Natural Resources Part 1
16. COMAR Volume IVA Title 08 Natural Resources Part 2
17. Regulations, governing elevators, dumbwaiters, escalators, and moving walks, ANSI-A17-11, of the latest edition and other requirements of the State Department of Licensing and Regulation, Division of Labor and Industry

C. The latest editions of the following documents, at the time of bid, are hereby included as Contract Documents by reference:

1. Book of Standards, Highways and Incidental Structures, Maryland Department of Transportation, State Highway Administration;
2. Standard Specifications for Construction and Materials, Maryland Department of Transportation, State Highway Administration;
3. Manual on Uniform Traffic Control Devices (MUTCD) of the latest edition as issued by the United States Department of Transportation, Federal Highway Administration and additional requirements as specified by the Maryland State Highway Administration.
4. Erosion and Sediment Control, Maryland Department of Transportation, State Highway Administration;

5. Maryland Standards and Specifications for Soil Erosion and Sediment Control, published jointly by Water Resources Administration, Soil Conservation Services, and State Soil Conservation Committee;
 6. Federal Aviation Administration Standards for Specifying Construction of Airports, Advisory Circulars.
- D. Full compliance with all applicable codes, standards and regulations shall be a minimum requirement for all work to be performed under the Contract. In the event that the Contract Documents include more stringent requirements than applicable codes, standards and regulations, the more stringent requirements shall prevail.
- E. Notwithstanding the use of liquidated damages, the State reserves the right to terminate the contract and exercise all other rights and remedies provided in the contract or by law in the event of noncompliance with all applicable codes, standards and regulations.

SP-1.07 Captions

Captions for all sections of this Contract, except in definitional sections are for ease of reference only and are of no significance in interpreting the meaning of the prose content of the Contract.

SECTION 2 BIDDING REQUIREMENTS AND CONDITIONS

SP-2.01 Project Classification

- A. The Administration will estimate the cost of the Contract and classify it as falling within one of a series of cost groups, each of which will be designated by a letter as follows:

<u>Estimate</u>	<u>Class</u>
Up to \$100,000	A
\$100,000 to \$500,000	B
\$500,000 to \$1,000,000	C
\$1,000,000 to \$2,500,000	D
\$2,500,000 to \$5,000,000	E
\$5,000,000 to \$10,000,000	F
\$10,000,000 to \$15,000,000	G
Over \$15,000,000	H

- B. The letter designations will be published as part of the Notice to Contractors.

SP-2.02 Preparation of Bid

- A. All Contractors and Subcontractors are hereby instructed to conform to the requirements outlined in the contract plans and specifications for supplies, materials, goods, and services, as a basis for the preparation of all bids including alternates (add or deduct/delete).
- B. **The failure to comply with this requirement may result in the disqualification of the subject bid.**
- C. Should a disqualification occur as a result of the Contractor's failure to comply with this requirement, no claim of any sort shall be made or allowed for the reimbursement of any cost associated with the preparation of the bid, or any other cost associated with preliminary Construction and Engineering work.
- D. Schedule of Values:
1. Within forty-eight (48) hours from bid opening, the apparent low bidder shall complete and deliver to the Administration the Base Bid Schedule of Values form (**SP-10.07**). The completed Base Bid Schedule of Values form will be utilized by the Administration to determine compliance with the general contractor self-performance requirements specified in General Provision

GP-8.01-Subcontracting. In addition, the completed Base Bid Schedule of Values shall not be revised without the approval of the Administration, and shall serve as the basis for the Detailed Schedule of Values described in paragraph D. of this **SP-2.02**.

2. The Detailed Schedule of Values shall be prepared by the Contractor and included as a part of the Detailed Schedule #1 submission required by Special Provision **SP-8.03-Critical Path Method Schedules**. The Detailed Schedule of Values shall serve as the basis for cost loading the Detailed Schedule #2 submission required by Special Provision **SP-8.03-Critical Path Method Schedules**. The Detailed Schedule of Values shall be in the same format as the Base Bid Schedule of Values, with the following additional information:
 - a. Each of the CSI format Divisions on the Base Bid Schedule of Values form shall be further subdivided by the individual technical specifications under that Division that have been included as part of the work under the Contract.
 - b. The cost for work to be performed under each technical specification shall be dispersed between the categories of General Contractor, labor and materials; and Subcontractor, labor and materials.
 - c. The cumulative category totals for technical specifications shall be equal to the respective Division category totals indicated on the Base Bid Schedule of Values form and the cumulative cost totals for the technical specifications shall be equal to the respective Division totals indicated on the Base Bid Schedule of Values form.

SP-2.03 Corporate Registration

- A. A Corporation not incorporated in the State of Maryland is considered to be a foreign corporation and, therefore, is required to be registered with the Maryland State Department of Assessments and Taxation, in order to operate in the State (**Section 7-203** of the Corporation Article of the Annotated Code of Maryland).
- B. If the bidder is not currently registered, his/her bid shall be accompanied by a certificate that if notified of his/her recommended award of the Contract, he/she will register and provide a copy of his/her Qualification Acknowledgement along with the executed Contract.

SP-2.04 Legal Address

- A. The address given in the Bid or Proposal is hereby designated as the legal address of the Contractor. Such address may be changed at any time by notice in writing delivered to the Engineer. The delivering at such legal address or the depositing in any post office, in a post-paid registered wrapper directed to the above-named address, of any notice, letter, or other communication to the Contractor, shall be deemed to be legal and sufficient service thereof upon the Contractor.
- B. The delivering at, or the mailing to, the Contractor's business address (written notice of which address shall be given to the Engineer), or the delivering to the Contractor in person or to his/her authorized representative, of any written notice, letter, or other written communication shall also be, and shall be deemed to be, a legal and sufficient service thereof upon the Contractor.

SP-2.05 Rejection of Bids

- A. The following requirements are in addition to the provisions outlined in **GP-2.17** of the General Provisions.
- B. Any proposal having the following faults will be considered irregular and subject to rejection:
 - 1. If the total Bid Price is more than Fifty Thousand Dollars (\$50,000), Bid Forms, Section 1, Bid Bond from the Surety guaranteeing that Performance and Payment Bonds will be furnished is not executed and submitted at the time and date bids are due.
 - 2. If Bid Forms, Section 2, Bid/Proposal Affidavit is not executed and submitted prior to recommended award.
 - 3. If Bid Forms, Section 3, Minority Business Enterprise Utilization Affidavit is not executed and submitted at the time and date bids are due.
 - 4. If Bid Forms, Section 4, Subcontract Utilization Affidavit is not executed and submitted at the time and date bids are due.
 - 5. If Federal-Aid Contract Forms, Certification for Federal-Aid Contracts, is not executed and submitted at the time and date bids are due.
 - 6. If Federal-Aid Contract Forms, Buy American Certificate, is not executed and submitted at the time and date bids are due.
 - 7. If the Contractor fails to acknowledge receipt of all addenda in the space provided in the Proposal Section.

8. If the Contractor fails to acknowledge possession of the specified Standard Provisions for Construction Contracts by Volume and Date in the space provided in the Bid Proposal Section.

SP-2.06 Contingent Items

- A. Construction items for which quantities are identified in the "Summary of Quantity" sheet of the Contract Documents in the column headed "Contingent" or listed in the "Proposal Section of Bids Form", are established for the purpose of obtaining bids on one or more pay items that may be incorporated into the project.
- B. The Engineer shall have sole discretion in determining whether and to what extent such items will be incorporated into the project.
- C. The Engineer may order incorporation of such items at any location within the Contract and at any time during the work. These items may not be located on the Contract Documents. The estimated quantities set out in the Proposal Section of Bid Forms for such items are presented solely for the purpose of obtaining a representative bid price. The actual quantities employed may be only a fraction of, or many times the estimated quantity. The Contractor shall make no claim for additional compensation because of any increase, decrease or elimination of such items.

SP-2.07 Procurement Officer's Representative

The Contractor will be notified in writing by the Procurement Officer of the identity of his/her duly "authorized representative" within the meaning of **GP-1.03**, Organizational Definitions.

SECTION 3 LEGAL REQUIREMENTS

SP-3.01 Indemnification of the Maryland Aviation Administration

- A. The Contractor shall pay, indemnify, and save harmless the Maryland Aviation Administration, the Maryland Department of Transportation, the State of Maryland, the Engineer, their agents and employees, from all suits, actions, claims, demands, damages, losses, expenses, and/or costs of every kind and description to which the Maryland Aviation Administration, the Maryland Department of Transportation, the State of Maryland, the Engineer, their agents and employees, may be subjected to or put by reason or injury (including death) to persons or property resulting from the manner or method employed by the Contractor, his/her agents and employees, or subcontractors, or from any neglect or default of the Contractor, his/her agents or employees, or subcontractors, in the performance of the Contract, or any part thereof, or from, by or an account of, any act or omission of the Contractor, his/her agents and employees, or subcontractors, and whether such suits, actions, claims, demands, damages, losses, expenses, and/or costs be against, suffered or sustained by the Maryland Aviation Administration, the Maryland Department of Transportation, the State of Maryland, the Engineer, their agents and employees. The whole or so much of the monies due or to become due the Contractor under the Contract, as may be considered necessary by the Maryland Aviation Administration, may be retained by the MAA until such suits or claims for damages or injuries shall have been settled or otherwise disposed of, and satisfactory evidence to that effect furnished to the Engineer.
- B. The Contractor shall also agree to indemnify, protect, and save harmless the State, its officers, agents and employees with respect to any claim, action, cost of judgment, and patent infringement arising out of the purchase or use of materials, supplies, equipment or services covered by this Contract.
- C. Furthermore, the Contractor agrees to indemnify, protect and save harmless the State, its officers, agents and employees with respect to any claim, action, cost, or judgment arising from any dispute concerning the validity of any patent which in any way relates to the process that is required by the specifications for the removal, or disposition, of asbestos as more specifically set forth in the Contract Specifications. This indemnification obligation is not limited by, but is in addition to, the insurance obligations and performance bonds contained in this Contract.
- D. Whenever the Contractor is required by any existing Federal, State, local, and/or municipal laws, ordinances, rules or regulations, or by any Federal, State, local, and/or municipal laws, ordinances, rules or regulations that may be enacted hereafter pertaining to the work to be done under this Contract, to secure any permits or licenses to carry any operations in connection with the performance of this Contract,

and/or to act under the direction or supervision of the Engineer and/or his/her representatives in connection with any such operation or operations, the Contractor shall be solely liable for all suits, actions, costs, and damages of every kind and description resulting or which may result, directly or indirectly, from any such operation or operations, and shall indemnify and save harmless the Maryland Aviation Administration, the Maryland Department of Transportation, the State of Maryland, and the Engineer, their agents and employees from any and all suits, actions, costs, and damages of every kind and description arising or which may arise, directly or indirectly, from the said operation or operations.

SP-3.02 Compensation, Liability, and Property Damage Insurance

- A. Except as otherwise provided by law, the Contractor shall at all times maintain and keep in force: such insurance as will protect him/her from claims under Worker's Compensation Acts, and a Certificate of such insurance shall be delivered within ten (10) days after the date of recommended award of the Contract and approved by the Engineer before any work is begun.
- B. The Contractor shall, at his/her own cost, obtain and maintain such insurance as will protect him/her and the Maryland Aviation Administration and its employees on an occurrence basis from, and provide legal representation to address, any claims for damages and personal injury, which may arise from the operations under this Contract, whether such operations be by the Contractor or any subcontractor or by any one directly or indirectly employed by them.
- C. The liability insurance shall under no circumstances be less than TWO HUNDRED THOUSAND DOLLARS (\$200,000) for injuries sustained by any one (1) person, and TWO MILLION DOLLARS (\$2,000,000) for injuries sustained by two (2) or more persons in any one (1) accident. The amount of property damage insurance shall not be less than ONE MILLION DOLLARS (\$1,000,000) or a combined single bodily and property damage limit of not less than FIVE MILLION DOLLARS (\$5,000,000) per accident. The liability insurance shall include comprehensive automobile liability insurance with a combined single limit of FIVE MILLION DOLLARS (\$5,000,000) (including garage liability, all automotive equipment owned, operated, leased, hired, and non-owned) for bodily injury and property damage for each accident. Said levels of insurance are to cover claims arising solely in connection with this Contract and shall not be subject to any degree of depletion as a result of claims arising in connection with other activities undertaken by the Contractor. Said insurance is to be issued with the Maryland Aviation Administration and its employees, as an additional insured, not as a named insured.
- D. The property damage insurance which the Contractor shall provide in its name shall also cover the collapse of, or structural injury to, any building or structure, or damage to any public or private property and damage to underground property. The insurance policy provided for the protection of the Contractor shall cover liability assumed under Section **GP-7.14**. The Maryland Aviation Administration shall be

furnished with certified evidence that said insurance issued in the name of the Contractor is in force and is in such form that the Maryland Aviation Administration may require.

- E. The certified evidence concerning the insurance shall be delivered to the MAA, Director, Capital Program Division, within ten (10) days after the date of recommended award of the Contract and shall be approved by the Director, Capital Program Division, before any work is done. No policies shall be canceled unless fifteen (15) days prior notice is given to the Director, Capital Program Division, and such minimum notice of cancellation shall be provided for in the policies.
- F. The requiring of any and all insurance as set forth in these Specifications or elsewhere shall be in addition to and not in any way in substitution for, all other protection provided under the Contract Documents.
- G. No acceptance and/or approval of any insurance by the Maryland Aviation Administration shall be construed as relieving or excusing the Contractor or the Surety on his/her bond from any liability or obligations imposed upon either or both of them by the provisions of the Contract Documents.

SP-3.03 Third Party Beneficiary Clause

It is specifically agreed between the parties executing the Contract that it is not intended by any of the provisions of any part of the Contract to create the public or any member thereof a third party beneficiary or to authorize anyone not a party to the Contract to maintain a suit for personal injuries or property damage pursuant to the terms or provisions of the Contract.

SP-3.04 Builder's Risk Insurance

Contractor shall at its own cost insure the work on an "all risk" basis and keep it insured at all times during the period of construction, until receipt of notice of final acceptance from the Administration. The amount of insurance shall be, at all times, at least equal to the amount paid on account of work and materials plus the value of work and materials furnished or delivered but not yet paid for by the Administration. The Administration shall be named as loss payee under the builder's risk policy.

SP-3.05 Insurance Requirements for Asbestos Removal

- A. For work at the project sites involving asbestos removal, the Contractor shall procure and pay for insurance specified herein issued by companies acceptable to the Administration and licensed and authorized to do business in the State of Maryland.
- B. The Contractor shall forward to the Administration at the time of execution of the Contract, a Certificate of Insurance issued by the Insurer(s), including special endorsements. The Contractor shall furnish policies satisfactory to the

Administration as to contents and carriers, and such insurance will contain the following provision:

1. Sixty (60) days prior notice to the Administration of cancellation.
 2. Inclusion of the Administration, the Engineer, and their directors, officers, representatives, agents, and employees as additional Insured in respect to work or operations in connection with the Contract.
 3. Endorsement providing that such insurance is primary insurance and no insurance of the Administration will be called in to contribute to a loss.
- C. If at any time the required insurance policies should be canceled, terminated, reduced in the limit of liability, or modified so that the insurance is not in full force and effect as required herein, the Administration may terminate this Contract for default or obtain insurance coverage equal to that required herein, the cost of which shall be charged to the Contractor and deducted from any monies due or that may become due the Contractor.
- D. Insurance similar to that required by the Contractor shall be provided by or on behalf of all subcontractors of any tier and other entities to cover their operation(s) performed under this Contract. The above provisions are to be included in all subcontracts.
- E. The Contractor shall not commence work under the Contract until evidence of all the insurance coverage required has been received, reviewed, and approved by the Maryland Aviation Administration.
- F. Insurance coverage: The coverage of insurance under such policy or policies shall be at policy limits not less than as specified herein.
1. Workers' Compensation and Employers' Liability: Providing statutory coverage in the State of Maryland, to include All States endorsement, and occupational disease or toxic exposure, and Employers' Liability (Coverage B), with a minimum limit of ONE MILLION DOLLARS (\$1,000,000.00).
 2. General Liability Insurance with a combined single limit of liability of ONE MILLION DOLLARS (\$1,000,000.00) per occurrence. The Contractor shall secure the following coverage endorsements:
 - a. Comprehensive General Liability Broad Form;
 - b. Contractual Liability;
 - c. Premises - Operations Liability;
 - d. Product and Completed Operations Liability;

- e. Broad Form Property Damage;
 - f. Fire Legal Liability;
 - g. Independent Contractors Liability; and
 - h. The Contractor shall secure coverage for its asbestos abatement operations under the Contract. In the alternative, the Contractor shall show evidence of the deletion of the asbestos/toxic exposure exclusion to the policy.
- G. The Contractor shall maintain all of the above coverages until such time as he/she receives notice from the Administration of the final acceptance of the project as defined within the Contract.

SP-3.06 Bankruptcy Notification

In the event the Contractor enters into proceedings related to bankruptcy, whether voluntary or involuntary, the Contractor agrees to furnish, by certified mail, written notification of the bankruptcy to the Procurement Officer responsible for administering the Contract. This notification shall be furnished within five days of the initiation of the proceedings related to bankruptcy filing. This notification shall include the date on which the bankruptcy petition was filed, the type of bankruptcy petition filed, and the identity of the court in which the bankruptcy petition was filed. This obligation remains in effect until after final payment has been issued.

SECTION 4

CONSTRUCTION REQUIREMENTS AND CONDITIONS

SP-4.01 Pre-Construction Conference

A Pre-Construction Conference will be scheduled with the Contractor to discuss his/her planning, proposed personnel, schedules, material sources, equipment, and other matters essential to the satisfactory performance of the work. All airport operations and security requirements will also be discussed.

SP-4.02 Notice to Proceed

The Notice to Proceed as defined in **GP-8.02** will be issued within one hundred and twenty (120) calendar days after the Notice of Recommended Award, subject to the conditions of **SP-8.00**.

SP-4.03 Plans and Specifications Furnished to Contractor

The Contractor will be supplied with five (5) copies of the Contract Documents by the MAA. If any changes are made to these documents, the MAA will provide the Contractor with five (5) copies of any revisions or additions to the Contract documents. The Contractor shall have available on the work-site, at all times during the prosecution of the work, one (1) updated copy of said Contract Documents. Additional complete copies of the Contract Documents are available at the price stated in the Notice to Contractors. The Contractor is responsible for obtaining the latest issue of all other documents referenced in the Contract Documents.

SP-4.04 Contractor's Staging Area

- A. An area of the Administration's property as shown on the Contract Drawings or to be designated at the Pre-Construction Conference will be available for use by the Contractor during the duration of the project as the staging area. The Contractor shall be responsible for security and maintenance of his/her staging area at all times. All costs incurred thereby shall be considered incidental to work under this Contract.
- B. It is intended that equipment and materials needed for the construction will be stored in the designated Contractor's staging area. A construction work area will be made available to the Contractor on a limited basis for the storage of equipment in the vicinity of the work area. Equipment and materials necessary at the work site(s) may be transported to those site(s) only as necessary to meet approved schedules. At the end of each working day, the Contractor's equipment shall be withdrawn to the designated area and placed in an orderly fashion.

- C. Staging areas and all areas used for storage of equipment or material shall be restored to their pre-existing original condition immediately upon completion of each phase or the project, as required by the Engineer. No additional compensation shall be provided for pavement repair, regrading, placement of topsoil, seeding and mulching in disturbed areas, or for any restoration activity required by the Owner.

SP-4.05 Access to Site

- A. No access to the construction site shall be through the terminal area except as approved by the Engineer. Specific access routes to the construction area will be subject to approval of the Engineer and will be discussed at the pre-bid conference. All persons entering the Airport property must have proper identification. Routing within the airfield area shall be subject to the approval of the Engineer.
- B. The approved haul routes shall be built and maintained by the Contractor. Where such routes cross underground utilities, the depth of the utility shall be determined by exploratory excavation, and suitable measures taken, such as the construction and maintenance of temporary fill to provide a minimum of cover over the utility.
- C. Upon completion of the Contract, any areas occupied by construction roads shall be properly graded, existing topsoil shall be replaced and the areas shall be seeded and mulched to return them to a condition at least equal to that which existed prior to their use by the Contractor. Sod may be required in such areas which receive backwash from aircraft.
- D. All Contractors who require access through any airfield post gates(s) or other areas will be issued key(s) by the MAA, Office of Airport Operations. The Contractor will be required to post a Five Hundred Dollars (\$500) deposit for each key. The deposit will be made with the MAA, Office of Business Administration, Division of Finance, Accounting Section. A receipt will be issued to the Contractor by the Accounting Section. Upon completion of the Contract, the Contractor shall return all keys to the MAA, Office of Airport Operations. After verifying that all keys have been returned, the MAA, Office of Airport Operations, will notify the Accounting Section to refund the Contractor's deposit.
- E. If the Contractor shall lose a key(s), the Five Hundred Dollars (\$500) deposit per key will be forfeited. The Contractor may request a replacement key at an additional key deposit of Five Hundred Dollars (\$500). Each replacement key will also be subject to forfeiture of the Five Hundred Dollars (\$500) deposit if lost by the Contractor.

SP-4.06 Federal Aviation Administration Facilities

The Contractor's special attention is directed to the Federal Aviation Administration (FAA) facilities (including power and control cables) as well as airfield lighting facilities located on the worksite. Any damage to these facilities by the Contractor's operations will be repaired or replaced by the FAA at the Contractor's expense. The Contractor shall notify the Engineer in writing at least thirty (30) days prior to beginning any work which will interfere with FAA navigational aids.

SP-4.07 High Structure Approval Procedure

The Contractor shall be responsible for obtaining FAA and MAA approval for any temporary structures, construction equipment and cranes which are not shown or included in the contract Safety and Phasing plans. If the Contractor wishes to place temporary structures, construction equipment and cranes at locations and/or heights which differ from the Safety and Phasing plans, the Contractor must submit a Notice of Proposed Construction or Alteration (FAA Form 7460-1) to the MAA Division of Planning for coordination and approval. The FAA requires approximately 90 calendar days to review Form 7460-1. Once the FAA has approved Form 7460-1, the MAA Division of Planning will issue an Airport Zoning Permit to the Contractor. The MAA review time is approximately 10 calendar days. No additional contract time or claim will be considered due to delays in obtaining FAA and MAA approval of contractor-requested temporary structures, construction equipment and cranes. The FAA and MAA review times indicated above are approximate. MAA makes no commitment to the Contractor that approval will be granted within the specified times.

SP-4.08 Sanitary Provisions

The Contractor shall provide and maintain at all times in a neat and sanitary condition such accommodations for the use of his/her employees as may be necessary to comply with the requirements and regulations of the Department of Health or of other bodies or tribunals having jurisdiction thereof. He/she shall commit no public nuisance. No public restrooms shall be used unless approved by the Engineer.

SP-4.09 Dust Control and Housekeeping

- A. The Contractor shall maintain the work during construction and until the work is accepted. This maintenance shall constitute continuous and effective work prosecuted day by day, with adequate equipment and forces so that the work is maintained in satisfactory condition at all times.
- B. The Contractor shall maintain all existing utilities in an operational manner or standard as required by the Engineer.

- C. The Contractor shall be responsible for the control of dust in his/her own construction zone, and along all haul routes. The Contractor shall be liable for any damage caused as a result of dust arising out of negligent control and maintenance. Housekeeping of the entire construction area should be done on a continuous basis.
- D. The Contractor shall be responsible for safeguarding his/her construction area against thunderstorms and high winds. The Contractor shall monitor weather reports daily. If severe weather is forecasted, the Contractor shall properly secure all construction material and equipment and ensure that the construction site is free of all loose debris which could be blown off/around by the wind. When severe weather is forecasted to develop after working hours, the Contractor shall inspect the construction site at the end of the day to insure that the site is secured for high winds. The Contractor shall be liable for any damages caused as a result of blown debris, negligent control and maintenance.
- E. All work shall be properly protected during construction including the shielding of soft or fragile materials, when necessary and/or upon Engineers request, the temporary plugging of open lines and conduits during construction. At completion of each construction area(s), the work area(s) shall be thoroughly cleaned and all tools, equipment, obstructions, or debris as a result of the Contractor's operation shall be removed from the premises.
- F. If the Contractor fails to properly remove materials dropped, tracked, deposited, spilled, or blown onto existing facilities, within twenty-four (24) hours, the removal will be performed by the Maryland Aviation Administration, and the direct cost thereof plus one hundred percent (100%) of said cost will be deducted from monies due, or to become due the Contractor.

SP-4.10 Plant/Source Inspection

- A. The Engineer or his/her authorized representative may inspect, at its source, any specified material or assembly to be used in the work. Manufacturing plants may be inspected from time to time for the purpose of determining compliance with specified manufacturing methods of materials to be used in the work and to obtain samples required for his/her acceptance of the material or assembly.
- B. Should the Engineer conduct plant/source inspections, the following conditions shall exist:
 - 1. The Engineer shall have the cooperation and assistance of the Contractor and the producer with whom he/she has contracted for materials.

2. The Engineer shall have full entry rights at all reasonable times to such parts of the plant or other facility that concern the manufacture or production of the materials being furnished.
 3. If required by the Engineer, the Contractor shall arrange for adequate office or working space that may be reasonably needed for conducting plant/source inspections. Office or working space should be conveniently located with respect to the plant/source.
- C. It is understood and agreed that the Owner shall have the right to retest any material which has been tested and approved at the source of supply after it has been delivered to the site. The Engineer shall have the right to reject any material which, when retested, does not meet the requirements of the Contract Documents.

SP-4.11 Layout of Work

The Contractor shall layout its work from MAA's established base lines and bench marks indicated on the drawings, and shall be responsible for all measurements in connection with the layout. Any inconsistencies shall be reported to the Engineer for resolution prior to commencing work. The Contractor shall furnish, at its own expense, all stakes, templates, platforms, equipment, tools, materials and labor required to layout any part of the work. The Contractor shall be responsible for executing the work to the lines and grades that may be established or indicated by the Engineer. The Contractor shall also be responsible for maintaining and preserving all stakes and other marks established by the Engineer or by the Contractor's forces until authorized to remove them. If such marks are destroyed by the Contractor through its negligence before their removal is authorized, the Engineer may replace them and deduct the expense of the replacement from any amounts due, or to become due to the Contractor.

SP-4.12 Existing Utilities

- A. The Contractor shall not begin or make any excavation without first notifying the Maryland Aviation Administration and each and every public service company which may have underground facilities in the area(s) of the proposed work at least seventy two (72) hours prior to the commencement of such work. In Baltimore and Anne Arundel Counties, the Contractor must notify the public service companies of work intentions by calling MISS UTILITY at 1-800-257-7777.
- B. The Contractor shall notify and receive approval from the Engineer in writing seven (7) days in advance of any utility shut down that will affect the normal operations at Baltimore/Washington International or Martin State Airports. Utility shut downs shall only be allowed at night and during hours determined by the Engineer (normally between 11:00 midnight to 5:00 am). The Contractor shall provide the Engineer with the type of utility and anticipated duration of shut down and specific area(s) that will be affected as a result of this work.

- C. The Contractor is to maintain service under this Contract on all the existing water lines, telephone lines, gas lines, electrical lines, etc. during the progress of the work.
- D. The Contractor shall be fully responsible for any, and all damages to underground and aboveground utilities and facilities resulting from his/her operation. No separate measurement or payment will be made to the Contractor for locating, working around or protecting utilities. All costs incurred thereby shall be considered incidental to work under this Contract.
- E. The Contractor shall have available on-call sufficient specialty Contractors, such as electrical, plumbing, etc., to repair any damage to existing facilities that might occur as a result of construction operations regardless of when the damage might occur.
- F. The Contractor shall utilize above ground fire hydrants for any activities requiring a water source in accordance with the local Authority Having Jurisdiction. Airfield underground hydrants shall not be used under any circumstance by the Contractor or his subcontractors, unless approved in advance in writing by the Office of the Fire Marshal/Fire Rescue Department.

SP-4.13 Temporary Utilities

- A. The Contractor shall provide all electricity and water required for any and all purposes at the Airport under this Contract. The procurement, installation of meters and any permits that shall be required for the performance of this work shall be considered the Contractor's responsibility and incidental to the work under this Contract. All sources of water and electricity shall be approved by the Engineer in writing prior to use by the Contractor. The Contractor shall be responsible for transporting the water from the approved source to the working area. The Contractor shall restore any damage resulting from his/her operations.
- B. Unless otherwise provided in the Contract, the amount of each utility service consumed shall be charged to or paid for by the Contractor at the prevailing rates charged to the MAA or, where the utility is produced by the MAA, at reasonable rates determined by the Procurement Officer. The Contractor shall carefully conserve any utilities furnished without charge.
- C. The Contractor, at its expense and in a workmanlike manner satisfactory to the Procurement Officer, shall install and maintain all necessary temporary connections and distribution lines, and all meters required to measure the amount of each utility used for the purpose of determining charges. The Contractor shall be responsible for bringing water or electricity from its source to the construction area. Before final acceptance of the work by the MAA, the Contractor shall remove, at his/her expense, all temporary connections, distribution lines, meters, and associated paraphernalia.

SP-4.14 Request for Information Procedures

This section specifies administrative and procedural requirements for handling and processing of Requests For Information (RFI) initiated by the Contractor seeking clarification of contract drawings and specifications. A sample RFI form is included under these Special Provisions, Section 10, **SP-10.01** and in the Technical Provisions.

- A. Submit a RFI as soon as an issue requiring clarification arises. Allow a minimum of seven (7) business days for a response from the Administration.
- B. Completely identify all work affected by the RFI, with references to all pertinent drawing numbers and specification paragraphs included.
- C. Clearly identify relevant field conditions, dimensions and as-built conditions on sketches attached to the RFI.
- D. If the RFI addresses a conflict in the Contract Documents, clearly describe all pertinent portions of the Contract Documents in conflict and provide all data necessary to enable the Administration to respond to the RFI.
- E. Allow each subcontractor or supplier involved in, or affected by the RFI, to review the request prior to submission to the Administration and include a suggested solution to the issue addressed in the RFI that has been coordinated between the affected subcontractors or suppliers.
- F. Incomplete RFI's will not be considered and will be returned to the Contractor.
- G. Statements or other indications by the Contractor of potential time or cost impacts on a submitted RFI shall not serve as written notification of a claim, as required by **GP-4.06**, Changes and **GP-5.14**, Claims. If, upon receipt of the Administration's response to a RFI, the Contractor believes it is entitled to an equitable adjustment, the Contractor must follow the procedures detailed in **GP-4.06**, Changes and **GP-5.14**, Claims.

SP-4.15 Supervision by the Engineer

The work is to be carried out under the supervision of the Engineer and to his/her entire satisfaction. The work and materials shall be strictly of the best quality of the kinds herein specified; and should any work or materials other than those specified or shown be introduced into the construction of the work, the Engineer, or authorized agent, shall have full power to reject them, and they shall be removed from the premises within twenty-four (24) hours by the Contractor after being notified to do so.

SP-4.16 Burning and Welding Permits

A burning and welding permit must be obtained by the Contractor from the Airport Fire and Rescue Department before burning, welding, or use of an open flame on airport property. The Contractor shall comply with all requirements of the permit at all times.

Permits will be issued between the hours of 9 am-11 am and 1 pm-3 pm Monday through Sunday. Permits will only be issued outside of these hours in an emergency situation. An emergency is defined as something that will disrupt airport operations and cannot wait to be fixed.

SP-4.17 Energized Equipment Work Permits

An energized equipment work permit must be obtained by the Contractor from the Office of Facilities Maintenance before working on any equipment which must remain in service and cannot be de-energized. The Contractor shall comply with all requirements of the permit at all times. Energized equipment includes, but not limited to, electrical and mechanical equipment.

SECTION 5 CONTROL OF THE WORK

SP-5.01 Archaeological and Historical Findings

- A. Unless otherwise specified in the Contract Documents, the Contractor is advised that the site of the work is not within any property, district, site, or does not contain any building, structure, or object listed in the current National Register of Historic Places published by the United States Department of the Interior.
- B. Should the Contractor encounter, during his/her operations, any building, part of a building, structure, or object which is incongruous with its surroundings, he/she shall immediately cease operations in that location and notify the Engineer. The Engineer will immediately investigate the Contractor's finding and will direct the Contractor either to resume his/her operations or to suspend operations as directed.
- C. Should the Engineer order suspension of the Contractor's operations in order to protect an archaeological or historical finding, or order the Contractor to perform extra work, such shall be covered by an appropriate contract modification (change order or supplemental agreement).

SP-5.02 Environmental Protection

- A. To prevent land, water and air pollution, delay of operations may be required until climate or wind conditions dissipate or inhibit the potential pollutant in a manner satisfactory to the Engineer. In the event of conflict between the requirements of this Contract and the requirements of pollution control laws, rules, or regulations of other federal, state, or local agencies, the more restrictive laws, rules, regulations shall apply.
- B. The Contractor shall comply with all Federal, State, and local laws and regulations controlling pollution of the environment. He/she shall take necessary precautions to prevent pollution of waterways, streams, lakes, ponds, and reservoirs with fuels, oils, bitumens, chemicals or other harmful materials and to prevent pollution of the atmosphere from particulate and gaseous matter. Such measures, as determined by the Engineer, may consist of construction of berms, drains, and sediment basins, or use of fiber mats, turbidity curtains, woven plastic filter cloths or other erosion and pollution control devices and/or methods.
- C. Environmental Protection Agency's National Pollutant Discharge Elimination System (NPDES) Permit for Construction Activity

On projects involving disturbance of five (5) acres or more, a Notice of Intent (NOI) to comply with the General Permit for Construction Activity, in accordance with the

Environmental Protection Agency's NPDES stormwater program, will be issued by the Maryland Department of the Environmental Water Management Administration (MDE/WMA) to the MAA. The NOI and General Permit authorize the discharge of stormwater, associated with the Clean Water Act, from the project site. The NOI and General Permit require strict compliance with the contract erosion and sediment control and stormwater management plans.

Upon receipt of the NOI, the Administration will transfer to the Contractor the responsibilities and requirements of the NOI and General Permit. The Contractor will be responsible for compliance under all terms of the NOI and General Permit. As the party directly responsible for the control of the permitted activities on the project site, the Contractor will assume full responsibility of the permitted activities by executing a Transfer of Authorization form within five (5) calendar days of receiving it and returning it to the Engineer. In addition, the Contractor will, in accordance with the NOI/General Permit requirements, conduct inspections of erosion and sediment controls and maintain records of these inspections, submitting a Notice of Termination form upon completion of the construction activity and final stabilization of the project site, and meet all other obligations described in the General Permit. Copies of any documentation required by the NOI and General Permit will be submitted to the Engineer at the completion of the project. A copy of the General Permit, Transfer of Authorization, and Notice of Termination forms are available for review at the Administration's Office of Planning and Engineering by contacting the Procurement Officer.

SP-5.03 Equal or Approved Equal

- A. When any article is specified by proprietary name, trade name, and/or name of the Manufacturer, with or without the addition of such expressions as "or equal" or "or approved equal", it is to be understood that the article named or the equal thereof is intended, subject to the approval of the Engineer as to the quality thereof; and it is distinctly understood:
1. That the Engineer is to use his/her own judgment in determining, from time to time, whether or not any article proposed to be substituted is the equal of any article so specified;
 2. That the decision of the Engineer on all such questions of equality shall be final; and
 3. That, in the event of any adverse decision by the Engineer, no claim of any sort shall be made or allowed against the Engineer, or the Maryland Aviation Administration because of such decision.
- B. All contractors are hereby instructed to use for the preparation of their bid the Products and the Manufacturers of the same type as specified in the Contract Documents. The offer of an equal but different product by the Contractor in lieu of

the specified product will raise the presumption that it is for the purpose of saving money. If, in such a case, the article is approved, the Maryland Aviation Administration shall be given credit in the amount of the difference between the net cost to the Contractor of the article submitted and the price at which he/she could have obtained the lowest price article specified. For convenience in checking the credit, if any, the Contractor shall submit these figures when the offer is made, and no article will be considered without such figures.

- C. The word "article," wherever used in this subsection entitled "Equal or Approved Equal," shall be taken to mean any article, material or thing.

SP-5.04 Request for Substitutions

- A. Requests for substitutions shall be made for any material or equipment which is to be utilized on the project which varies or deviates from the requirements of the Contract Documents. The intention of this section is to allow for the use of new and improved products passing specified tests after the completion of design. The Contractor is also referred to Special Provisions Section **SP-5.03**, Equal or Approved Equal.
- B. When requesting substitutions, the Contractor must complete and submit the "Substitution Request Form" in addition to the requirements set forth under this item. A sample "Substitution Request Form" is included in the Special Provisions, Section 10, **SP-10.02**, and in the Technical Provisions.
- C. Submit a minimum of six (6) copies, fully identified for a product or method being proposed for substitution, including related Specification Section and Drawing Number(s), and fully documented to show compliance with requirements for substitutions. The request for substitution submittal should include the following:
 - 1. Project data/drawings,
 - 2. Descriptions of methods,
 - 3. Samples where applicable,
 - 4. Contractor's detailed comparison of significant qualities between specified item and proposed substitution,
 - 5. Statement of effect on construction time and coordination with other affected work,
 - 6. Cost information or proposal, and
 - 7. Contractor's statement to the effect that proposed substitution will result in overall work equal to or better than work originally indicated.

- D. In making a formal request for substitution, the Contractor represents that:
1. He/she has investigated the proposed product and has determined that he/she is equivalent to or superior in all respects to that specified.
 2. He/she will provide the same warranties for substitution as for the product specified.
 3. He/she will coordinate the installation of an accepted substitution into the work, and will make such changes as may be required for the work to be complete in all respects.
 4. He/she waives claim for additional costs caused by the substitution that may subsequently become apparent.
 5. Cost data are complete and include related costs under the construction contract.
 6. Proposed product will not affect or delay the construction progress schedule.
 7. He/she will pay for changes to the design, including architectural or engineering design, detailing, and construction costs caused by the requested substitution.
- E. Document each request with supporting data substantiating compliance of proposed substitution with Contract Documents, including:
1. The Manufacturer's name and address, product, trade name, model or catalog number, performance and test data, and reference standards.
 2. Itemized point by point comparison of proposed substitution with specified product, listing variations in quality, performance, and other pertinent characteristics.
 3. Changes required in other work.
 4. Availability of maintenance service and a source of replacement parts, as applicable.
 5. Certified test data to show compliance with performance characteristics specifies.
 6. Samples, when applicable or requested.

7. Complete cost analysis including a breakdown of materials, equipment and labor costs with separate breakdowns labor burdens, overhead and profit.
 8. Other information as necessary to assist in the Engineer's evaluation.
 9. All such associated costs for confirmation or acceptance testing of new materials not outlined in the specifications shall be borne by the Contractor at no cost to the MAA.
 10. Where a requested deviation or waiver on a particular aspect of the work has a relation to, or affects other aspects of the work, those other aspects of the work shall be clearly identified and referenced. If the requested deviation or waiver necessitates a deviation or waiver on the other aspects of the project, requests for all such deviations and waivers must be submitted concurrently.
- F. Requests will only be considered in documented cases of product unavailability or other cases beyond the control of the Contractor. Such requests must be submitted to allow adequate time for review of associated submittals in accordance with the schedule requirements. Allow a minimum of forty five (45) calendar days for review of requested substitutions. All requests must contain a complete cost comparison.
- G. Substitutions not submitted in strict accordance with this provision will not be considered for acceptance when:
1. They are indicated or implied on shop drawings or product data submittals without a formal request from the Contractor.
 2. Acceptance will require substantial revision of the Contract Documents.
 3. Submittal for substitution request does not include point by point comparison of proposed substitution with the specified product.
 4. In the judgment of the Engineer, the submittal does not include adequate information necessary for a complete evaluation.
 5. If requested directly by a subcontractor or supplier.
- H. The Contractor shall be responsible for obtaining any and all required permits and licenses resulting from substitutions approved by the Engineer.
- I. All costs associated with confirmation or acceptance testing of new materials not outlined in the specifications shall be borne by the Contractor at no cost to the Owner.
- J. Substitute products shall not be ordered or installed without written acceptance of the Engineer.

- K. The Engineer will determine acceptability of proposed substitutions and reserves the right to reject any and all materials or methods not in accordance with the Contract Documents.

SP-5.05 Disposal of Excess Material

- A. Material to be removed or demolished which shall not be requested by the State shall become the property of the Contractor and shall be removed from the site and disposed of at his/her cost and expense.
- B. It is the Contractor's responsibility to transport and dispose of demolished materials and refuse in licensed disposal areas off site at his expense. The Contractor shall be responsible for obtaining all permits and licenses required by authorities having jurisdiction and shall transport materials in accordance with all Federal, State and local ordinances, laws and regulations in effect.

SP-5.06 Authority of the Procurement Officer

- A. Contractor's Staff

The Contractor shall submit in writing the names and qualifications of all individuals assigned to the Contract [including principals of the Company, Project Manager and superintendent(s)] for the approval of the Procurement Officer. In the event the Procurement Officer does not approve of an individual offered by the Contractor, the Contractor shall offer a suitable substitute. At any time during the course of work, if, in the judgment of the Procurement Officer, any individual is deemed unacceptable, upon written notification from the Procurement Officer, the Contractor shall promptly offer a replacement for the Procurement Officer's approval. The Contractor will be responsible for any cost arising from the action of the Procurement Officer relative to **SP-5.06A**.

SP-5.07 Hazardous Materials

- A. As used herein, the term " Hazardous Material" means:
1. any "hazardous waste" as defined by the Resource Conservation and Recovery Act of 1976, as amended from time to time, and regulations promulgated thereunder;
 2. any "hazardous substance" as defined by the Comprehensive Environmental Response, Compensation and Liability Act of 1980 as amended from time to time, and regulations promulgated thereunder;
 3. any oil, petroleum products, and their by-products; and

4. any substance which is or becomes regulated by any federal, state or local governmental authority.
- B. All Contractors shall refer to the definition of hazardous materials and regulations for handling and disposing hazardous wastes in 40 CFR 261 Subpart D and Resource Conservation and Recovery Act, 42 USCA 6903 (3) and 6924, COMAR 26.13.01.03, COMAR 26.13.05 and 49CFR 172. Work involving the disturbance of asbestos containing materials shall comply with the requirements of 40 CFR 61, Subparts A and M and 29 CFR 1926.1101.
- C. The Contractor shall bring to the attention of the Engineer any material suspected of being hazardous that he/she encounters during execution of the work. A determination will be made by the Engineer as to whether the tests are necessary to determine if the material is hazardous. If the Engineer directs the Contractor to perform tests, and/or if the material is found hazardous and additional protective measures are needed, a change order may be required, subject to applicable provisions of the Contract.
- D. If required, a hazardous material handling plan may be necessary. The plan shall contain the following:
1. number, type, and experience of employees to be used for the work;
 2. description of how applicable safety and health regulations and standards are to be met;
 3. type of protective equipment and work procedures to be used;
 4. emergency procedures for accidental spills or exposures;
 5. procedures for disposing of or storing the toxic/hazardous materials;
 6. identification of possible hazards, problems, and proposed control mechanisms;
 7. protection of public or others not related to the operation;
 8. interfacing and control of subcontractors, if any;
 9. identification of any required analyses, test demonstrations, and validation requirements; and
 10. method of certification for compliance.
- E. Any hazardous material shall be disposed of in a manner that complies with all federal, state and local laws or regulations applicable to any such hazardous

materials. If hazardous materials are disposed of off-site, submit copies of permits from applicable Federal, State or municipal authorities and necessary certificates that the material has been disposed of as per applicable regulations.

- F. The Contractor hereby agrees that he/she shall be fully liable for all costs and expenses related to the disposal of hazardous material that have been identified in this Contract. The Contractor shall defend, indemnify and hold harmless the Administration and its Agents, from and against any claims, demands, penalties, fines, liabilities, settlements, damages, costs, or expenses (including, without limitation, attorney and consultant fees, court cost and litigation expenses) of whatever kind or nature, known or unknown, contingent or otherwise, arising out of or in any way related to:
1. the presence, disposal, release, or threatened release of any such hazardous material which is on, from or affecting the soil, water, vegetation, buildings, personal property, persons, animals, or otherwise;
 2. any personal injury (including wrongful death) or property damage (real or personal) arising out of or related to such hazardous material;
 3. any lawsuit brought or threatened, settlement reached or government order relating to such hazardous material, and/or
 4. any violation of any laws applicable thereto.

SP-5.08 Environmental Permits

Depending on the impacts of a project, the environmental permits/approvals may include, but not be limited to, those listed below.

1. U.S. Army Corps of Engineers: wetlands impacts; dredging or filling waters of the U.S.
2. Federal Emergency Management Administration: floodplain impacts.
3. U.S. Coast Guard Permit: changes to navigable waterways.
4. Maryland Department of Environment: sediment/erosion control; stormwater management; water quality; wetland impacts; floodplain impacts; waterway construction; water appropriation and use; waste water discharge (surface, groundwater); water or sewer connection; monitoring well construction.
5. Chesapeake Bay Critical Area Commission: construction within boundaries of the Critical Area.

6. Department of Natural Resources, Forest Conservation Program: tree cutting and conservation.

SP-5.09 HVACR Licensing Requirements

- A. The heating, ventilation, air-conditioning or refrigeration (HVACR) law requires all individuals who provide or assist in providing heating, ventilation, air-conditioning and/or refrigeration services to be licensed prior to engaging in installation or servicing of such systems.
- B. Contractors bidding on any contract involving HVACR systems must be a current Maryland-licensed HVACR Master or Master Restricted Contractor who is qualified in the areas of work specified in the Contract Documents.
- C. By submitting a bid, the successful Contractor agrees to employ only individuals who hold valid licenses issued by the State HVACR Board to provide, or assist in providing, HVACR services as specified in the Contract Documents during the term of the Contract.
- D. If the successful Contractor subcontracts any or all of the HVACR work specified in the Contract Documents, the subcontractor(s) must possess the appropriate license required by the State HVACR Board.
- E. The HVACR subcontractor(s) must agree to consistently use only individuals who hold the appropriate licenses issued by the State HVACR Board to provide or assist in providing heating, ventilation, air-conditioning and/or refrigeration services as specified in the Contract Documents during the life of the Contract.
- F. For each individual proposed to be engaged in the installation and/or servicing of HVACR systems, the Contractor and/or the subcontractor(s) must submit a copy of a valid HVACR Master or Master Restricted license issued by the State of Maryland to the Engineer a minimum of fourteen (14) days prior to starting HVACR work. For the systems installed or serviced by unlicensed individuals the Contractor agrees to remove and re-install and/or re-service the system by licensed individuals at no cost to MAA.

SECTION 6 SECURITY AND SAFETY

SP-6.01 BWI Airport Security

A. Airport Security

1. All Contractor employees shall comply with all BWI Airport security regulations, as mandated by the Federal Aviation Administration (FAA). The Airport shall take immediate and aggressive action to ensure compliance with Airport Security, the BWI Airport Security Program, and United States Public Law 106-528, "The Airport Security Improvement Act of 2000."
2. Security is to be maintained at all times. If security is breached or penetrated in any manner or form at any time during this contract, the Contractor is required to immediately restore "security" regardless of the circumstances. The Contractor shall be responsible for maintaining the integrity of the Controlled Access Security System for the duration of this contract.

B. BWI Airport Access Badges

1. All Contractor personnel who, in the performance of their duties, must have unescorted access to the Security Identification Display Area (SIDA) of the Airport shall first obtain a valid BWI Airport-issued Access (Identification) Badge from the Administration. Prior to badge issuance, the individual requesting an unrestricted badge must first undergo a Criminal History Record Check via FINGERPRINTING as mandated by United States Public Law 106-528. While awaiting the results of the fingerprint check, an applicant for an Identification Badge may be issued 45 days of provisional access to the SIDA if a 10 year Employment Investigation Check with no lapse in employment is submitted and there is proof that fingerprints have been submitted to the FBI for a Criminal History Record Check.

Upon return of the result of the Criminal History Record Check to the Security Center, if there are no disqualifying crimes, the provisional badge will be rescinded and an unrestricted badge will be issued. If there are disqualifying crimes, the provisional badge will be rescinded and an unrestricted badge will not be issued. If a provisional badge has expired before the results the Criminal History Record Check is returned to the Airport Security Center, the provisional badge will be rescinded and the applicant must be escorted by an employee with an unrestricted badge

while in the SIDA. The failure of an employee/employer to return a provisional access badge to the Airport Security Center upon the end of the 45 days provisional access period shall be considered a violation of Public Law 106-528, FAR Part 107, and the Airport Security Program.

If the work to be completed by a particular subcontractor is short-term, and appropriately badged personnel are available, said employees may be escorted. The escort(s) must stay within immediate physical proximity of the escorted employee(s) at all times (normal speaking voice range).

Sub-contractor having a need to be badged must be processed as follows: The General/Primary contractor must submit to the Airport Security Center a sponsorship letter, which includes contract/project title, function, access requirements, duration, point of contact and hours of operation. If the General/Primary contractor delegates signatory authority to the subcontractor, this must also be stated in the letter, and the individual identified.

2. The Administration office or section with the primary duty of managing the subject contract (known as Airport Operator) shall be responsible for performing the Criminal History Record Check via fingerprinting. A contractor's manager or supervisor shall be designated as the "authorizer" and shall be responsible for the Employment Investigation Check. This individual shall sign all access badge applications. The Contractor is required to send a letter to the Administration indicating the name of the manager or supervisor responsible for the Employment Investigation Check. It is required that the designated "authorizer" also sign this letter so that his/her signature is on file in the Airport Security Center.
3. Contractor personnel shall not be permitted to begin work on the job site until issued an access badge. Badges must be displayed at all times on the outer garment above the waist while the employee is in the SIDA.
4. The Administration reserves the right to confiscate and suspend the access badge of any employee allegedly involved in any felonious act or security violation at the Airport; and, upon a guilty, nolo contendere, or probation before judgment disposition of the charge, to revoke the access badge.
5. The Contractor is hereby warned that all persons not properly identified by an Airport-issued access badge may be challenged, and if positive identification or association cannot be made, the appropriate corrective action shall be taken.
6. At the completion of the contract or in the event any employees are terminated, the Contractor must return all access badges and airfield

vehicle permits to the Procurement Officer for computer deprogramming as soon as possible.

7. The Contractor is also responsible for the cost of replacement badges, if lost.

C. Access Badge Procedures

1. All BWI Airport access badge applicants and those requesting the authority to authorize others to have unescorted access privileges to the SIDA must thoroughly complete a BWI Airport Access Badge Application and Attachments, must undergo a Criminal History Record Check (FINGERPRINTING), and undergo SIDA training.
2. The Contractor shall verify the identity of the access badge applicant through the presentation of two forms of identification, one (1) with the individual's photograph.
3. The access badge applicant must satisfactorily undergo a review, by the present employer, covering the past 10 years of employment history, and verification of the five (5) years preceding the date the access investigation is initiated. Information on the most recent five (5) years must be verified in writing, by documentation, by telephone, or in person.

A contractor may elect to utilize fingerprinting results instead of the 10 years Employment Investigation Check however, an applicant will not be issued a 45 days provisional badge or an unrestricted badge until successful completion of a Criminal History Record Check (FINGERPRINTING).

If verification is made by telephone, the information shall be obtained from a person in a position to speak on behalf of the company, and who has access to those records used to verify the information being requested.

4. The BWI Airport Access Badge Application along with the Attachments shall be submitted to the Administration prior to access badge issuance. The applicant's "access investigation" information shall be maintained by the employing agency/company in written form until 180 days after the termination of the individual's authority for unescorted access. The "access investigation" records must include: the application, the employment verification information obtained by the employer, the names of those from whom the employment verification information was obtained, the date the contact was made, and any other information as required by the Assistant Administrator for Civil Aviation Security.

D. Airfield Vehicle Ramp Permit/Temporary Airfield Vehicle Registration

1. The Contractor shall secure from the Airport Operations Center an airfield vehicle ramp permit or temporary airfield vehicle registration to facilitate unescorted vehicular movement around the airfield areas, where necessary, to fulfill the obligations of this contract.
2. Contractor shall abide by all driving rules and regulations at BWI Airport as determined and approved by the Administration.

E. Airport Perimeter Access Control

1. Dependent on the contract's scope of work, perimeter access control may be an issue. All perimeter fence gates (manual and automatic) must be secured or manned (guarded) at all times. Any access portal (gates/doors) found to be unsecured, or any entry by an unauthorized person(s) and/or vehicle(s) shall subject the Contractor to a FAA-imposed penalty or fine of up to \$10,000 per occurrence, and/or suspension/revocation of the violator's BWI Airport access badge.
2. During certain circumstances, the Contractor may require the use of a guard. In the event this option is exercised, the procedures shall be submitted in writing to, and approved by, the Security Manager.

In addition, these post and guards must be approved and coordinated, in advance with the Airport Security Center. All guard personnel shall possess a means of communication, which will facilitate the dispatching of law enforcement support in the event of an incident. Depending on the access gate location, an Access/Stoplist must be utilized (provided by the Airport Security Center).

3. Gate attendants (guards) may be Contractor employees, or others hired by the Contractor for this sole purpose. It shall be the responsibility of the Contractor to ensure all required security training is completed and understood. All gate attendants must have been issued a BWI Airport access badge prior to manning any access portal. The access badge must be displayed at all times while in the SIDA. Specific FAA-mandated security rules and regulations, as well as BWI Airport Security Program requirements will be provided by the Airport Security Center.

F. Vehicular Movement on the Air Operations Area (AOA)

1. Control of vehicular traffic on the AOA is regulated by Code of Maryland Regulation (COMAR) 11.03.01.04. Detailed regulations are available at the Airport Security Center (Study Guide -- COMAR 11.03.01.04). As part of

the Airfield Safety Training requirements, and prior to taking the written test, this Study Guide shall be provided to all appropriate personnel.

2. All vehicles shall be inspected and approved for operating on the AOA by the Administration's Division of Maintenance, prior to airfield vehicle registration. Vehicles satisfactorily completing the safety inspection shall be registered by the Airport Operations Center.

G. Penalties

In the event that the Administration shall be subject to any fine or penalty by reason of any violation at BWI Airport of any governmental (including FAA) rules, regulations, or standards as they now exist or may hereafter be promulgated or enacted, the Administration may conduct an investigation and make a determination as to the identity of the party responsible for the violation. If it is determined by the Administration that the Contractor is responsible for all or part of the fine or penalty, the Contractor shall pay said amount of the fine or penalty. The Administration and the Contractor shall each have the right to contest the validity or amount of such fine or penalty before the governmental entity seeking to impose such fine or penalty. In addition, the Administration and the Contractor are each entitled to a hearing regarding the Administration's determination pursuant to the Laws of Maryland, Transportation Article, Section 5-209 and 5-210, the Maryland Administrative Procedure Act and COMAR Title 11, Subtitle 01, Chapter 14 entitled "Procedure for Hearings in Contested Cases."

SP-6.02 Martin State Airport Security

Security regulations at Martin State Airport shall require the Contractor to comply with all rules and regulations as determined and approved by the Engineer. Security is to be maintained at all times. The Contractor shall maintain and enforce control of the operation of its vehicles and those belonging to its employees, subcontractors or tradesmen on Airport property. No vehicles of personnel will be permitted within the AOA except those directly involved in performance of the work. All other vehicles and equipment shall be parked in designated areas. No vehicles or personnel will be permitted to enter or cross runways, taxiways, or aprons without first obtaining permission from ATCT. Vehicles and/or personnel within AOA's shall immediately vacate these areas when directed to do so and shall stay clear of affected areas until permission is granted for re-entry. The Contractor is hereby warned that all persons not properly identified by approved construction employee ID badge may be challenged, and if positive identification or association cannot be made, the appropriate fine will be levied.

SP-6.03 Safety Requirements During Construction

- A. For all projects within the airfield, the Contractor shall acquaint his/her supervisors and employees with the Airport activity and operations that are inherent to

Baltimore/Washington International and/or Martin State Airports and shall conduct his/her construction activities to conform to all routine and emergency air traffic requirements and guidelines for safety specified herein.

- B. The Contractor shall not allow employees, subcontractors, suppliers, or any other unauthorized person to enter or remain in any airport area which would be hazardous to persons or to aircraft operations.
- C. The Contractor shall be aware of the following types of safety problems and/or hazards:
 - 1. Trenches, holes, or excavations on or adjacent to any open runway or in safety areas.
 - 2. Unmarked/unlighted holes or excavation in any apron, open taxiway, open taxilane, or related safety area.
 - 3. Mounds or piles of earth, construction materials, temporary structures, or other objects in vicinity of the open runway, taxiways, taxilanes, or in a related safety, approach, or departure area.
 - 4. Vehicles, equipment, excavations, stockpiles, or other materials which could degrade or otherwise interfere with electronic signals from radios or NAVAIDs.
 - 5. Pavement drop-offs or pavement-turf lips (either permanent or temporary) which could cause, if crossed at normal operating speeds, damage to aircraft that normally use the Airport. The FAA AC 150-5370-2C Paragraph 7.C states "Runway surfacing projects resulting in excessive lips greater than one inch for runways and three inches for edges between old and new surfaces at runway edges and ends."
 - 6. Unmarked utility, NAVAID weather service, runway lighting, or other power or signal cables that could be damaged during construction.
 - 7. Objects (whether or not marked or flagged) or activities anywhere on or in the vicinity of Airport which could be distracting, confusing, or alarming to pilots during aircraft operations.
 - 8. Unflagged/unlighted low visibility items (such as tall cranes, drills, and the like) anywhere in the vicinity of active runways, or in any approach or departure area.
 - 9. Misleading or malfunctioning obstruction lights or unlighted/unmarked obstructions in approach to any open runway.

10. Inadequate approach/departure surfaces (These surfaces are needed to assure adequate landing/takeoff clearance over obstructions or work or storage areas).
 11. Inadequate, confusing, or misleading (to user pilots) marking/lighting of runways, taxiways or taxilanes (including displaced or relocated threshold).
 12. Water, snow, dirt, debris, or other transient accumulation which temporarily obscures pavement marking or pavement edges, or derogates visibility of runway/taxiway marking or lighting, or of construction and maintenance areas.
 13. Inadequate or improper methods of marking, barricading, and lighting of temporarily closed portions of airport operations area.
 14. Trash or other materials with FOD potential, whether on runways, taxiways, aprons, or in related safety areas.
 15. Inadequate barricading or other marking to separate construction or maintenance areas from open aircraft operating areas.
 16. Failure to control vehicle and human access to, and nonessential non-aeronautical activities in, active aircraft operating areas.
 17. Failure to maintain radio communication between construction/maintenance vehicles and ATCT.
 18. Construction/maintenance activities or materials which could hamper the response of aircraft rescue and firefighting equipment from reaching all aircraft or any parts of the runway/taxiway system, to runway approach and departure areas, and to aircraft parking locations.
 19. Bird attractants such as edibles (food scraps, etc.) or other miscellaneous garbage, other trash, or ponded water on Airport.
- D. 1. The Contractor is totally responsible for safety and health on the project. The Contractor shall conduct activities so as not to violate any safety requirements in applicable Federal, state, and local regulations or the standards contained herein. The Contractor shall inspect all construction and storage areas as often as necessary to be aware of conditions, and promptly take all steps necessary to prevent/remedy any unsafe or potentially unsafe conditions or activities discovered.

2. If the Engineer becomes aware of any conditions which pose a serious or imminent danger to the health or safety of the public or Administration personnel, the Engineer shall notify the Contractor orally, with written confirmation, and request immediate initiation of corrective action. This notice, when delivered to the Contractor or the Contractor's representative at the work site, shall be deemed sufficient notice of the noncompliance and that corrective action is required.
 3. After receiving the notice, the Contractor shall immediately take corrective action. If the Contractor fails or refuses to promptly take corrective action, the Procurement Officer may issue an order stopping all or part of the work until satisfactory corrective action has been taken.
 4. The Contractor shall not be entitled to any equitable adjustment of the Contract price or extension of time of the performance schedule on any stop work order issued under this clause. The Contractor shall insert this clause, including this paragraph, with appropriate changes in the designation of the parties, in all subcontracts. At no time shall the Contractor be relieved of the responsibility to be aware and correct any unsafe conditions.
- E. Before actual commencement of construction activity, the Contractor shall, through the Airport Management, give notice, using the NOTAM system, of proposed time and date of commencement of construction as well as the length and duration of the work in such areas. Upon completion of work and return of all such areas to standard conditions the Contractor shall, through the Airport Management, give notice, using the NOTAM system, of completion of construction.
- F. All Contractor's vehicles that are authorized to operate on the Airport outside of the designated construction area limits or haul routes as specified and in the active AOA shall display in full view above the vehicle a 3' x 3' or larger, orange and white checkerboard flag, each checkerboard color being square. Any vehicle operating in the active AOA during the hours of darkness shall be equipped with a flashing amber (yellow) dome-type light, mounted on top of the vehicle and of such intensity to conform to local codes for maintenance and emergency vehicles.
- G. Vehicles making only occasional visits to the job site are exempt from the identification requirements contained in Paragraph F. provided that they are escorted into, through, and out of the Airport secured area by a properly identified vehicle.
- H. Radio communications are required between the Contractor's representative and the ATCT. Radio contact is required at all times while the Contractor has personnel and equipment on the project site and while they are in an active AOA of the Airport. Radios shall be furnished by the Contractor and shall be capable of transmitting and receiving at a ground frequency of 121.9 MHZ for BWI Airport and

121.8 MHZ for Martin State Airport. Sufficient radios shall be on site and operating at all times so that instructions or communications may be dispatched to all crews and/or equipment working in an active AOA within one minute after receipt from the ATCT.

- I. Debris, waste and loose material (including dust and dirt) capable of causing damage to aircraft landing gear or propellers or being ingested in jet engines shall not be allowed on active aircraft movement areas or adjacent grassed areas. Materials observed to be within these areas shall be removed immediately and/or continuously by the Contractor during construction.
- J. The Contractor shall furnish, at his/her own expense, flagmen as necessary to control his/her traffic in accordance with these specifications unless otherwise directed by the Engineer, in which case the direction of the Engineer shall be followed.
- K. All Contractor's vehicles that are required to cross active runways, ramp areas, taxiways and aprons shall do so under the direct control of a competent flagman who is in direct radio contact with ATCT. All aircraft traffic on runways, ramp areas, taxiways and aprons shall have priority over Contractor's traffic. Radios shall be supplied by the Contractor and shall be capable of transmitting and receiving at a frequency of 121.9 MHZ for BWI Airport and 121.8 MHZ for Martin State Airport.
- L. Where project access requires travel on or across runways, ramp areas, taxiways, or aircraft aprons, all personnel shall keep such surfaces clear of debris. At no time shall the Contractor's vehicles or personnel be allowed to enter or cross active runways or clear zones without proper authorization obtained through ground control.
- M. Open flame, welding or torch cutting operations are prohibited unless adequate fire and safety precautions have been taken and the procedure previously approved by the Engineer.
- N. Equipment and stockpiled material shall be constrained in a manner to prevent movement resulting from aircraft jet blast or wind conditions.
- O. The Contractor shall provide timber or bucket type construction barricades with flashing yellow lights as shown on the drawings or directed by the Engineer to delineate the work areas when these areas are closed to airport traffic. Open trenches, excavations and stockpiled material located in the AOA shall be prominently marked with aviation orange flags and lighted by approved light units during hours of restricted visibility and darkness.
- P. All materials and equipment when not in use shall be placed in approved areas where they will not constitute a hazard to aircraft operations and not penetrate

clearance surfaces defined in Federal Aviation Regulation, Part 77 (**14 CFR, Part 77**).

- Q. The Contractor shall adhere to the requirements of Advisory Circular **150/5370-2**, "Operational Safety on Airports During Construction," current edition. Where **Part 77** and Advisory Circular **150/5370-2C** are in conflict, the most restrictive requirement shall be met.
- R. Maximum equipment height shall not exceed twenty (20) feet unless prior approval is obtained from the Engineer.
- S. Debris, waste and loose material (including dust and dirt) capable of causing damage to aircraft landing gear, propellers or being ingested in jet engines shall not be allowed on active aircraft movement areas or adjacent grassed areas. Materials observed to be within these areas shall be removed immediately and/or continuously by the Contractor during construction.
- T. Upon completion of any stage/phase of the work the Engineer will arrange a physical inspection with Airport operations personnel prior to opening for aircraft use any runway, taxiway, ramp area or airport roadway that has been closed for work, on or adjacent thereto, that has been used for a crossing point or haul route by the Contractor.
- U. Entrance to the airfield is subject to strict security regulations. All personnel entering the airfield must obtain and display security identification badges and all vehicles must have and display special permits issued by the Maryland Aviation Administration. The cost of these security items is fully refundable upon their return. The Contractor shall be responsible for assuring that all their employees who have unescorted access to the airfield, have background checks, including at a minimum, references and prior employment histories to the extent necessary to verify representations made by the employee relating to employment in the preceding five (5) years.
- V. The smoking or carrying of lighted tobacco, or other products is strictly prohibited on the airside of the airport. Failure to comply may result in fines and/or suspension of individual security badges. If the Engineer becomes aware of any conditions which pose a serious or imminent danger to the health or safety of the public or Administration personnel, the Engineer shall notify the Contractor orally, with written confirmation, and request immediate initiation of corrective action. This notice, when delivered to the Contractor or the Contractor's representative at the work site, shall be deemed sufficient notice of the noncompliance and that corrective action is required.

SP-6.04 Site Specific Safety Plan

- A. The Contractor shall be required to develop and submit a detailed Site Specific Safety Plan (“SSSP”) encompassing all work to be performed under the Contract on Administration property by his/her own forces and by his/her subcontractor forces. The SSSP shall be submitted during the Mobilization period specified elsewhere in the Contract.
- B. The Administration will issue a “Construction Notice to Proceed” (CNTP) for the project only if the Administration approves the Contractor’s SSSP. If issuance of the CNTP is delayed beyond the Mobilization period due to late or nonconforming SSSP submissions, the Contractor’s Performance Time specified elsewhere in the Contract shall be decreased by the number of days of delay in issuance of the CNTP.
- C. The Site Specific Safety Plan shall include, but not be limited to, the following:
 - 1. The Contractor’s corporate health and safety policies, procedures and documentation. The Contractor’s organizational responsibility for safety shall be detailed.
 - 2. Job Hazard Analysis (“JHA”) for each item of work to be performed under the Contract.
 - 3. Material Safety Data Sheet (“MSDS”) for each material utilized in performance of the work under the Contract.
 - 4. Confined Space Entry Program (if applicable)
 - 5. Lock-out / Tag-out procedures for existing utilities (if applicable)
 - 6. Support of Excavation Plans and Structure Shoring Plans (if applicable)
 - 7. The scope of indoctrination for new employees, procedures for weekly safety meetings, and the scope and frequency of project site inspections.
 - 8. The availability of, and enforcement of, procedures for the use of protective devices such as head protection, eye protection, hearing protection, clothing and footwear, respirators, safety belts and lanyards, wet weather gear, fire resistant blankets and/or barriers, and any other devices used for the protection of the individual employee’s health and safety.
- D. The Site Specific Safety Plan shall be in full compliance with the latest editions of the following:

1. OSHA General Industry and Health Standards (29 CFR 1910)
 2. OSHA Standards for the Construction Industry (29 CFR 1926)
 3. FAA Advisory Circular for Operational Safety on Airports During Construction (150/5370-2F)
 4. Maryland Occupational Safety and Health (MOSH)
- E. The Contractor shall be required to provide a Safety Officer to ensure full implementation of the approved Site Specific Safety Plan and applicable Federal and State safety standards throughout the duration of the Contract. The Safety Officer shall be a Certified Safety Professional (“CSP”), or equivalent, as approved by the Administration.
1. For Contracts in an amount of less than five million dollars (\$5,000,000), the Safety Officer shall be required to be on-site on a weekly basis at a minimum. The Safety Officer shall attend preparatory meetings in advance of the start of each new item of work to review the applicable JHA and other relevant safety requirements with the construction personnel. The Safety Officer shall also perform inspections of the work site for compliance with the approved SSSP and applicable Federal and State safety standards and provide a written report of his/her findings to the Engineer, including any corrective actions implemented.
 2. In addition to the above, for Contracts in an amount of five million dollars (\$5,000,000) or above, the Safety Officer shall be required to be on-site on a full-time basis throughout the duration of the Contract and have no other responsibilities than those required by this Special Provision.
- F. The Contractor shall assume full responsibility for compliance with all applicable regulations pertaining to the health and safety of personnel during the execution of the work, and shall hold the Administration and its agents harmless for any action on the Contractor's part, or that of the Contractor's employees or subcontractors that result in illness, injury or death.
- G. The Contractor shall immediately notify the Engineer upon encountering hazardous materials. As used herein, the term “hazardous materials” has the same definition as provided in **SP-5.07 - Hazardous Materials**. All work, including contact with and handling of hazardous materials, the disturbance and dismantling of structures containing hazardous materials, and/or the disposal of hazardous materials, shall comply with the applicable requirements of **SP-5.07**. Work involving lead shall comply with the requirements of **SP-6.06, Occupational Exposure to Lead in Construction Work**, of these provisions. Work requiring entry into confined spaces shall comply with the applicable requirement of **SP-6.07, Safety Hazards in Confined Spaces**, of these provisions. All work shall comply with applicable Federal and State safety and health requirements. Where there is a conflict between applicable regulations, the most stringent shall apply.

- H. In the event of an accident, injury or other medical emergency, the Safety Officer shall immediately notify the Engineer and begin a detailed incident investigation.
1. The Safety Officer shall provide a report to the Engineer documenting the all relevant facts pertaining to the accident, injury or other medical emergency. The Safety Officer shall also provide proposed corrective actions that the Contractor will immediately implement to avoid any reoccurrence of the accident, injury or other medical emergency.
 2. A copy of each accident report that the Contractor or subcontractors submit to their insurance carriers shall be forwarded to the Engineer as soon as possible, but in no event later than seven (7) days after the day the accident occurred.
 3. A copy of the Monthly Injury/Illness Report for the Contractor and each Subcontractor of every tier shall be forwarded to the Engineer as soon as possible, but in no event later than seven (7) days after the end of each month. A copy of the standard report form is included under Special Provision Section 10, *Form SP-6.04*.
 4. The Engineer may withhold processing of the Contractor's progress payment for failure to submit any required reports within the time period specified in this Special Provision.
- I. In the event that the Engineer becomes aware of any noncompliance with the approved Site Specific Safety Plan, applicable Federal or State safety standards, or any other unsafe or unhealthy conditions, the Engineer will immediately inform the Safety Officer and issue a Safety Deficiency Notice.
1. Once the Contractor is notified by the Engineer of any unsafe or unhealthy condition and the corrective action(s) to be taken, the Contractor shall immediately, if so directed, or within 48 hours after receipt of the Safety Deficiency Notice, correct the unsafe or unhealthy condition.
 2. If the Engineer becomes aware of any conditions which pose a serious or imminent danger to the health or safety of the public, Administration personnel and their agents, or the Contractor's personnel, the Engineer shall notify the Contractor orally, with written confirmation to follow, and direct immediate initiation of corrective action. If the Contractor fails to comply promptly, all or any part of the of the work being performed may be stopped by the Engineer with a "stop work order" in accordance with the General Provisions Section **GP-8.07 - Suspension of Work**.
 3. When, in the opinion of the Engineer, satisfactory corrective action has been

taken to correct the unsafe or unhealthy condition, the Contractor will be permitted to resume work. The Contractor shall not be allowed any extension of time or compensation for damages by reason of or in connection with such suspension of work. The Contractor shall insert this clause, with appropriate changes in the designation of the parties, in all subcontracts. At no time shall the Contractor be relieved of the responsibility to be aware of and correct any unsafe condition.

- J. The Contractor shall take all necessary precautions to prevent injury to the public, or damage to property of others. For the purposes of this Contract, the public shall include all persons not employed by the Contractor or a subcontractor working under its direction.
- K. Storing, positioning, or use of equipment, tools, materials, scraps, and trash in a manner likely to present a hazard to the public or building occupants by its accidental shifting, ignition, or other hazardous qualities is strictly prohibited.

SP-6.05 Maintenance of Traffic

The term, Maintenance of Traffic, as used herein, shall include all of such facilities, devices and operations as are required for the safety and convenience of the public as well as for minimizing public nuisance. The Contractor shall control his/her operations and those of his/her subcontractors and all suppliers, to ensure the least inconvenience to the traveling public and the airport operations. Under all circumstances, safety shall be the most important consideration. The Contractor shall maintain the free movement of vehicular traffic with respect to his/her own operations and those of his/her subcontractors and all suppliers. Particular attention is directed to safety on the project during the construction set forth under this Contract, in order that the Contractor's personnel, as well as the general public, will be adequately protected.

- A. The Contractor shall restrict his/her work area as designated on the pre-approved work schedule or as revised and approved by the Engineer as the work progresses. Only vehicles and equipment essential to the particular Contract operation will be allowed on or adjacent to the construction site.
- B. Whenever any materials are dropped or deposited on the Administration's property as a result of hauling operations or other work by the Contractor, or are blown on Administration's property by wind, they shall be removed immediately by the Contractor by sweeping, flushing, or other approved methods as directed by the Engineer. The Contractor shall maintain continuous observation of all paved roads and aprons and shall keep them clear as specified without being so directed by the Engineer. If the Contractor fails to remove materials dropped, tracked, deposited, spilled or blown on the existing roads and aprons, within twenty four (24) hours, the removal will be performed by the Maryland Aviation Administration, and the direct

cost thereof plus one hundred percent (100%) of said cost will be deducted from monies due or to become due the Contractor.

- C. The Contractor shall maintain traffic within the limits of the project as applicable to work for the duration of the construction period, including any temporary suspensions of the work. The work shall include the construction and maintenance of any necessary detour facilities; the providing of necessary facilities for access to tributary roads along the project; the furnishing, installing and maintaining of traffic control and safety devices during construction, the control of dust, and any other special requirements for safe and expeditious movement of traffic. A paved surface shall be provided for lanes being used for the maintenance of traffic. All lanes that are being used for the maintenance of traffic, including those on detours and temporary facilities, shall be adequately maintained, with a substantial surface under all weather conditions. The lanes shall be kept reasonably free of dust and when necessary to accomplish this, they shall be sprinkled with water, or some other dust palliative shall be applied. The lanes on which traffic is to be maintained shall be constructed of materials compatible to the local conditions. The lanes shall be provided with the drainage facilities necessary to maintain an adequately substantial, relatively smooth riding surface under all weather conditions.
- D. The Contractor shall maintain one lane of traffic in each direction. The effective width of each lane used for maintenance of traffic shall be at least as wide as the traffic lanes existing in the area prior to commencement of construction. Traffic control and warning devices shall not encroach on lanes used for maintenance of traffic.
- E. Adequate accommodations for intersecting and crossing traffic shall be provided and maintained and, except where specific permission is given, no road or street crossing the project shall be blocked or unduly restricted.
- F. Except as otherwise provided, the Contractor shall not permit traffic on the base, surface course or structure constructed as part of the work. All traffic shall be maintained outside the limits of such areas until the facility is complete.
- G. When construction operations necessitate vehicle paths other than in the lanes indicated by existing pavement markings, such existing pavement marking as may tend to confuse vehicle operators shall be removed or obliterated as directed.
- H. The Contractor shall conduct his/her operations in such a manner that no undue hazard will result due to the requirements of this Article and the procedures and policies described herein shall in no way act as a waiver of any of the terms of the liability of the Contractor or his/her Surety.
- I. The Contractor will be required to construct and maintain detour facilities wherever it becomes necessary to divert traffic from any existing roadway or bridge, or wherever construction operations block the flow of traffic. The detours are to be planned,

constructed, and maintained in such manner that they will be capable of safely carrying the traffic required in all conditions of weather. The Contractor shall provide the detour with all facilities necessary to meet this requirement. The Contractor will be required to provide all materials for the construction and maintenance of all detours. In general, the requirements of the Technical Provisions pertaining to construction and material details shall not apply to detour construction, and it will be the responsibility of the Contractor to select and to use the construction methods and materials that will provide a stable and safe detour facility.

- J. Supplemented by maintenance, the detour facility shall have sufficient durability to remain in good condition for the entire period that the detour is required.
- K. The Contractor shall remove temporary detours when no longer needed and before the Contract is completed and all materials from the detour not satisfactory for incorporation into the completed work as approved by the Procuring Officer will become the property of the Contractor.
- L. Restrictions on Oversized and Slow-Moving Vehicles: The Contractor may move oversized and/or slow-moving vehicles to the work site over the defined access roads shown on the Contract Drawings or as directed by the Engineer, provided all requirements of the Maryland State Highway Administration have been met.
- M. The Contractor shall furnish, erect, and maintain all necessary barricades, warning signs, and markings for hazards, to protect the public and the work. When used during period of darkness, such barricades, warning signs, and hazard markings shall be suitably illuminated.
- N. For vehicular and pedestrian traffic, the Contractor shall furnish, erect, and maintain barricades, warning signs, lights and other traffic control devices in reasonable conformity with MUTCD.
- O. For contracts requiring Maintenance of Traffic, the Contractor is required to assign a Traffic Manager to the project. Traffic Manager, as a minimum, must have successfully completed State Highway Administration's Work Zone Traffic Control Course and at least three years of progressive responsibility in design, implementation and maintenance of work zone traffic control. Credentials of the person designated as Traffic Manager must be submitted to the Engineer for approval.
- P. Flaggers: The Contractor shall provide competent flaggers to direct traffic in situations as may be required by the standards established herein.

SP-6.06 Occupational Exposure to Lead in Construction Work

The Contractor shall fully comply with the OSHA requirements of 29 CFR 1926.62.

SP-6.07 Safety Hazards in Confined Spaces

A. **The Contractor shall comply with the following, including all appendices, when entering any confined space on Maryland Aviation Administration (MAA) property.**

1. U.S. Department of Labor Occupational Safety and Health Administrations Standards OSHA 29 CFR 1910.146, 'Permit-Required Confined Spaces' and OSHA 29 CFR 1926, 'Safety and Health Regulations for Construction.'
2. The Maryland Occupational Safety and Health (MOSH) requirements of COMAR 09.12.35.

B. **Definitions**

1. **Acceptable entry conditions.** The conditions that must exist in a permit space to allow entry and to ensure that employees involved with a permit-required confined space entry can safely enter into and work within the space.
2. **Attendant.** An individual stationed outside one or more permit spaces who monitors the authorized entrants and who performs all attendant duties assigned in the MAA permit space program.
3. **Authorized entrant.** An employee who is authorized to enter a permit space.
4. **Blanking or blinding.** The absolute closure of a pipe, line, or duct by the fastening of a solid plate (such as a spectacle blind or a skillet blind) that completely covers the bore and that is capable of withstanding the maximum pressure of the pipe, line, or duct with no leakage beyond the plate.
5. **"Confined space" is a space that:**
 - a. Is large enough and so configured that an employee can bodily enter and perform assigned work; and
 - b. Has limited or restricted means for entry or exit (for example, tanks, vessels, silos, storage bins, hoppers, vaults, and pits are spaces that may have limited means of entry); and
 - c. Is not designed for continuous employee occupancy.
6. **Completion:** End of a given task.

7. **Double block and bleed.** The closure of a line, duct, or pipe by closing and locking or tagging two in-line valves and by opening and locking or tagging a drain or vent valve in the line between the two closed valves.
8. **Emergency.** Any occurrence (including any failure of hazard control or monitoring equipment) or event internal or external to the permit space that could endanger entrants.
9. **Engulfment.** The surrounding and effective capture of a person by a liquid or finely divided (flowable) solid substance that can be aspirated to cause death by filling or plugging the respiratory system or that can exert enough force on the body to cause death by strangulation, constriction, or crushing.
10. **Entry.** The action by which a person passes through an opening into all confined space. Entry includes ensuing work activities in that space and is considered to have occurred as soon as any part of the entrant's body breaks the plane of an opening into the space.
11. **Entry permit (permit).** The written or printed document that is provided to allow and control entry into a permit space.
12. **Entry Supervisor.** The person responsible for determining if acceptable entry conditions are present at a permit space where entry is planned, for authorizing entry and overseeing entry operations, and for terminating entry as required by this section (Note: An entry supervisor also may serve as an attendant or as an authorized entrant, as long as that person is trained and equipped as required by this section for each role he or she fills. Also, the duties of entry supervisor may be passed from one individual to another during the course of an entry operation).
13. **Hazardous atmosphere.** An atmosphere that may expose employees to the risk of death, incapacitation, and impairment of ability to self-rescue (that is, escape unaided from a permit space), injury, or acute illness from one or more of the following causes:
 - a. Flammable gas, vapor, or mist in excess of 10 percent of its lower flammable limit (LFL);
 - b. Airborne combustible dust at a concentration that meets or exceeds its LFL (Note: This concentration may be approximated as a condition in which the dust obscures vision at a distance of 5 feet (1.52 m) or less).
 - c. Atmospheric oxygen concentration below 19.5 percent or above 23.5 percent;

- d. Atmospheric concentration of any substance for which a dose
 - e. Any other atmospheric condition that is immediately dangerous to life or health. (Note: For air contaminants for which OSHA has not determined a dose or permissible exposure limit, other sources of information, such as Material Safety Data Sheets that comply with the Hazard Communication Standard published information, and internal documents can provide guidance in establishing acceptable atmospheric conditions).
14. **Hot work permit.** A permit allowing employees to perform work involving welding, cutting, or any task that would deplete oxygen, create toxic fumes and vapors, or create the potential for fire or explosion. MAA's BWI Airport Fire and Rescue Department is the Authorizing Authority.
 15. **Immediately dangerous to life or health (IDLH).** Any condition that poses an immediate or delayed threat to life or that would cause irreversible adverse health effects or that would interfere with an individual's ability to escape unaided from a permit space.
 16. **Inerting.** The displacement of the atmosphere in a permit space by a noncombustible gas (such as nitrogen) to such an extent that the resulting atmosphere is noncombustible. (Note: This procedure produces an IDLH oxygen-deficient atmosphere).
 17. **Isolation.** The process by which a permit space is removed from service and completely protected against the release of energy and material into the space by such means as: blanking or blinding; misaligning or removing sections of lines, pipes, or ducts; a double block and bleed system; lockout or tagout of all sources of energy; or blocking or disconnecting all mechanical linkages.
 18. **Line breaking.** The intentional opening of a pipe, line, or duct that is or has been carrying flammable, corrosive, or toxic material, an inert gas, or any fluid at a volume, pressure, or temperature capable of causing injury.
 19. **Non-permit confined space.** A confined space that does not contain or, with respect to atmospheric hazards, have the potential to contain any hazard capable of causing death or serious physical harm.
 20. **Oxygen deficient atmosphere.** An atmosphere containing less than 19.5 percent oxygen by volume.

21. **Oxygen enriched atmosphere.** An atmosphere containing more than 23.5 percent oxygen by volume.
22. **Permit-required confined space (permit space).** A confined space that has one or more of the following characteristics:
 - a. Contains or has a potential to contain a hazardous atmosphere;
 - b. Contains a material that has the potential for engulfing an entrant;
 - c. Has an internal configuration such that an entrant could be trapped or asphyxiated by inwardly converging walls or by a floor which slopes downward and tapers to a smaller cross-section; or
 - d. Contains any other recognized serious safety or health hazard.
23. **Permit-required confined space program (permit space program).** The MAA overall program for controlling, and where appropriate, for protecting employees from permit space hazards and for regulating employee entry into permit spaces.
24. **Permit system.** The MAA written procedure for preparing and issuing permits for entry and for returning the permit space to service following termination of entry.
25. **Prohibited condition.** Any condition in a permit space that is not allowed by the permit during the period when entry is authorized.
26. **Rescue service.** The personnel designated to rescue employees from permit spaces.
27. **Retrieval system.** The equipment (including a retrieval line, chest or full-body harness, wristlets, if appropriate, and a lifting device or anchor) used for non-entry rescue of persons from permit spaces.
28. **Standby Rescue Team.** Designated rescue personnel that are on site at all times during permit required entries, and are trained to the OSHA requirements for Confined Space Rescue.
29. **Testing.** The process by which the hazards that may confront entrants of a permit space are identified and evaluated. Testing includes specifying the tests that are to be performed in the permit space (Note: Testing enables employers both to devise and implement adequate control measures for the protection of authorized entrants and to determine if acceptable entry conditions are present immediately prior to, and during, entry).

C. The Contractor shall include his confined space entry program as part of the overall safety program and shall include the following:

1. Contactors shall follow, as applicable, OSHA 29 CFR 1910.146, "Permit-Required Confined Spaces" and OSHA CFR 1926, "Safety and Health Regulation for Construction," and the Code of Maryland (COMAR) 09.12.35, "Maryland Occupational Safety and Health Standards for Confined Spaces" when entering any confined space on Maryland Aviation Administration property.
2. Contractors who are required to enter into any confined space on MAA property shall be required to have successfully completed an OSHA compliant Confined Space Entry training course on Permit and Non-Permit entries prior to performing this task.
3. Contractors entering confined spaces on MAA property at BWI Marshall shall notify all entries in advance through BWI Airport Fire & Rescue Department On-Duty Division Chief of Operations, 410-859-7709.
4. Contractors entering confined spaces on Martin State Airport (MTN) property shall schedule all entries in advance with the MTN Operations Center, 410-682-8831.
5. Contractors shall provide **their own STANDBY** Rescue Team for all Immediately Dangerous to Life and Health (IDLH) permit required confined spaces.
6. Contractors shall be required to have rescue equipment and personnel trained in confined space rescue on site and in place to perform rescue during IDLH permit required confined space entries on MAA property.
7. Contractors shall be required to have a communications device capable of notifying the emergency services at BWI Marshall (410-859-7222) or emergency services at Martin State Airport (911) in the event of a fire, medical emergency or confined space rescue incident.
8. In instances where MAA and Contractor employees are working simultaneously as authorized entrants in a permit space, the Contractor shall coordinate entry operations with the Engineer, MAA's Office of Maintenance and Utilities and MAA's Employee Risk Management Coordinator so that MAA and Contractor employees do not endanger each other.
9. The Contractor's Entry Supervisor shall be required to use and fill out the appropriate MAA confined space forms listed below. All forms listed below

shall be used for all confined space entries on MAA property. Forms are attached.

- a. **MAA-017 B – Confined Space Evaluation Form** This is to determine Permit or Non-Permit Required Confined Space.
- b. **MAA-017 C – Confined Space Entry Permit** (Contractor may substitute his own form if it contains the same information). The permit shall be on location at all times during entry.
- c. **MAA-017 F – Confined Space Entry Critique/Review Form.** This form shall be used after each confined space entry on MAA property.
- d. **MAA-27 A – BWI Airport Welding & Burning Permit** (MAA's BWI Airport Fire & Rescue Department is the Authorizing Authority). This form shall be used during any hot work, following FRD's policy.
- e. **MAA-27 B – Martin State Airport Welding & Burning Permit** (MAA's BWI Airport Fire & Rescue Department is the Authorizing Authority). This form shall be used during any hot work, following FRD's policy.

The Entry Supervisor shall forward all completed forms to the Division of Employee Risk Management within 24 hours of the completion of the entry, FAX is acceptable.

MAA Division of Employee Risk Management
P.O. Box 8766
BWI Airport, MD 21240
410-859-7509 (Phone)
410-859-7114 (Fax)



Confined Space Entry Evaluation Form

NOTE: When completing this form, ensure that a response is provided for each question and at each entry.

Building Location: _____ Date: _____
Description of the space (including name and number): _____

SECTION 1. CONFINED SPACE ASSESSMENT

- Is the space large enough and configured that an employee can bodily enter and perform assigned work? YES NO
- Does the space have limited or restricted means for entry or exit? YES NO
- Is the space not designed for continuous employee occupancy? YES NO

If the answers to these three questions are "YES", it is a Confined Space and the questions in Section 2 must be completed.

IF THE ANSWER TO ANY QUESTION IS "NO", PLEASE EXPLAIN.

SECTION 2. PERMIT-REQUIRED CONFINED SPACE

Does the confined space:

- Contain or have the potential to contain a hazardous atmosphere? YES NO
- Contain or have the potential to contain a hazardous atmosphere? YES NO
- Contain any hazard capable of causing death or serious injury? YES NO
- Have an internal configuration that could trap or asphyxiate an entrant by inwardly sloping walls or tapering floors? YES NO
- Contain any other recognized serious safety or health hazard? YES NO

If the answers to the questions are "NO", the location is a Non-Permit-Required Confined Space. If the answer to any question is "YES", the questions in Section 3 must be completed.

- Does the space contain or have the potential to contain any of the following hazardous atmospheres? YES NO
 - A flammable gas, vapor, or mist in excess of 10% of its lower explosive limit (LEL)? YES NO
Identify the hazard(s) _____
 - Airborne combustible dust at a concentration that meets or exceeds its LEL? YES NO
 - An atmospheric oxygen concentration below 19.5% or above 23.5%? YES NO
 - An atmospheric oxygen concentration of any substance that is capable of causing death, incapacitation, impairment of ability to self-rescue, injury or acute illness? YES NO
Identify the hazard(s) _____
- Does the Permit-Required Confined Space contain a material that presents the potential to engulf an entrant? YES NO
Identify the hazard(s) _____
- Does the Permit-Required Confined Space have an internal configuration such an entrant could be trapped or asphyxiated by inwardly converging walls of by a floor, which slopes downward, and taper to a small cross section? YES NO
- Does the Permit-Required Confined Space contain any other recognized serious safety or health hazard? YES NO
Identify the hazard(s) _____

If the answer to any of the questions in Section 3 is “YES”, the location is a Permit-Required Confined Space and warning signs must be posted at each entrance.

POSTING REQUIREMENTS

SURVEY DOCUMENTATION

- Identify the number of entrances to be posted.

- Identify the location of each entrance, if not readily apparent.

Survey Conducted By:
Name: _____ Date: _____

Survey Reviewed By:
Name: _____ Date: _____

Survey Conducted By:
Name: _____ Date: _____



Maryland Aviation Administration

Confined Space Entry Permit

Page 1 of 2

THE PERMIT REMAINS AT THE JOB SITE UNTIL THE ENTRY IS COMPLETED AND IS THEN FORWARDED TO THE MAA RISK MANAGER

LOCATION OF PERMIT-REQUIRED CONFINED SPACE: _____

DESCRIPTION OF SPACE: _____

PURPOSE OF ENTRY: _____

ENTRY DATE / TIME: _____

EXPECTED DATE /TIME OF EXPIRATION: _____

HAZARDS IN THE SPACE _____

PLANNING FOR ENTRY	YES	N/A		YES	N/A
LOCKOUT DE-ENERGIZE – IDENTIFY THE SYSTEM TO BE SHUTDOWN:			FIRE EXTINGUISHERS		
LINES BROKEN - CAPPED OR BLANKED			COMMUNICATION SYSTEM Type: _____		
PURGE - FLUSH AND VENT			LIGHTING (EXPLOSION PROOF)		
VENTILATION			PROTECTIVE CLOTHING		
SECURE AREA - (STANCHION AND TAPE)			RESPIRATOR		
BREATHING APPARATUS (SCBA)			GLOVES		
RETRIEVAL HARNESS REQUIRED			SAFETY GLASSES		
RETRIEVAL SYSTEM REQUIRED			HOT WORK PERMIT		
LIFELINES			OTHER		

Make of Monitor: _____ Model: _____

REQUIREMENTS FOR ATMOSPHERIC TESTING

DATE
TESTER
TIME

		AM/PM	AM/PM	AM/PM	AM/PM	AM/PM	AM/PM	AM/PM
CONCENTRATION	ACCEPTABLE ENTRY LEVEL							
% OF OXYGEN	19.5% - 23.5%							
% OF LEL AND IDENTIFY THE GAS/VAPOR/MIST	< 10% of the LEL							
TOXIC GAS	Consult with Safety Office							
Other	Consult with Safety Office							

MAA-017 (C) R 1-06



Maryland Aviation Administration

Confined Space Entry Permit

Page 2 of 2

NOTE: ENTRY INTO A PERMIT-REQUIRED CONFINED SPACE IS NOT PERMITTED UNLESS ACCEPTABLE ENTRY LEVELS ARE MAINTAINED

EQUIPMENT CALIBRATION	Monitoring Equipment:	Monitoring Equipment:	Monitoring Equipment:
Parameter			
Frequency of testing			
Results of Pre-Calibration			
Results of Post-Calibration			
Name of Tester/Date/Time			

Authorized Entrants

Authorized Attendants

Authorized Entry Supervisors

PERMIT AUTHORIZATION BY THE ENTRY SUPERVISOR:

I certify that actions necessary for safe entry and the completion of work have been completed and that conditions are acceptable for entry.

NAME _____

DATE/TIME _____

SIGNATURE _____

PERMIT CANCELLATION:

The entry was:

COMPLETED / TERMINATED

NAME _____

SIGNATURE _____

DATE _____ TIME _____

NOTES/COMMENTS _____

Emergency Telephone Number for Rescuer: _____

Fire Department Notified and Visited Site (Pre-plan Only): _____ Date: _____

Fire Department Signature: _____ Rank: _____

BWI Airport Fire & Rescue Department, Phone 410-859-7222

Martin State Airport 911
MAA-017 (C) R 1-06

Related Forms MAA-017 [A](#), [B](#), [D](#), [E](#), [F](#), [G](#), [H](#), [I](#)



Maryland Aviation Administration

Confined Space Entry Critique/Review Sheet

Entry Date: _____ Job Number: _____

Job Description: _____

Confined Space Entry Number: _____

Division/Contractor Name: _____

Contractor Address: _____

Location of Entry: _____

What went well? _____

What needs Improvements? _____

MAA-017 (F) R 1-06
Related Forms MAA-017 [A](#), [B](#), [C](#), [D](#), [E](#), [G](#), [H](#), [I](#)

**MARYLAND DEPARTMENT OF TRANSPORTATION
MARYLAND AVIATION ADMINISTRATION
BWI AIRPORT WELDING AND BURNING PERMIT**

SECTION A		
BUILDING AND LOCATION:	_____	
COMPANY NAME:	_____	
ADDRESS:	_____	
PHONE NUMBER:	_____	
PERMIT REQUESTED BY: <i>(please print name)</i>	_____	
PROJECT DESCRIPTION:	_____	
SECTION B		
WORK DATES:	START: ___/___/___	END: ___/___/___
APPROX. WORK HOURS:	FROM: _____	TO: _____
SECTION C		
<p>CONTRACTOR MUST NOTIFY THE FIRE-RESCUE SERVICE COMMUNICATIONS CENTER AT 410-859-7117 or 7118 PRIOR TO STARTING ANY WORK, AND ALSO AT THE COMPLETION OF EACH DAY OR SHIFT. IN CASE OF EMERGENCY, PLEASE DIAL 410-859-7222.</p>		
_____	_____	___/___/___
CONTRACTOR'S SIGNATURE	PLEASE PRINT NAME	DATE
SECTION D		
<p>CONTRACTOR IS AWARE OF THE NATIONAL FIRE PROTECTION ASSOCIATION, STANDARD NO. 51B, AND THE STATE FIRE PREVENTION CODE, NFPA-1, CHAPTER 18, SECTION 18-1 THROUGH 18-3 (LATEST EDITION). IF NOT AWARE OF THESE STANDARDS AND CODES, CONTRACTOR MUST REVIEW EACH PRIOR TO SIGNING BELOW.</p>		
<p>I HAVE READ AND UNDERSTAND THE STANDARDS & CODES AS OUTLINED IN SECTION D, PARAGRAPH ABOVE:</p>		
_____	_____	___/___/___
CONTRACTOR'S SIGNATURE	PLEASE PRINT NAME	DATE
SECTION E		
<p>FAILURE TO COMPLY WITH SECTIONS C & D OF THIS PERMIT WILL RESULT IN REVOCATION OF PERMIT AND THE IMMEDIATE STOPPAGE OF ALL WORK. ALARMS GENERATED BY WELDING/BURNING DUE TO NEGLECT OR ACCIDENTAL ACTIVATION OF A FIRE ALARM SYSTEM MAY RESULT IN A CIVIL CITATION AS OUTLINED UNDER ARTICLE 27, §156 A., B., & C. OF THE ANNOTATED CODE OF MARYLAND.</p>		
_____	_____	___/___/___
CONTRACTOR'S SIGNATURE	PLEASE PRINT NAME	DATE
SECTION F		
BWI AIRPORT FIRE AND RESCUE DEPARTMENT AUTHORIZATION		
_____	_____	___/___/___
AUTHORIZING SIGNATURE	PLEASE PRINT NAME	DATE
INSPECTED BY	EMPLOYEE #	

Original - Contractor

Canary - CDC

Pink- Fire and Rescue Department

MAA.077 A R7-03

NOTE: THIS FORM SHALL BE OBTAINED FROM THE BWI AIRPORT FIRE & RESCUE DEPARTMENT.

SP-6.08 Call-Back Roster

The Contractor shall provide and maintain a prioritized list of personnel to be contacted during emergency situations who can respond to emergencies and/or have the authority to direct other employees to respond to such emergencies. This list shall contain the names and phone numbers of those individuals. The Contractor shall immediately advise the Engineer, in writing, as changes are made to the list.

SP-6.09 Temporary Support of Excavation

1.0 General

In general, excavations shall be supported. However, if the contract documents do not require a supported excavation and sufficient space is available, the Contractor can use open excavations with suitable side slopes. The open excavation shall be designed by a qualified geotechnical engineer in accordance with OSHA Regulations described in Federal Register, Volume 54, No. 209, October 31, 1989, Rules and Regulations. Open cuts, including partial sloping cuts above the proposed support, shall be reviewed on a case-by-case basis. Unless noted otherwise in this specification, the design and details of the temporary support of excavation shall meet the requirements of the following Codes, Standards or Manuals:

- (a) AASHTO - Standard Specifications for Highway Bridges, 1992.
- (b) Maryland Department of Transportation, State Highway Administration Standard Specifications for Construction and Materials, 1993.
- (c) USS Steel Sheet Piling Design Manual, Updated and Reprinted by FHWA, July 1984.
- (d) Federal Register, Volume 54, No. 209, October 31, 1989, Rules and Regulations.

2.0 Temporary Vertical-Walls and Cofferdams

2.1 Description

The design of temporary structures required for the support of excavations shall be the sole responsibility of the contractor. Design calculations and drawings stamped and prepared by a Registered Professional Engineer specializing in Geotechnical Engineering with a minimum of five years experience and registered in the State of Maryland are required. Qualifications of the Registered Professional Engineer should be submitted to the Engineer for his approval within two weeks of the Notice to Proceed.

The Contractor must submit Support of Excavation shop drawings and calculations to the Engineer at least 7 days prior to the start of the construction for support of excavation. The shop drawings and calculations should be submitted, along with a cover letter, certifying that support of excavation design has been done in conformance with these Support of Excavation specifications.

The following list of items summarizes the minimum conditions which shall be considered in the design of temporary vertical-walls or cofferdams.

2.2 Earth Pressures and Surcharge Loadings

The active earth pressure coefficient, K_a , and the passive earth pressure coefficient, K_p , shall be estimated assuming wedge theory based upon a planar surface of sliding as defined by Coulomb theory. The effective angle of internal friction and unit weight used to compute K_a , and K_p shall be based upon available geotechnical information at the site with appropriate consideration given to assigning effective ϕ values for cohesive material where the sloping surcharge case must be considered. The value of the friction angle, δ , between the soil and the retaining wall, used for computing the value of K_a and K_p shall not exceed one-third of the value of the effective angle of internal friction, ϕ , of the soil. The effect of the slope angles, β and β' , shall be considered when evaluating K_a and K_p .

2.3 Width of Discrete Wall Elements

Where discrete vertical wall elements (soldier beams) are used for support, the width of each vertical element shall be assumed equal to the width of the flange or diameter of the element for driven sections and the diameter of the concrete-filled hole for sections encased in concrete.

2.4 Simplified Earth Pressure Distribution from a Retained Granular Soil on a Temporary Flexible Cantilever Retaining Wall or a Temporary Flexible Retaining Wall Supported by One Tier of Bracing or Tie Backs; Reference-AASHTO, 92

A triangular earth pressure diagram shall be used, having a horizontal ordinate equal to $K_{a1} \gamma'_1 h$ at any depth h (see Figures 1 and 4).

Where:

γ'_1 = effective unit weight of retained soil

h = any depth of excavation

K_{a1} = coefficient of active earth pressure of retained soil

2.5 Simplified Earth Pressure Distribution from a Retained Cohesive Soil on a Temporary Flexible Cantilever Retaining Wall or Temporary Flexible Retaining Wall Supported by One Tier of Bracing or Tiebacks; Reference -AASHTO, 92

A triangular earth pressure diagram shall be used. At the top of the wall, the lateral ordinate of the triangle shall be zero, increasing linearly to a value equal to $\gamma'_1 H - 2s_{u1}$ at the final excavation level, i.e., at the total depth, H, from the top of the wall (see Figures 2 and 3).

Where:

s_{u1} = undrained shear strength of the retained cohesive soil.
H = total depth of excavation

Also, the addition of water pressure shall be considered on the supporting wall due to the possibility of water in tension cracks. Also, the following restrictions shall apply:

2.5.1 The active earth pressure shall not be less than 0.25 times the effective overburden pressure at any depth.

2.5.2 For sloping cuts above the proposed support system, use the effective shear strength parameters ($c=0$, ϕ) and the simplified earth pressure distribution in accordance with Section 2.4 of this specification.

2.6 Simplified Earth Pressure Distribution on a Portion of Continuous Vertical Wall Element of a Temporary Flexible Cantilevered Wall or the Portion of Temporary Flexible Wall Supported by One or More Tiers of Bracing or Tiebacks Embedded in Granular Soils; Reference - AASHTO, 92

A triangular diagram for the resultant or net passive resistance shall be used, having a horizontal ordinate equal to $(K_{p2} - K_{a2}) \gamma'_2 d - K_{a2} \gamma'_1 H$ at any depth, d, below the final excavation (see Figures 1 and 2).

Where:

γ'_2 = effective unit weight of soil below the final excavation
d = any depth of embedment below the final excavation
 K_{a2} = coefficient of active earth pressure of soil below final excavation
 K_{p2} = coefficient of passive earth pressure of soil below final excavation

2.7 Simplified Earth Pressure Distribution on a Portion of Continuous Vertical Wall Element of Temporary Flexible Cantilevered Wall or the Portion of a Temporary Flexible Wall Supported by One or More Tiers of Bracing or Tiebacks Embedded in Cohesive Soils; Reference AASHTO, 92

A rectangular diagram for the resultant or net passive resistance shall be used, having a horizontal ordinate equal to $4s_{u2} - \gamma'_1 H$ (see Figures 3 and 4).

Where:

s_{u2} = undrained shear strength of the cohesive soil below the final excavation.

- 2.8 Simplified Earth Pressure Distribution from Granular or Cohesive Soils on the Embedded Portions of Discrete Vertical Wall Elements of Temporary Flexible Cantilevered Walls or of Temporary Flexible Walls Supported by One or More Tiers of Bracing or Tiebacks; Reference -AASHTO, 92.

The procedure for determining the resultant passive resistance of a discrete vertical element embedded in soil shall be based on the net passive resistance mobilized by three times the element width or diameter, not to exceed the soldier pile spacing. A depth of 1.5 times the width of the element shall be discounted in developing passive lateral resistance (see Figures 5 through 8).

2.9 Construction Equipment and Traffic Loading Surcharge

Surcharge pressures must be added to the earth pressures computed in accordance with Sections 2.4 through 2.8 of this specification. A minimum construction loading surcharge of 600 psf shall be applied to all design cases. A higher value shall be used if applicable. The effect of restricting construction loads from the face of the supporting wall also may be considered.

2.10 Ground Water Pressures

Ground water pressures must be added to the earth pressures computed in accordance with Sections 2.4 through 2.8 of this specification. Where soldier piles with timber lagging are used ground water is generally assumed to be below subgrade of the interior excavation. When the wall is intended to prevent all leakage of ground water (tight sheeting), maximum exterior ground water pressures should be used.

3.0 Simplified Design Procedure for Retaining Walls

3.1 Cantilever Walls

- (a) Determine earth pressure diagram and net passive resistance diagram in accordance with Sections 2.2 through 2.10 of this specification.
- (b) Sum moments about toe of the embedment to determine the embedment depth, D_0 , for which the net passive resistance is sufficient to provide equilibrium.
- (c) Determine the depth at which the shear in the wall is zero.
- (d) Calculate the maximum bending moment at the point of zero shear.
- (e) Calculate the design depth (D_d) of embedment, $D_d = 1\theta 2 D_0$ to $1\theta 4 D_0$.

3.2 Walls Supported by One Tier of Tiebacks

- (a) Determine earth pressure diagram and net passive resistance diagram in accordance with Section 2.2 through 2.10 of this specification.
 - (b) Sum moments about the location of brace or tieback to determine the embedment depth, D_0 , for which the net passive resistance is sufficient to provide equilibrium.
 - (c) Sum horizontal forces to determine the horizontal force in the brace or tieback.
 - (d) Determine depth below the brace or tieback at which the shear in the wall is zero.
 - (e) Calculate the maximum bending moment at the point of zero shear.
 - (f) Calculate the design depth (D_d) of embedment, $D_d = 1.02 D_0$, to $1.04 D_0$.
- 4.0 Simplified Earth Pressure Distributions from Various Soils on Temporary Flexible Walls Supported by Two or More Tiers of Tiebacks or Braces; Reference-AASHTO 92.
- 4.1 For granular soils, a rectangular earth pressure diagram shall be used, having a horizontal ordinate equal to $0.65 K_a \gamma' h$ at any depth, h , below the top of the wall.
- 4.2 For soft to medium stiff clay, a trapezoidal earth pressure diagram shall be used with horizontal ordinate increasing from zero at the top of the wall, to $K_a \gamma H$ at a depth equal to $0.25H$. The horizontal ordinate shall remain constant at $K_a \gamma H$ from depths between $0.25H$ and H .

Where:

$K_a = 1 - m(2q_u/\gamma H)$ but not less than 0.25

$m = 1$ for overconsolidated clays
 $= 0.4$ for normally consolidated clays

$\gamma =$ total unit weight of clay

$q_u =$ unconfined compressive strength of clay

- 4.3 For stiff to hard clay, a trapezoidal earth pressure diagram shall be used with the horizontal ordinate increasing from zero at the top of wall to $0.4\gamma H$ at a depth equal to $0.25H$. The horizontal ordinate shall remain constant at a rectangular earth pressure diagram $0.4\gamma H$ for depths between $0.25H$ and $0.75H$, and then decrease to zero at a depth equal to H .

4.4 Surcharge and water pressure shall be added to the earth pressures in accordance with Sections 2.9 and 2.10 of this specification.

5.0 Sheeting, Walers, Braces, Tiebacks and Struts

5.1 Struts, braces and walers should be sized for the above loads at normal allowable working stresses to which it will be subjected in the various construction stages using the appropriate pressure diagrams computed in accordance with Section 4 of this specification. The effect of combined axial and flexural loading, unsupported span lengths and lateral stability of the members must be considered.

For the design of braces, tiebacks, struts, walers and sheeting, the appropriate pressure diagrams computed in accordance with Section 4 of this specification shall be applied for final excavation conditions assuming struts, walers and sheeting to be hinged at brace points, except the uppermost brace point.

5.2 Sheeting, walers, braces, tiebacks and struts must be designed for each intermediate loading condition when portions of the structure or facilities are completed and the lower tiebacks, braces, or struts are removed. Consideration must be given to the possible increase in loading on the upper tiebacks, braces, or struts remaining in place, using some reasonable allowance for arching in the span between the completed structure and the lowest tieback, brace, or strut then in place.

6.0 Timber Lagging

Structural grade timber lagging shall be of the following thicknesses, unsurfaced:

Depth	Required Thickness of Timber Lagging for Clear Spans (S) of:	
	5' < S < 8'	8' < S < 10'
From ground surface to 25 feet	3±	4±
From 25 feet to 60 feet	4±	5±

The lagging shall be of a timber specie and grade that will provide an allowable working stress of not less than 1,100 psi. In the case of greater soldier pile spacing or the presence of unusually heavy construction surcharge on particularly soft cohesive soils, greater thicknesses of lagging may be required.

7.0 Working Stress Method

All members in the support structure should be sized using the Working Stress Method as discussed in the AISC Code. Design calculations must consider the effects of combined axial, torsional and flexural loads in the structure. Also, the stability of laterally unsupported members and unsupported span lengths shall be considered.

8.0 Tiebacks or Braces

In general, excavations deeper than 12 feet must be braced or supported by tiebacks. The vertical spacing of tiers of tiebacks or braces below the first tier should not exceed 16 feet center to center during excavation. Where the excavation is near a structure and it is desired to minimize movement of the structure, in lieu of underpinning, the vertical spacing shall not exceed 12 feet, center to center, during excavation. The necessity to remove intermediate braces or tiebacks during construction should be compensated for by increased stiffness of soldier piles.

9.0 Soldier Pile and Lagging Wall

Soldier piles shall be driven or installed in prebored holes. The installed soldier piles should be within a vertical tolerance of 3 inches per 25 feet of length.

Concrete spacers or other approved non-corrosive centering devices shall be used at sufficient intervals to insure concentric spacing for the entire length of pile installed in prebored holes.

After placing the soldier pile, the shaft shall be filled with concrete, having a 28-day strength of 3,500 psi from the bottom of the drilled shaft to the dredge line. A lean mix shall be placed in the remainder of the drilled shaft, where lagging is to be installed, completely encasing the pile. Concrete shall be allowed to cure for 72 hours before any excavation may take place.

As the excavation in front of the wall proceeds, timber lagging shall be wedged behind the flange of the soldier piles. The maximum height of unlagged face of excavation shall be established by the designer but shall, in general, not exceed two feet. The unlagged face shall not exceed 15 inches if water flows from face of excavation or if the soil face moves toward the excavation.

Packing shall be done to establish tight contact between the excavation face and the lagging. Openings between lagging shall be packed with suitable material which will not decay and will allow free drainage of water without loss of soil or packing.

If unstable material is encountered during excavation, measures shall be taken to contain the unstable material in place and prevent ground displacement. Sufficient quantity of material shall be maintained on hand for lagging, shoring, bracing and other operations for protection of work and for use in case of accident or emergency.

10. **Working or Shop Drawings**

Details on working drawings shall show appropriate means of posting of struts and walers, lacing struts in both vertical and horizontal planes to provide lateral stability, web and connection stiffeners, brackets, and provisions for wedging and jacking of struts to prevent horizontal movement. Details are a vital element in the adequacy and safety of temporary earth retaining structures and shall be shown completely on the working drawings in conjunction with the methods and sequence of installation of all elements of the structure. Particular attention shall be given to procedures for wedging or jacking of all bracing members to maintain tight contact and to provide for uniformity of load distribution.

Complete details of tiebacks, if used, shall be shown in the shop drawings.

11. **Contractor's Submission**

The Contractor's submission shall include computations for each stage of the installation of the support system, whether it is supported by cantilevering or bracing. The design shall indicate that the system is stable both internally and externally. It shall also show that the embedment is sufficiently deep to prevent piping and potential ground loss at the bottom.

No overstress shall be allowed in the design of members in compression.

12. **Control of Ground Water**

The Contractor shall control ground water at the site. This shall include control of stormwater runoff from adjacent ground and structures, methods to control and prevent erosion, and methods to control loss of ground during excavation.

13. **Adjacent Structures**

The design of all members must include the effects of loads of street traffic, construction equipment, supported utilities, adjacent structures which are not underpinned, and any other loads that must be carried by the support of excavation system during the construction period.

14. **Review of Shop Drawings and Calculations**

A period of 10 days should be allowed for the initial review of shop drawings and calculations submitted by the Contractor. Seven days should be allowed for each successive review as required. The Contractor shall start the construction of the support of excavation only after the shop drawings have been approved.

15. **Method of Measurement and Basis of Payment**

The work of designing, preparing shop drawings, furnishing, installing, maintaining, and removing the support of excavation system, where required, will not be measured for payment. Rather, the support of excavation system is considered to be incidental to the work required for excavation including the segregation of the excavated material into suitable and unsuitable materials, hauling, storing, rehandling, depositing, backfilling, compacting, disposal, etc. All costs associated with the designing, preparation of shop drawings, furnishing, installation, and removal of the support of excavation system including pumping, bailing, draining, dewatering devices, and removal thereof, and all other labor, equipment, tools, and incidentals necessary to complete the item, shall be included in the appropriate unit price bid items for "Structural Excavation" or other relevant sections.

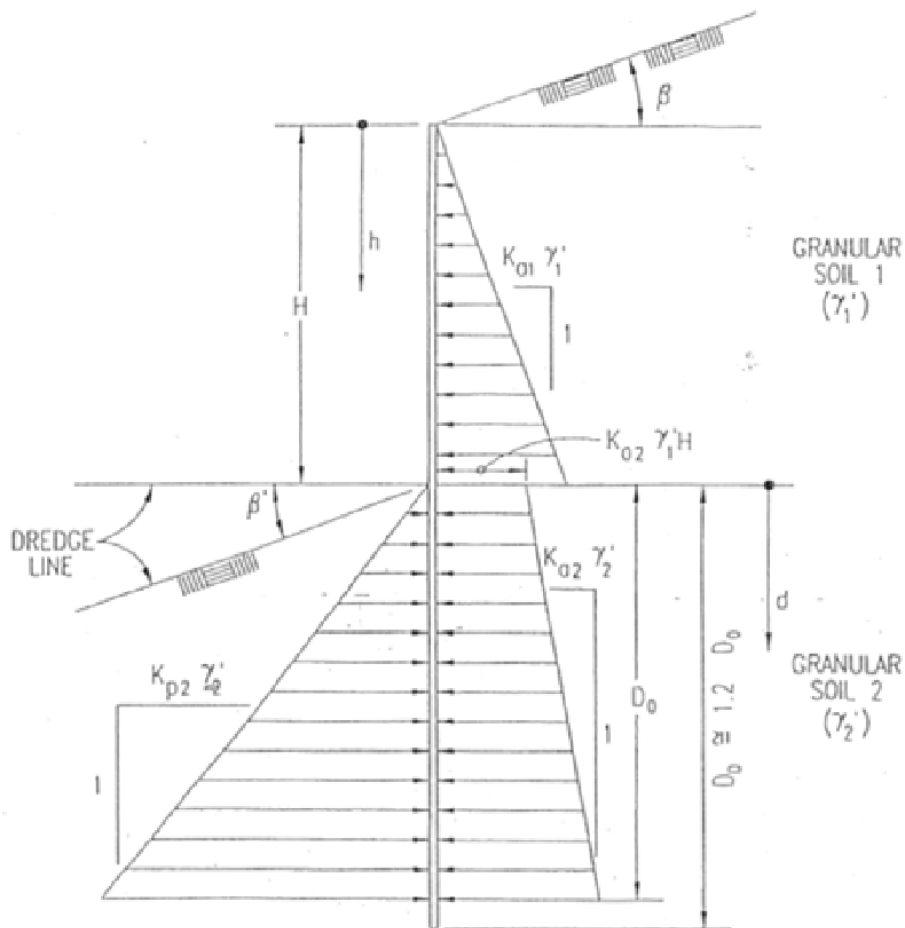

PRESSURE DISTRIBUTION

- NOTES:**
- (1) SURCHARGE AND WATER PRESSURES MUST BE ADDED TO THE ABOVE EARTH PRESSURES.
 - (2) FORCES SHOWN ARE PER HORIZONTAL FOOT OF VERTICAL WALL ELEMENT.

SIMPLIFIED EARTH PRESSURE DISTRIBUTION FOR TEMPORARY FLEXIBLE CANTILEVER WALLS WITH CONTINUOUS VERTICAL WALL ELEMENTS - RETAINING GRANULAR SOIL WITH EMBEDMENT IN GRANULAR SOIL

Greiner

GREINER, INC.
CONSULTING ARCHITECTS/ENGINEERS
BETHESDA, MARYLAND

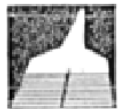

BWI

MARYLAND DEPARTMENT OF TRANSPORTATION
BARTLAND AVIATION ADMINISTRATION
OFFICE OF ENGINEERING

BALTIMORE/WASHINGTON
INTERNATIONAL AIRPORT

DATE

SIMPLIFIED EARTH PRESSURE
DISTRIBUTION FOR TEMPORARY
SUPPORT OF EXCAVATION

DATE
JULY, 1995
(REV. FEB. 1996)

FIGURE NO.
1

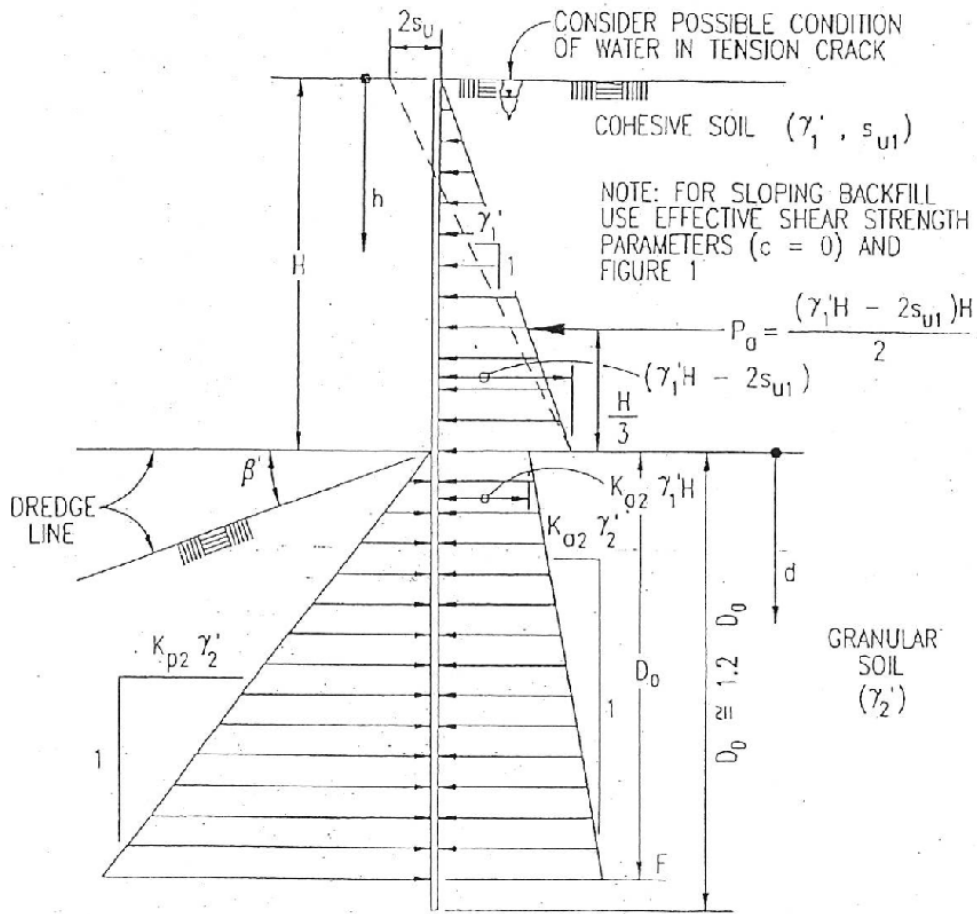

PRESSURE DISTRIBUTION

- NOTES:**
- (1) SURCHARGE AND WATER PRESSURES MUST BE ADDED TO THE ABOVE EARTH PRESSURES.
 - (2) FORCES SHOWN ARE PER HORIZONTAL FOOT OF VERTICAL WALL ELEMENT.

SIMPLIFIED EARTH PRESSURE DISTRIBUTION FOR TEMPORARY FLEXIBLE CANTILEVER WALLS WITH CONTINUOUS VERTICAL WALL ELEMENTS – RETAINING COHESIVE SOIL WITH EMBEDMENT IN GRANULAR SOIL

Greiner
GREINER, INC.
CONSULTING ARCHITECTS/ENGINEERS
BETHESDA, MARYLAND



BWI

MARYLAND DEPARTMENT OF TRANSPORTATION
BALTIMORE AND WASHINGTON AIRPORT AUTHORITY
DIVISION OF ENGINEERING

BALTIMORE/WASHINGTON
INTERNATIONAL AIRPORT

TITLE
SIMPLIFIED EARTH PRESSURE
DISTRIBUTION FOR TEMPORARY
SUPPORT OF EXCAVATION

DATE
JULY, 1995
(REV. FEB. 1996)

FIGURE NO.
2

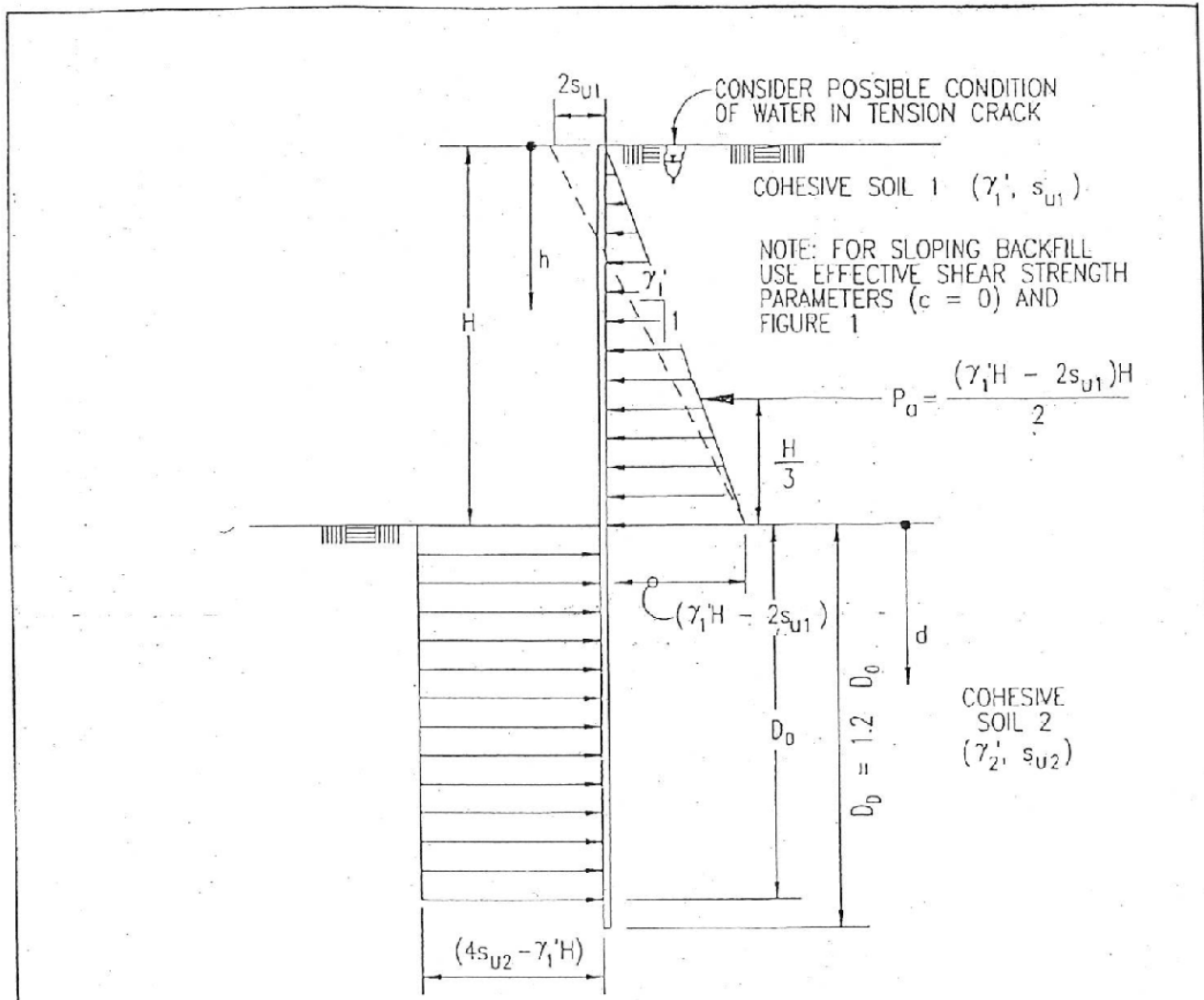

PRESSURE DISTRIBUTION

- NOTES:
- (1) SURCHARGE AND WATER PRESSURES MUST BE ADDED TO THE ABOVE EARTH PRESSURES.
 - (2) FORCES SHOWN ARE PER HORIZONTAL FOOT OF VERTICAL WALL ELEMENT.

SIMPLIFIED EARTH PRESSURE DISTRIBUTION FOR TEMPORARY FLEXIBLE WALLS WITH CONTINUOUS VERTICAL WALL ELEMENTS - RETAINING COHESIVE SOIL WITH EMBEDMENT IN COHESIVE SOIL

<p>Greiner GREINER, INC. CONSULTING ARCHITECTS/ENGINEERS BETHESDA, MARYLAND</p>	<p>BWI BALTIMORE/WASHINGTON INTERNATIONAL AIRPORT</p>	<p>FILE SIMPLIFIED EARTH PRESSURE DISTRIBUTION FOR TEMPORARY SUPPORT OF EXCAVATION</p> <p>DATE JULY, 1995 (REV. FEB. 1996)</p> <p>FIGURE NO. 3</p>
----------------------------------------------------------------------------------------------------	----------------------------------------------------------------------	--------------------------------------------------------------------------------------------------------------------------------------------------------------------

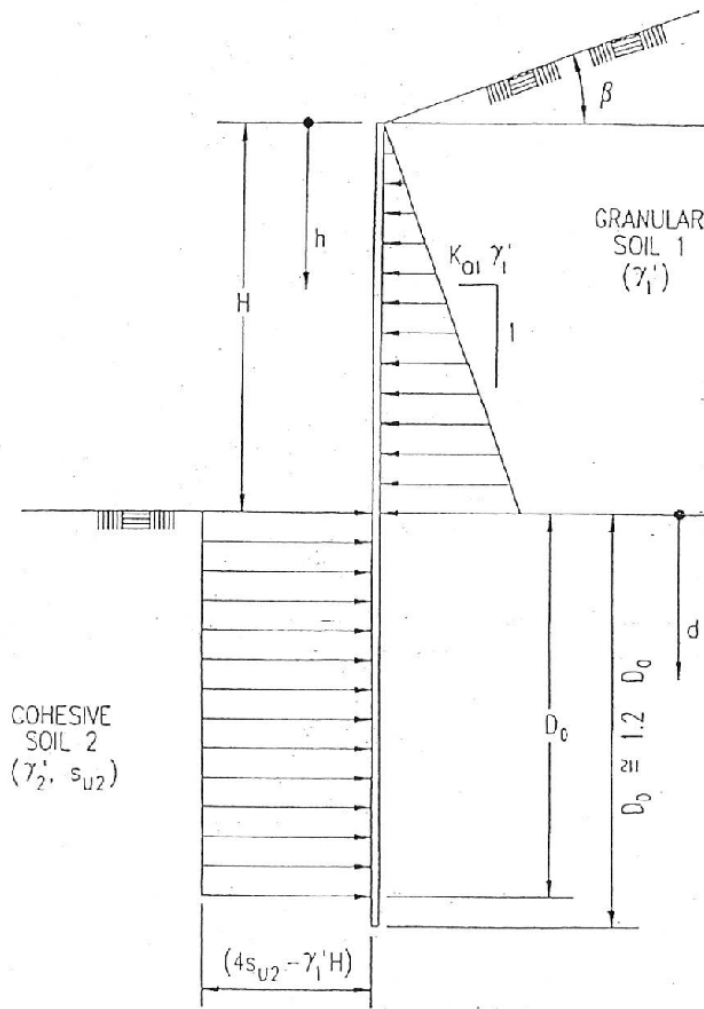

PRESSURE DISTRIBUTION

- NOTES: (1) SURCHARGE AND WATER PRESSURES MUST BE ADDED TO THE ABOVE EARTH PRESSURES.
 (2) FORCES SHOWN ARE PER HORIZONTAL FOOT OF VERTICAL WALL ELEMENT.

SIMPLIFIED EARTH PRESSURE DISTRIBUTION FOR TEMPORARY FLEXIBLE WALLS WITH CONTINUOUS VERTICAL WALL ELEMENTS - RETAINING GRANULAR SOIL WITH EMBEDMENT IN COHESIVE SOIL

Greiner

GREINER, INC.
 CONSULTING ARCHITECTS/ENGINEERS
 FORTSMOORE, MARYLAND



BW/1

MARYLAND DEPARTMENT OF TRANSPORTATION
 MARYLAND AVIATION ADMINISTRATION
 SYSTEMS OF EXPERIMENTAL

BALTIMORE/WASHINGTON
 INTERNATIONAL AIRPORT

TITLE

SIMPLIFIED EARTH PRESSURE
 DISTRIBUTION FOR TEMPORARY
 SUPPORT OF EXCAVATION

DATE

JULY, 1995
 (REV. FEB. 1995)

FIGURAL NO.

4

The picture can't be displayed.

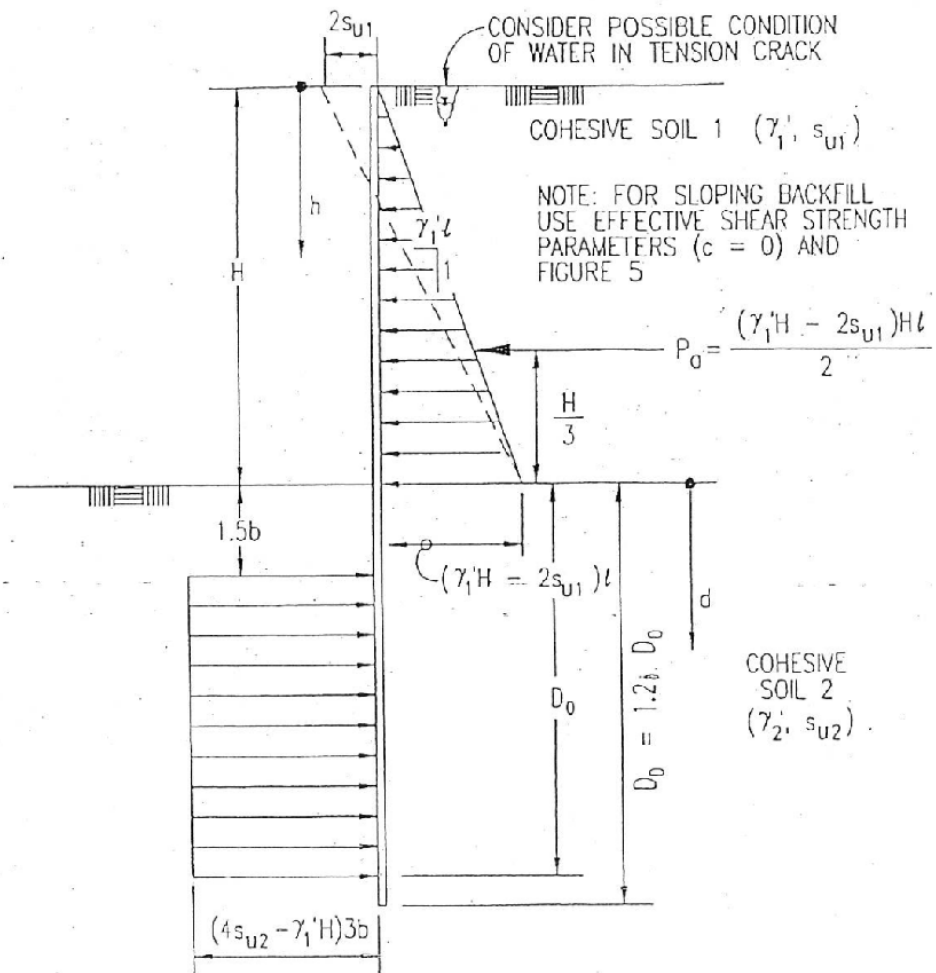

- l = CENTER TO CENTER SPACING OF DISCRETE VERTICAL WALL ELEMENTS
 b = WIDTH OF DISCRETE VERTICAL WALL ELEMENT

PRESSURE DISTRIBUTION

NOTE: SURCHARGE AND WATER PRESSURES MUST BE ADDED TO THE ABOVE EARTH PRESSURES.

SIMPLIFIED EARTH PRESSURE DISTRIBUTION FOR TEMPORARY FLEXIBLE WALLS WITH DISCRETE VERTICAL WALL ELEMENTS - RETAINING COHESIVE SOIL WITH EMBEDMENT IN COHESIVE SOIL

Greiner
 GREINER, INC.
 CONSULTING ARCHITECTS/ENGINEERS
 THUNDERBOLT, MARYLAND



BWI

MARYLAND DEPARTMENT OF TRANSPORTATION
 MARYLAND AVIATION ADMINISTRATION
 DIVISION OF ENGINEERING

BALTIMORE/WASHINGTON
 INTERNATIONAL AIRPORT

TITLE
 SIMPLIFIED EARTH PRESSURE
 DISTRIBUTION FOR TEMPORARY
 SUPPORT OF EXCAVATION

DATE
 JULY, 1995
 (REV. FEB. 1996)

FIGURE NO.
 7

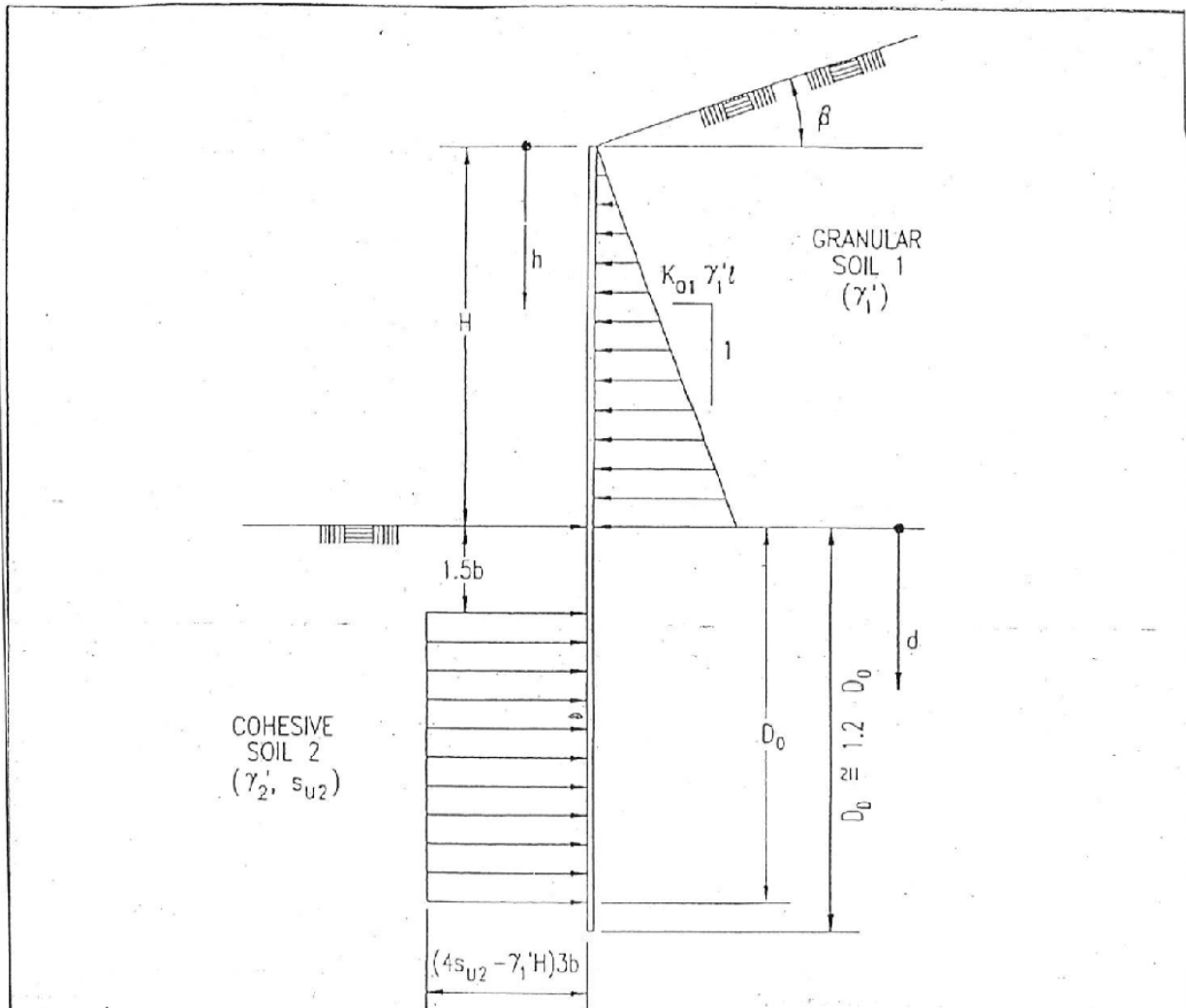

- l = CENTER TO CENTER SPACING OF DISCRETE VERTICAL WALL ELEMENTS
- b = WIDTH OF DISCRETE VERTICAL WALL ELEMENT

PRESSURE DISTRIBUTION

NOTE: SURCHARGE AND WATER PRESSURES MUST BE ADDED TO THE ABOVE EARTH PRESSURES.

SIMPLIFIED EARTH PRESSURE DISTRIBUTION FOR TEMPORARY FLEXIBLE WALLS
WITH DISCRETE VERTICAL WALL ELEMENTS – RETAINING GRANULAR
SOIL WITH EMBEDMENT IN COHESIVE SOIL

Greiner

GREINER, INC.
CONSULTING ARCHITECTS/ENGINEERS
INDROPS, MARYLAND



BWI

MARYLAND DEPARTMENT OF TRANSPORTATION
MARYLAND AVIATION ADMINISTRATION
OFFICE OF ENGINEERING

BALTIMORE/WASHINGTON
INTERNATIONAL AIRPORT

TITLE

SIMPLIFIED EARTH PRESSURE
DISTRIBUTION FOR TEMPORARY
SUPPORT OF EXCAVATION

DATE

JULY, 1995
(REV. FEB. 1996)

FIGURE NO.

8

SECTION 7 LIMITATIONS AND RESTRICTIONS

SP-7.01 Use of Explosives

The use, storage, or transportation of explosives will not be permitted on any contract, unless specified in the technical provisions.

SP-7.02 Recycled or Rehandled Materials

For recycled or rehandled material furnished on the project by the Contractor for use in embankment, surface, base course, base, subbase or drainage media, the Contractor is required to a) have the material tested and certified to be in conformance with all applicable environmental requirements, or b) furnish a certification of no contamination from the provider of the material. The required testing shall include, but not be limited to, all applicable State regulations, the US Environmental Protection Agency Toxicity Characteristic Leaching Procedure (TCLP) or its successor. The evaluation and interpretation of the test data will be made by the Engineer and be based on the project environment. Testing and certification shall be at the Contractor's expense.

SP-7.03 Night Work

No night work between the hours of sundown and sunrise will be permitted except with the written permission of the Engineer or unless specified in other parts of the Specifications or Contract Drawings.

SP-7.04 Saturday, Sunday, and Holiday Work

No work requiring the presence of the Engineer or Inspector will be permitted on Saturday, Sunday, or legal holidays designated as overtime holidays except when approved by the Engineer, in writing, forty-eight (48) hours in advance of the desired workday(s), or in cases of emergency and then only to such extent as is absolutely necessary.

SP-7.05 Parking of Vehicles and Construction Limitations

- A. The parking of private vehicles within the construction areas will not be permitted at any time. Construction vehicles, properly identified with the Contractor's name plate, will be allowed within the construction area when they are necessary to prosecute the work involved. If, in the determination of the Engineer certain construction vehicles are obstructing construction progress, he will request these vehicles to be moved and his decision will be final.

SP-7.06 Monitoring Well Permit

When required, elsewhere in the Contract Documents, the Contractor shall secure any monitoring well permits. Permits must be filed with the county in which the Contract is being performed.

- A. Anne Arundel County:
Department of Health, Division of Environmental Health,
3 Harry S. Truman Parkway, Annapolis, Maryland 21401
410-222-7389

- B. Baltimore County:
Department of Environmental Protection & Resource Management,
401 Bosley Avenue, County Court Building, Towson, Maryland 21204
410-887-2762

SECTION 8 EXECUTION AND PROGRESS

SP-8.00 Project Scheduling Requirements

- A. The Contractor shall develop project schedules fully conforming to the requirements of Special Provision: **SP-8.03**-Critical Path Method Schedules.
- B. The Contractor will develop and submit a project CPM schedule, consisting of Detailed Schedules #1, after issuance of a “Notice of Recommended Award” (NORA), as required in the Project CPM Development and Submission Table (“Table”) below. This schedule is subject to the review and acceptance process set forth in the Table and the times prescribed therein are of the essence.
- C. The Administration will execute the Contract and issue a "Notice to Proceed" (NTP) for the project only if the Administration accepts the Contractor's Detailed Schedules #1. If acceptance of the Detailed Schedules #1 or #2 occurs after the time specified in the Table due to late or nonconforming submissions by the Contractor, the Contract Performance Time specified elsewhere in the Contract shall be reduced by the number of days of delay in acceptance of Detailed Schedules #1 or #2 caused by late or nonconforming schedule submissions.
- D. For purposes of developing the project CPM schedule submissions in accordance with the Table, the Contractor shall use a Notice to Proceed date that is issued within one hundred and twenty (120) days after the “Notice of Recommended Award” date. Within seven (7) days after a “Notice to Proceed” is issued, the Contractor will resubmit the approved project CPM schedule incorporating the actual “Notice to Proceed” date and reflecting any adjustments to Contract Performance Time pursuant to paragraph C above.
- E. If any Detailed Schedule submission is late or, if the Administration determines that the Contractor will not reasonably complete the project within the reduced Contract Performance Time, in addition to any other remedies available to it, the Administration may terminate the Contractor’s right to proceed with the Contract for default pursuant to General Provision: **GP-8.08**-Termination for Default-Damages for Delay-Time Extensions. If the Contract is not executed for reasons unrelated to submission, review, and acceptance of the Project CPM Schedule, the Administration shall reimburse the Contractor its actual costs of developing the Project CPM Schedule.

Project CPM Schedule Development and Submission Table I:

Activity / Submission Description	Working* Days Due From NORA
Notice of Recommend Award (NORA) Issued	0
Contractor Designates Scheduling Representative	1
Schedule Requirements Review Meeting	3
Schedule Format Review Meeting	8
Contractor's Initial Detailed Schedule #1 Due	18
Contractor's Schedule Presentation to Engineer	20
Engineer's Review of Initial Detailed Schedule #1 Due	25
Contractors Final Detailed Schedule #1 Due	30
Engineer's Review of Final Detailed Schedule # 1 Due	35
Planned Acceptance of Detailed Schedule #1 (Required prior to issuance of NTP)	35

Project CPM Schedule Development and Submission Table II:

Activity / Submission Description	Working* Days Due From NTP
Contractor's Initial Detailed Schedule #2 Due	10
Engineer's Review of Initial Detailed Schedule #2 Due	15
Contractor's Final Detailed Schedule #2 Due	20
Engineer's Review of Final Detail Schedule #2 Due	25
Planned Acceptance of Detailed Schedule #2 (Required prior to 1 st Progress Payment)	25

*Based on five day work week

SP-8.01 Subcontracting

- A. Notwithstanding **GP-8.01**, the Contractor must submit, with Contract Forms, a "Subcontractor Utilization Form" for assignment or disposition of work under his/her Contract. A sample "Subcontractor Utilization Form" is included under Contract Forms, Section 7.
- B. In accordance with **GP-8.01**, Subcontracting, within fourteen days (14) after award of the Contract, the Contractor shall deliver to the Engineer a completed Statement of Acknowledgement Form for each subcontract. This form, signed and dated, acknowledges that all of the applicable Standard Provisions, indicating Volume and Date, and applicable Technical Provisions has been included in the subcontract.
- C. A sample "Subcontractor Statement of Acknowledgement Form" is included under Special Provisions, Section 10, **SP-10.03**, and in the Technical Provisions.
- D. Within fourteen (14) days after the award of any subsequently awarded subcontract, the Contractor shall deliver to the Engineer an updated form for each additional subcontract.

SP-8.02 Schedules

- A. The Contractor shall submit, within thirty (30) days from the date of the Notice-to-Proceed, a progress schedule in accordance with Section **GP-8.04**, Progress Schedule. This schedule shall be updated and revised to reflect all changes affecting the job progress. The prosecution of the work shall always be under the direction of the Engineer. The Contractor shall work at as many different points, in such part or parts, and at such times as may be directed.
- B. If in the opinion of the Engineer, an immediate need exists for a schedule of submittal and construction activities, the Contractor shall prepare for review and approval an interim schedule for the first sixty (60) days of operation. The interim schedule will be required to be submitted in accordance with all requirements of this section and of **GP-8.04**, Progress Schedule.
- C. The work schedule to be submitted by the Contractor, as provided in the subsection of the **GP-8.04**, Progress Schedule, shall be so prepared and the proposed work shall be so conducted as to interfere as little as possible with other construction work, and vehicular traffic. The schedule shall be satisfactory to the Engineer. The Contractor shall submit a schedule based on area sequencing and phasing as well as by construction elements. The Engineer may withhold all monies due, or to become due, the Contractor for partial payments until a work schedule is received and approved by the Engineer.
- D. The progress schedule shall graphically indicate by the use of bars, lines, or other conventional methods, phasing of all work and related operations. The Contractor

shall show, thereon, dates and the number of days proposed to complete the major operations involved in this Contract. He/she shall also show the relationship of working days to total earnings. The schedule shall also include dates when Shop Drawings and related Working Drawings as well as informational data shall be required under the various headings of the Specifications to be submitted to the Engineer for approval. The schedule shall provide adequate time for review and approval with the entire submittal procedure coordinated through the Engineer. The schedule shall be updated and revised on a regular basis incorporating any changes and shall reflect any delays or escalation affecting job progress.

- E. During the progress of the work, it may be necessary for the Engineer to adjust the approved schedule to better suit Airport Operations. In addition, other contracts may be under construction concurrently with this Contract, and the Contractor shall coordinate his/her work as required in **GP-5.06**, Cooperation Between Contractors. The Contractor shall cooperate fully with the Engineer and user agencies in the programming of his/her work to insure the uninterrupted functioning of services essential to the operation of the Airport and the maintenance of security measures.
- F. When specified in the Technical Provisions, the Contractor shall develop Critical Path Method Schedules (CPM) in accordance with the requirements set forth under Special Provisions, Section **SP-8.03**, Critical Path Method Schedules.

SP-8.03 Critical Path Method Schedules

A. General:

The requirements for the Critical Path Method Schedule included in this section shall supersede General Provision: **GP-8.04**-Progress Schedules.

1. Careful evaluation and pricing of the schedule provisions of this Contract are important to assure compliance with the language and intent of the schedule specification. The schedule provisions are designed to provide the Contractor and the Administration with a tool for planning and controlling the work. The schedule provisions must be strictly followed to insure both timely progress payments and equitable compensation for changes and delays. The Contractor must perform work in accordance with the approved Critical Path Method (CPM) Schedule to achieve timely completion of all Contract milestones and to avoid acceleration, termination for default, and end of Contract claims for liquidated damages. The Contractor must give the schedule provisions particular consideration and resolve any areas of uncertainty by asking appropriate questions prior to bid opening.

The schedule submission times shall be as specified in the "Project CPM Development and Submission Table" included in the solicitation documents under section **SP-8.00**-Project Scheduling Requirements.

2. The Contractor shall provide CPM schedules as defined in the following criteria.
- a. The purpose of the Project Schedule shall be to:
- (1) Assure adequate planning, scheduling and reporting during execution of the work by the Contractor;
 - (2) When more than one Prime Contractor is working at a site, assure coordination of the work of the Contractor and the various subcontractors and suppliers at all tiers;
 - (3) Assist the Contractor and Engineer in monitoring the progress of the work and evaluating proposed changes to the Contract and the Project Schedule;
 - (4) Assist the Engineer and the Contractor in the preparation and evaluation of the Contractor's monthly progress payments;
 - (5) Provide information to the Engineer enabling the timely coordination of work activities involving Tenants and/or impacting Airport or Tenant operations; and
 - (6) Assist the Engineer in determining required dates for owner supplied materials and services.
- b. The Project Schedule shall employ the CPM using retained logic for the planning, scheduling and reporting of the work to be performed under the Contract. Start and finish dates in the schedule shall be calculated by schedule logic and activity durations, not by resources or non-contractual constraints. All activity codes and calendars used shall be project-level. The schedule will be produced utilizing the most current version of Primavera P6 software system, or fully transferable to P6 (refer to "Products (Scheduling Software)" in Section K of this Provision). Definitions applicable to this Provision include the following:
- (1) Project Schedule: The Project Schedule includes the electronic XER file;
 - (2) Critical Path: The Critical Path is the sequence of the activities in the Project Schedule network which requires the longest total amount of time to complete the work or any path(s) which have total float less than one (1) working day;
 - (3) Time Scale Logic Diagram: The Time Scale Logic Diagram (TSLD) is the graphic representation of the Project Schedule prepared as an 11" x 17" electronic (.PDF) format using the CPM. The TSLD shows the sequence and interdependence of the activities, and planned and actual

progress by activity, required for complete performance of the work. The columns shown shall include the activity ID, activity description, original duration, remaining duration, early start and finish, late start and finish, actual start and finish, and total float, or as requested by the Engineer;

(4) Working Day: A working day is any calendar day scheduled for active performance of Contract requirements; and

(5) Key Plans: Graphic representations of the Contractor's planned breakdown of the project for scheduling purposes. The key plans will clearly define the boundaries of the work for each designated area. The boundaries of each area may change depending on the phase of construction. The alphanumeric codes on the key plans shall match the code values for the "Area" in the schedule.

- c. The Contractor shall provide Time Scale Logic Diagrams as stipulated herein, at no additional cost to the Administration.
- d. The Contractor shall meet with the Engineer per the Project CPM Development and Submission Table to conduct a joint review of the Project Schedule requirements of the Contract to assure the Administration of the Contractor and subcontractor's understanding of the requirements of this Section. Refer to "Schedule Approval Process" under this item.
- e. Per the Project CPM Development and Submission Table, there will be a formal presentation by the Contractor of its intended prosecution of the project. The Contractor's Management Team and Scheduling Representative shall conduct the formal presentation utilizing schedule graphics and charts of the approach the Contractor will take to complete the project within the contractual milestones. The Contractor shall provide electronic (.PDF) format of the proposed key plans of the project and each structure for each phase throughout the duration of the project. The Contractor shall also provide proposed codes and code values of activities for the project. The key plans and coding descriptions shall match exactly.

3. Contractor's Scheduling Representative:

- a. Per the Project CPM Development and Submission Table, the Contractor shall designate in writing an authorized representative in the Contractor's organization (Scheduling Representative) who shall be responsible for preparation and maintenance of the Project Schedule. The Contractor may not replace the Scheduling Representative without prior written consent of the Engineer,
- b. The Contractor shall submit the qualifications of the Scheduling Representative to the Engineer for approval. The approval is required

before the Detailed Schedule #1 will be accepted. The Scheduling Representative shall have at least five years of verifiable experience for preparing and maintaining CPM project schedules in Primavera P6 on contracts of similar size and complexity.

- c. The Scheduling Representative shall have complete authority to act on behalf of the Contractor in fulfilling the Project Schedule requirements of the Contract and such authority shall not be interrupted throughout the duration of the Contract unless approved in writing by the Engineer.
- d. The Scheduling Representative shall attend all schedule-related meetings and all monthly update meetings throughout the duration of the Contract in addition to the General Superintendent.
- e. The Contractor agrees that whenever the Engineer advises the Contractor in writing that the Scheduling Representative is not performing his/her duties to the satisfaction of the Administration, the Contractor shall replace the Scheduling Representative at no additional cost to the Administration and designate in writing, within seven (7) calendar days, a new authorized representative satisfactory to the Engineer.

4. Schedule Requirements review Meeting

At the Schedule Requirements Review Meeting, the Engineer will review in detail the scheduling requirements contained in the specifications.

5. Schedule Format Review Meeting

At the Schedule Format Review Meeting, the Contractor will present to the Engineer the Format of the schedule developed to that point. Format includes: Activity Coding Structure, calendars, prototype activity descriptions, logic and graphical presentations.

B. **Detailed Schedule #1:**

1. Per the Project CPM Development and Submission Table I, the Contractor shall submit a Detailed Schedule #1 showing all work to be accomplished on the project. Detailed Schedule #1 shall include, but not be limited to, the following:

- a. Procurement activities:

The proposed procurement activities shall include mobilization, shop drawings and sample submittals, fabrication and delivery of key and long-lead procurement elements. The schedule shall indicate intended submittal dates and realistic delivery dates for fabrication and delivery activities.

- (1) The Administration's review of: shop drawings, product data, samples and requested substitutions shall be identified as schedule activities. The minimum duration for these activities shall be twenty-one (21) calendar days for shop drawings, product data and samples and forty-five (45) calendar days for requested substitutions in accordance with Special Provisions: **SP-8.06**-Submittals (Shop Drawings, Product Data and Samples) and **SP-5.04**-Request For Substitutions.
 - (2) In the event a submittal is rejected or returned for correction, a new activity will be inserted into the schedule for Resubmission and another for Review of the Resubmission.
- b. Construction activities:
- (1) The construction activities shall cover all physical work activities performed by the Contractor and subcontractors.
 - (2) The construction activities shall also cover all work to be performed by the Administration or its contractors related to the Contract.
- c. Milestone events as required by the Contract Documents.
- d. Commissioning activities, as separate activities, shall show:
- (1) All training activities required by the contract prior to project or phase substantial completion; and
 - (2) All testing activities required by the contract prior to project or phase substantial completion.
2. The Time Scale Logic Diagram (TSLD) shall show the sequence and interdependence of activities required for complete performance of the work. The Contractor shall be responsible for assuring all work sequences are logical and the TSLD shows a coordinated plan of the work.
 3. The time duration assigned to each activity shall be the Contractor's best estimate of working days required to complete the activity considering the scope and resources planned for the activity and shall be limited to a maximum of fifteen (15) working days for each activity. The minimum time duration shall be one (1) working day.
 4. Anticipated lost time due to weather shall be included in the Schedule to ensure completion of all work within the Contract time. These days will be eliminated from the Schedule's work calendar and spread over each month. The days eliminated may not coincide with holidays or other days that would already be non-workdays. Individual activity durations are not to be increased to include

- expected lost weather days. Special Provision: **SP-8.10**-Time Extensions for Unusually Severe Weather, sets out the maximum number of days expected to be lost assuming a five day work week. Time extensions for abnormal weather will only be granted when the actual lost days exceed the maximum number, and are not compensable. The Contractor's incorporation of the anticipated lost weather days must be acceptable to the Engineer. Time extensions for unusually severe weather beyond the contractual completion date will not be granted if the contract duration has extended beyond the contractual completion date due to contractor delay.
5. Restrictions on all temperature-sensitive construction activities shall be included in the Schedule. The Contractor's incorporation of these restrictions into the schedule must be acceptable to the Engineer.
 6. In developing the Schedule, the Contractor shall be responsible for assuring that subcontractor and supplier work at all tiers, as well as its own work, is included in the Schedule.
 7. The following shall be depicted on the Network for each activity:
 - a. Concise description of the work represented by the activity (maximum 120 characters). The work related to each activity shall be limited to one work trade and one floor or other building as required by the Specifications. Activity descriptions shall include verbs and shall quantify the work where possible;
 - b. Activity duration in whole working days with a minimum duration of one (1) workday and a maximum duration of fifteen (15) workdays each, unless otherwise approved or directed by the Engineer, except for non-construction activities including mobilization, shop drawing and sample submittal, fabrication of materials, delivery of materials and equipment and concrete curing;
 - c. Work area project-level activity code for construction activities (maximum 20 characters). All abbreviations shall be fully described in a legend attached to the Time Scale Logic Diagram. As requested by the Engineer, either prior or subsequent to the acceptance of the Schedule, the Contractor shall provide, without additional cost to the Administration, a graphic illustration of the relationship of construction activities to intended work areas as identified by the Contractor on prints of the Contract Drawings;
 - d. Performance responsibility by discipline project-level activity code: MECH, ELEC, etc., or other acceptable abbreviations approved by the Engineer (maximum of 20 characters). Each subcontractor shall be coded separately. Include activity code values for MBE and non-MBE subcontractors. All

abbreviations shall be fully described in a legend attached to the Time Scale Logic Diagram;

- e. A project-level activity code that shall identify the specification number appropriate to the activity.
- f. A project-level activity code that shall identify the phase of the project in which the activity is to be performed.
- g. A project-level activity code that differentiates between submittal/procurement activities and construction activities.
- h. Each submission of Detailed Schedule #1 shall include:
 - (1) All schedule information in electronic (.XER) format as directed by the Engineer.
 - (2) An electronic (.PDF) file format of its proposed Detailed Network (Time Scale Logic Diagram) sorted by Early Start of all activities.
 - (3) A written Narrative that shall present the construction approaches and explains the schedule logic. It shall discuss the project's critical path. It shall state how the Contractor plans to work the project (days/shifts/hours). It shall give the expected number of lost working days to weather for each month and discuss how the Schedule calendar accounts for these lost days. It shall present any temperature restrictions included in the schedule.
- i. If the Engineer questions the Contractor's proposed activities, logic, or durations, the Contractor shall provide a satisfactory revision, or adequate justification, to the satisfaction of the Engineer.
- j. Failure by the Contractor to include any element of work required for performance of the Contract shall not excuse the Contractor from completing all work within the Contract time.
- k. The approved Detailed Schedule #1 shall become the baseline project schedule for logic and durations.
- l. Detailed Schedule #1 shall have a data date of the Notice of Recommended Award, or as directed by the Engineer.

C. Detailed Schedule #2:

- 1. Per the Project CPM Development and Submission Table II, the Contractor will

submit Detailed Schedule #2 which shall include all appropriate cost, manpower, and if specifically requested, major equipment requirements for the schedule activities. Detailed Schedule #2 shall utilize the approved Detailed Schedule #1 as the base schedule and add resource and cost loading as detailed below.

2. Detailed Schedule #2 shall use the same state date as Detailed Schedule #1 and shall incorporate the actual Notice to Proceed date into the schedule.
3. The following shall be incorporated into the Network for each construction and appropriate procurement activity:
 - a. For Lump Sum contracts, the assigned dollar value of each activity in the Network, shall represent its labor, material and equipment costs. Activity cost estimates shall correlate with, the breakdown of the total Contract price as shown in the Detailed Schedule of Values (**See Part I, General Information Section of Plans & Specifications**). Each subcontractor's overhead and profit, mobilization and demobilization, bond and insurance costs shall be allocated between its activity costs (labor and materials). The total for all activities representing work for a given specification section shall cumulatively equal the sum of the labor and material amounts shown for that specification section in the Detailed Schedule of Values. The General Contractor's general conditions, overhead and profit, mobilization and demobilization, quality control program, bond and insurance costs shall not be included in the activity costs but shall be shown as separate Level of Effort activities in the Schedule and conform to the approved Detailed Schedule of Values.
 - b. For unit price contracts, or for unit price activities of an otherwise Lump Sum contract, the assigned value of each activity shall represent the expected costs (covering labor, material and equipment) based on the expected quantity of material estimated for the activity and its quoted unit price. The activity's quantity shall be shown on the Network and shall also be included in the activity's description. Project mobilization, bond, insurance costs, overhead and profit shall not be included in the activity costs nor separately in the Network (and shown separately in the Schedule of Values).
 - c. The manpower loading of each activity in the Network, for a fixed or unit price contract, shall be the total number of man hours of each activity. For a fixed price contract, the total number of man hours assigned to the Network shall correlate with the labor costs in the Schedule of Values for each subcontractor's work.
 - d. For cost loading purposes, fabrication activities will not be cost loaded but delivery activities may be.

3. Each submission of Detailed Schedule #2 shall include:
 - a. All schedule information in electronic (.XER) file format as directed by the Engineer.
 - b. An electronic (.PDF) file format of its proposed Time Scale Logic Diagram sorted by Early Start of all activities.
 - c. A written Narrative presenting the cost, manpower and equipment information in summary form and discussing any anticipated problems with attainment of the required levels.

D. Engineer Reviews, Joint Reviews, Revisions and Acceptance:

1. The Engineer will review the initial submissions of the Detailed Schedule #1 and Detailed Schedule #2 and will respond with comments in accordance with the Project CPM Development and Submission Table. The Engineer and the Contractor shall meet in accordance with the Project CPM Development and Submission Tables for joint review, correction or adjustment of the Detailed Schedule #1 and #2. Any areas which, in the opinion of the Engineer, conflict with timely completion of the Contract shall be subject to revision by the Contractor.
2. In the event the Contractor fails to define any element of work, activity, or logic and the Engineer's review does not detect this omission or error, such omission or error, when discovered by the Contractor or the Engineer, shall be corrected by the Contractor at the next monthly Schedule Update (as discussed hereinafter) and shall not affect the Contract time.
3. As required by the Project CPM Development and Submission Tables, the Contractor shall revise the Schedule in accordance with agreements reached during the joint review meetings and submit in electronic file format as directed by the Engineer.
4. In the event that Detailed Schedule #1 indicates the Contractor's plan to finish prior to the Contract completion date, the Contractor and the Administration shall execute a change order adjusting the Contract completion date to coincide with the Contractor's planned finish date at no expense to the Administration. Liquidated Damages will be measured from the adjusted Contract completion date.
5. Acceptance by the Engineer of the Contractor's approved Project Schedule will be a condition precedent to issuance of a Notice to Proceed, and the making of any progress payments under the Contract.

6. Upon acceptance of the Project Schedule by the Engineer, the cost-loaded values of the Project Schedule will be used as a basis for determining progress payments. Monthly progress payments shall be based upon information developed in the monthly Schedule Update. The computer-produced Cost Report will be utilized by the Engineer for verification of the Application for Payment submitted by the Contractor. Acceptance by the Engineer of the Contractor's Project Schedule does not relieve the Contractor of any responsibility whatsoever for the accuracy or feasibility of the Project Schedule, or of the Contractor's ability to meet the Contract Completion Date. Nor does such acceptance create a warranty, expressed or implied, or acknowledge or admit the reasonableness of the activities, logic, durations, manpower, cost of equipment loading of the Contractor's Project Schedule.

E. Project Schedule Updating:

1. The Project Schedule shall be updated on a monthly basis throughout the entire Contract time and until the Contract's Substantial Completion. The Contractor shall meet with the Engineer each month at the Schedule Update meeting to review actual progress made through the data date of the Schedule Update, including dates activities started and/or completed, and to discuss the scheduling of future work. Revisions to the Network logic to more accurately reflect the anticipated workflow can be discussed and mutually agreed-to, as well as changes to activity durations, staffing and equipment. The data date of each Schedule Update, which shall be the effective date of the Progress Payment Request, shall be on or before the seventh (7th) day preceding the progress payment submittal deadline. Contractor-prepared estimates of the percent completion of each schedule activity and the necessary supporting cost data shall be presented at the update meeting and shall include the following information:
 - a. The previous month's Schedule Update in both electronic (.XER) file format and electronic (.PDF) file format updated to indicate the progress on schedule activities and the revised (current) remaining durations.
 - b. The previous month's Schedule Update must indicate actual activity start and/or complete dates, revised (current) remaining durations, and percent complete with regard to activity cost/progress.
 - c. A listing of proposed activities to be added together with predecessors and successors, duration, manpower and cost.
 - d. A listing of proposed activities to be deleted.
 - e. Any additional written information necessary to support the above.

2. In case of disagreements at the schedule update meeting, concerning actual progress to date, the Engineer's determination shall govern.
3. Upon completion of the schedule update meeting, the Contractor shall revise the Project Schedule to reflect progress as of the data date of the Schedule Update and carry out a computer-produced calculation to determine the status of the Project Schedule. This progress only schedule will be considered the A-Schedule. The Contractor shall use the A-Schedule and make any required revisions to the Project Schedule and carry out a computer-produced calculation to determine the status of the Project Schedule. This revised schedule will be considered the B-Schedule. The Contractor shall process the A and B-Schedules. The Contractor shall process the A and B Schedules within three (3) calendar days and forward the update and pay request to the Engineer. The Engineer shall review the update upon receipt, and shall process the monthly request for payment based upon the accepted update.
4. Each Project Schedule Update, based upon the Contractor's input as discussed above, will be forwarded to the Engineer and will include the following information:
 - a. A written Narrative summarizing schedule status and providing the following detailed information:
 - (1) A listing and explanation of activities added and deleted.
 - (2) A listing and explanation of logic changes (overlapping, etc.)
 - (3) A comparison of actual manning and equipment usage to the requirements of the previous update.
 - (4) A discussion of possible recovery actions to counter any schedule slippage. In the event that schedule slippage exceeds twenty-one (21) calendar days, this portion of the Narrative will be comprehensive. If it is not, then the Engineer may reject the schedule update and delay processing of the monthly Pay Request.
 - b. The latest schedule update, including the separate A and B-Schedules, in electronic file format as directed by the Engineer.
 - c. An electronic (.PDF) file format of the current Network (Time Scale Logic Diagram) sorted by Early Start of all activities.
 - d. The monthly updating of the Project Schedule shall be an integral part and basic element of the estimate upon which progress payments will be made. If, in the judgment of the Engineer, the Contractor fails or refuses to provide information required to accomplish a complete Project Schedule Update or

revision as specified hereafter, the Contractor shall be deemed to have not provided the required estimate upon which progress payments may be made, and shall not be entitled to progress payments until it has furnished the information necessary for a complete Schedule Update to the satisfaction of the Engineer.

F. Project Schedule Revisions:

1. Updating the Project Schedule to reflect actual progress made up to the date of a Schedule Update shall not be considered a revision to the Project Schedule.
2. The Contractor may also request revisions to the Project Schedule in the event the Contractor's planning of the work is revised. If the Contractor desires to make changes in the Project Schedule to reflect revisions in its method of performing the work, the Contractor shall notify the Engineer in writing at least seven (7) calendar days prior to the next Schedule Update meeting, stating the reason for, and describing, the proposed revisions. Accepted revisions will be incorporated into the Project Schedule at the next monthly Schedule Update.
3. If the Engineer believes that the Project Schedule needs a specific revision, either in logic, activity duration, manpower or cost, it will be requested from the Contractor in writing. The Contractor shall respond in writing within seven (7) calendar days, either agreeing with the Engineer's proposed revision, and henceforth including it in the next Project Schedule Update, or setting forth justification why it should not be accomplished. If the Contractor's justification for not accomplishing the revision is accepted, such revision will not be incorporated into the next update of the Project Schedule. The Contractor's failure to respond in writing within seven (7) calendar days will be deemed to be an acceptance of the Engineer-requested revision, and such revision shall be incorporated into the next Project Schedule update.

G. Recovery Schedule

1. If, as a result of the Project Schedule Update, it appears that the Project Schedule as shown no longer allows attainment of the Project completion date, the Engineer will request, and the Contractor shall submit, a recovery schedule sufficiently explaining, detailing, and displaying to the Engineer's satisfaction, how the Contractor intends to reschedule its work in order to regain the contractual requirements, all without additional cost to the Administration. This may require the Contractor to increase the number of shifts, initiate or increase overtime operations, increase days of work in the work week, or all of them.
2. The Engineer shall make his request in writing within five (5) calendar days of receiving the monthly update. The Contractor shall submit this recovery schedule at least five (5) calendar days before the next scheduled update

meeting so that the Engineer may review and accept it for use in the next schedule update.

H. **Time Impact Analysis for Proposed Change Orders and Delays:**

1. When the Contractor desires to obtain an extension of the project duration because of a change order or other occurrence on the project, the Contractor shall submit to the Engineer a written Time Impact Analysis illustrating the influence of the change order or occurrence on the Contract Schedule. Each Time Impact Analysis shall include a Fragmentary Network (FragNet) demonstrating how the Contractor proposes to incorporate the change order or occurrence into the Project Schedule. The Time Impact Analysis shall demonstrate the time impact based on the date the change order was given to the Contractor or the date of the occurrence; the status of construction at that point in time; and the event time computation of all affected activities. Upon approval by the Engineer, the change order or occurrence shall be included in the next Project Schedule update.
2. Activity delays shall not automatically mean that an extension of the Contract time is warranted or due the Contractor. It is possible that a change order or occurrence will not affect existing critical activities or cause non-critical activities to become critical. A change order or occurrence may result in only absorbing a part of the available total float that may exist within an activity chain of the Network, thereby not causing any effect on the Contract time.
3. Float is not for the exclusive use or benefit of either the Administration or the Contractor. Extension of the Contract time will be granted only to the extent the equitable time adjustments to the activity or activities affected by the change order or occurrence exceeds the total float of a critical activity (or path) and extends the Contract time set forth in the General Provisions: **GP-8.03-Prosecution of the Work**, and **GP-8.09-Liquidated Damages**.
4. Submit Time Impact Analysis in accordance with the following along with a written proposal for any requested time extension;
 - a. Within seven (7) calendar days after receipt of a written change order pursuant to General Provision: **GP-4.06-Changes** and Special Provision: **SP-9.04-Negotiated Payment**.
 - b. Within ten (10) calendar days from the beginning of a delay from unforeseeable causes pursuant to General Provisions: **GP-4.05-Differing Site Conditions**, **GP-8.07-Suspension of Work**, and/or **GP-8.08-Termination for Default-Damages for Delay-Time Extensions**.
 - c. With the filing of a written notice of claim pursuant to General Provision: **GP-5.14-Claims**.

5. In cases where the Contractor does not submit a Time Impact Analysis within the time requirements stated above, it shall be considered a waiver of any request for an extension of the Contract Performance Time. Any subsequent Time Impact Analysis submitted by the Contractor shall be dismissed by the Procurement Officer as untimely.
6. Approval or rejection of each Time Impact Analysis by the Engineer shall be made within seven (7) calendar days after receipt of each Time Impact Analysis, unless subsequent meetings and negotiations are necessary. Upon approval, a copy of the Time Impact Analysis signed by the Engineer shall be returned to the Contractor, and incorporated into the next Project Schedule Update.
7. The Time Impact Analysis related to a change order shall be incorporated into and attached to the applicable change order.

I. **Responsibility for Completion:**

1. The Contractor shall furnish sufficient forces, offices, facilities and equipment, and shall work such hours including night shift and overtime operations, as necessary to ensure the prosecution of the work in accordance with the current monthly Project Schedule Update. If the Contractor falls behind in meeting the Project Schedule as denoted by negative float in the current monthly Project Schedule Update, at the direction of the Engineer, the Contractor shall take such steps as may be necessary to improve its progress. Determining the justification of additional payment to the Contractor for such actions shall not be a precursor for these actions. The provision of this paragraph shall not be construed as prohibiting the Contractor from increasing the hours of work, the number of shifts, overtime operations and/or the amount of construction plant and equipment or working on Saturdays, Sundays and holidays, provided the Contractor gives reasonable notice to the Engineer as required under Special Provisions: **SP-7.03-Night Work** and **SP-7.04-Saturday, Sunday, and Holiday Work**.
2. Failure of the Contractor to comply with the requirements of paragraph H.1 above shall be a basis for determination by the Engineer that the Contractor is not prosecuting the work with such diligence as will ensure completion within the Contract time. Upon such determination, the Engineer may terminate the Contractor's right to proceed with the work or any separable part thereof, in accordance with the General Provision: **GP-8.08-Termination for Default, Damages for Delay - Time Extensions**, or may take such other actions as may be deemed appropriate.

J. Performance Monitoring:

1. The Engineer may elect throughout, or at any time, during the Contract to record the number of workers and construction equipment working on each schedule activity in each area of the Contract and give a copy of this log to the Contractor who shall be responsible for advising the Engineer, without additional cost to the Administration, of any error in this work history, in writing, within seven (7) calendar days of receipt of same. This information will be used by the Engineer in its evaluation of the adequacy of the Contractor's performance and on-site manpower staffing, as well as in the evaluation of any Contractor requests for additional payment.
2. For certain critical work, the Engineer may require that the Contractor submit each Monday morning (or following day if a holiday), a Status Report of all progress which has occurred in any schedule activity, including:
 - a. Percent Complete; and
 - b. Actual Start/Finish Dates.
3. This Status Report shall also indicate which activities the Contractor plans to start, or to continue during that week. This Status Report shall serve as a basis for discussion at the next project progress meeting. These actual start and finish dates and percentages of completion estimates will be used by the Engineer to evaluate the monthly Project Schedule Update.

K. Completion Schedule:

1. No later than sixty (60) days prior to the scheduled completion of the Project, the Contractor shall prepare and submit a detailed Completion Schedule to the Engineer for approval. This Completion Schedule shall indicate all remaining work under the Contract, grouped by designated areas, and shall be derived from the most recent monthly Project Schedule Update.
 - a. The designated areas for reporting shall be determined by the Engineer and shall be as detailed as may be required by the Engineer to facilitate coordination with the tenants, final testing, final inspections, and acceptance of the facility for maintenance pursuant to General Provision: **GP-5.13**-Acceptance for Maintenance and Special Provision: **SP-8.09**-Project Completion and Punchlist.
 - b. The Completion schedule shall be in the form of a computer-generated listing, which shall include every activity with work remaining in each designated area. Each activity listed shall only represent work by one trade/subcontractor. Estimated remaining manhours shall be shown for each activity listed.

2. The Contractor shall submit the Completion Schedule together with a written narrative that summarizes the manhours of effort required for completion of the project, itemized by the Contractor's work force and each subcontractor's work force. The narrative shall also include projections of the expected manning for each of the remaining weeks of the project, itemized by the Contractor's work force and each subcontractor's work force.
3. The Completion Schedule shall be updated by the Contractor at the end of each week to reflect actual progress and submitted to the Engineer on Tuesday of the following week together with new totals of remaining work and any revisions to the remaining week's expected manning.

L. Products (Scheduling Software):

The scheduling software used by the Contractor shall be fully capable of importing/exporting data to/from Primavera P6, latest version. The proposed software shall be capable of transferring the information without degradation in the data, including but not limited to, scheduling logic and sequencing, activities, durations, resource loading, etc. The electronic file shall be submitted in .XER format.

SP-8.04 Progress Meetings

- A. The Contractor shall attend weekly progress meetings with the Engineer. The meetings shall be attended by the Contractor's key project personnel. The overall status of the Contract shall be reviewed with particular attention to planned activities with special emphasis toward planned interruptions to existing utilities or services.
- B. The Contractor shall prepare for each meeting a bar chart construction schedule depicting the work accomplished the previous week and planned activities for the upcoming two week period. This schedule shall be derived from the most recent statused progress schedule. Any deviations from this planned schedule shall be documented in writing and immediately brought to the attention of the Engineer. All deviations from this planned schedule shall be subject to the Engineer's review and approval.

SP-8.05 Construction Quality Control Plan

- A. It shall be the responsibility of the Contractor to provide and maintain a Construction Quality Control Plan (hereinafter referred to as CQC Plan) for all work performed under the Contract. This requirement is in addition to any acceptance inspection and testing performed by the Engineer and/or his testing agencies. The CQC Plan shall conform to the requirements of this Special Provision. Within ten (10) days after issuance of the "Notice to Proceed" for the Contract, the Contractor shall submit an "Interim" CQC Plan to the Engineer for approval. The interim plan

shall cover all work to be performed under the Contract during the first sixty (60) days of work. Further, within thirty (30) days after issuance of the "Notice to Proceed", the Contractor shall submit a "Detailed" CQC Plan to the Engineer for approval. The detailed plan shall cover all work to be performed under the Contract. The Contractor's work may be suspended and progress payments may be withheld if the Contractor fails to submit conforming CQC Plans as scheduled herein.

- B. In addition to the requirements detailed in this Special Provision, the CQC Plan shall incorporate all inspection and testing requirements detailed in the Technical Specifications for the Contract. The CQC Plan shall encompass all actions involving selection of construction material sources and suppliers, on-site and off-site fabrication of the Contractor-furnished items to be included in the work, on-site and off-site production of construction materials, work placement procedures, workmanship, inspection, and testing. The CQC Plan shall be designed and administered to assure that the Contractor's work, including work performed by the Contractor's suppliers and subcontractors, will be in full compliance with all applicable codes, technical specifications and plans under the Contract with respect to materials, workmanship, construction, finish, functional performance and identification.
- C. With its Interim CQC Plan submission, the Contractor shall identify a qualified individual who shall be responsible for overall development and administration of the CQC Plan (CQC Plan Manager) and shall submit the proposed CQC Plan Manager's qualifications to the Engineer for approval. The CQC Plan Manager shall report directly to an executive officer of the Contractor's Company and shall have the necessary authority to discharge his/her responsibilities. The CQC Plan Manager shall visit the project site on a regular basis to assure proper administration of the CQC Plan. Depending on the nature and complexity of the work to be performed under the Contract and/or instances of non-conforming work, the Engineer may require the CQC Plan Manager to be on the project site on a full-time basis. For contracts in the amount of five million dollars (\$5,000,000) or above, the CQC Plan Manager shall be on the project site on a full-time basis throughout the duration of the Contract, and shall have no other responsibilities than those required by this Special Provision.
- D. With its Interim CQC Plan submission, the Contractor shall identify qualified individuals and firms responsible for inspection and testing of the work (CQC Plan Staff) and shall submit qualifications of the proposed CQC Plan Staff to the Engineer for approval. The CQC Plan staff shall be sufficient to inspect and test all items of work under the Contract as specified by this Special Provision. Members of the CQC Staff shall report directly to the CQC Plan Manager and shall have the necessary authority to discharge their responsibilities. For contracts in the amount of five million dollars (\$5,000,000) or above, members of the CQC Plan Staff shall be on the project site on a full-time basis throughout the duration of the Contract, and shall have no other responsibilities than those required by this

Special Provision. Further, for contracts in the amount of five million dollars (\$5,000,000) or above, the CQC Plan Staff shall include qualified, dedicated, full-time inspectors, in addition to appropriate testing personnel, for each major work discipline performed under the Contract. These major work disciplines include, but are not limited to, civil, structural, structural steel, mechanical, electrical, and specialty work.

- E. The Contractor's Interim CQC Plan submission must include as a minimum the following:
1. An organization chart showing the portion of the Contractor's corporate organization that is concerned with the on-site construction activities;
 2. The Contractor's on-site organization chart including its quality control organization;
 3. Proposed personnel (CQC Plan Manager and CQC Staff) to be used in the quality control organization, personnel qualifications and experience, and the planned duration of their services;
 4. Authority, duties and responsibilities of quality control personnel;
 5. Operational procedures for accomplishing and reviewing work, supervision, inspections, tests, construction material production controls, fabrication controls, certifications, documentation of quality control operations, and inspections and tests, including those for subcontractors. These procedures shall include the methods to be utilized during the procurement cycle (order to delivery) for those items of materials or equipment which require source inspection, shop fabrication, and operations away from the work site;
 6. Methods and procedures for selecting suppliers;
 7. Methods and procedures for indoctrination and instruction of quality control personnel, construction supervisors, and foremen;
 8. A copy of the letter of direction to the Contractor's representative and its staff for quality control which defines their delegated duties and responsibilities; and
 9. When the quality control functions are to be accomplished by personnel not located at the site and/or not directly under the control of the CQC Plan Manager, the on-site/off-site coordinating procedures and authorities shall be covered in detail in the CQC Plan.
 10. A detailed test and inspection plan keyed to the technical specifications, covering the work to be performed during the first sixty (60) days of work.
- F. The Contractor's Detailed CQC Plan submission shall include a detailed test and

inspection schedule, keyed to the Technical Specifications, for each item of work. The test and inspection schedule shall cover all work to be performed under the Contract, including both on-site and off-site fabrication. The CQC Plan shall include as a minimum at least three (3) phases of inspection to be performed by the CQC Staff for all distinct items of work, as follows:

1. Preparatory inspections shall be performed prior to beginning each item of work. Preparatory inspections shall include a detailed review of Contract requirements and the CQC Plan test and inspection schedule for the item of work with the: Engineer, CQC Staff, Contractor's Superintendent and subcontractor performing the work. Work shall not be permitted to proceed for any item of work that does not have an approved test and inspection schedule. Preparatory inspections shall also include: a check to assure that all materials and/or equipment have been tested, submitted, and approved; a check to assure that provisions have been made to provide required quality control testing; examination of the work area to ascertain that any work being built upon is complete and in conformance with Contract requirements; a physical examination of materials and equipment to assure that they conform to approved shop drawings or submittal data; and confirmation that all required materials and/or equipment are on hand.
 3. Initial inspections shall be performed as soon as a representative portion of the particular item of work has been accomplished. The Engineer, CQC Staff, Contractor's Superintendent and subcontractor performing the work, shall examine the representative portion of work to verify compliance with all Contract requirements, establish acceptable levels of quality and workmanship, review quality control testing and inspections for compliance with the Contract requirements and this Special Provision, confirm that defective, damaged or unapproved materials were not incorporated in the work.
 4. Follow-up inspections shall be performed by the CQC Staff, on a daily basis, to assure continuing compliance with the Contract requirements and established levels of quality and workmanship. Follow-up inspections shall confirm, on a daily basis, that defective, damaged or unapproved materials are not incorporated in the work.
 4. The Engineer shall be notified at least forty-eight (48) hours in advance of each preparatory and initial phase inspection.
 5. The CQC Plan Manager shall insure that all phases of inspection are made a matter of record in the CQC Plan documentation.
- G. Approval of the Contractor's CQC Plan shall not relieve the Contractor of its responsibility to comply with the requirements of the Contract Documents. The CQC Plan shall be revised or updated as directed by the Engineer. No additional cost or time extensions will be allowed for the Contractor's re-submission of

rejected Interim and Detailed CQC Plans or for revisions or updating of the Detailed CQC Plan during the course of the Contract, as directed by the Engineer.

- H. The Contractor shall provide and maintain gauges and other measuring and testing devices necessary to assure that articles conform to the Contract requirements. These devices shall be calibrated in accordance with national standards and certifications. Calibration certificates shall be maintained current and submitted to the Engineer. Any equipment exceeding its required re-calibration date or that becomes damaged or otherwise unreliable, shall be isolated, tagged, or otherwise marked to prevent its use without written permission of the Engineer.
- I. The CQC Plan Manager shall take prompt action to correct conditions that have resulted or might result in nonconforming materials, parts, components, installations, or functions/operations. This action shall include preventive measures as well as correction of conditions that have occurred. The CQC Plan Manager shall document the nonconforming work and his/her efforts to correct the deficiencies and to minimize their future occurrence. Nonconformance Reports shall document corrective actions performed and be submitted to the Engineer for approval.
- J. If the Contractor's work does not conform to the requirements of the Contract documents, the Engineer may issue a "Corrective Action" or "Nonconformance Report" to the Contractor. The Contractor must correct all deficiencies, or otherwise respond to the report, within seven (7) calendar days of issuance of the report by the Engineer. The Contractor shall not build upon or conceal any feature of the work containing uncorrected defects. If the work remains unresolved at the time of processing of the progress payment, the Engineer may withhold monies due to the Contractor until the deficiencies are corrected.
- K. If the Engineer determines that the Contractor's CQC Plan and/or its administration are deficient in the identification and correction of nonconforming work, the Engineer shall issue a "CQC Plan Deficiency Notice" identifying the specific deficiencies and required corrective actions. The Engineer's corrective actions may include modification of the CQC Plan, replacement of existing CQC Plan Staff or supplementing of CQC Plan Staff, all at no additional time or cost to the MAA. The Contractor shall correct all deficiencies in the CQC Plan as directed in writing by the Engineer. In the event that the Contractor fails to comply with the Engineer's directions, the Engineer may withhold monies due to the Contractor until the deficiencies are corrected.
- L. The CQC Plan Manager shall maintain current records for all inspections and tests performed throughout the life of the Contract, in a form approved by the Engineer. These records shall include, but not be limited to, factual evidence that the required inspections or tests have been performed, including type and number of inspections or tests involved, identification of inspectors and technicians, dates and results of inspections and tests, and deficient work identified including

proposed remedial and corrective actions to be taken. These records must include statements that all supplies and materials permanently incorporated in the work are in full compliance with the Contract documents. Legible copies of these records must be furnished to the Engineer daily, or at such other intervals as directed. The records shall cover all work performed subsequent to the previously furnished records and shall be verified by the CQC Plan Manager

- M. The CQC Plan Manager shall also prepare a monthly report, or at such intervals as directed by the Engineer, which summarizes all quality control operations. This summary report shall identify work performed, inspections made, tests performed, deficiencies found and corrective action taken during the month covered by the report.
- N. All original quality control records shall be maintained in a central, on-site, location by the Contractor and turned over to the Engineer at the completion of the Contract.
- O. The requirements to maintain quality control records, as described above, shall not be construed to relieve the Contractor from submitting samples, test data, shop drawings, material certificates, or other information required elsewhere in the Contract.

SP-8.06 Shop Drawings, Product Data, and Samples

A. General:

- 1. Shop drawings shall include, but are not limited to, drawings, diagrams and illustrations, material schedules, performance charts and data, product data and literature, technical specifications and test reports, engineering calculations, studies and reports and other data prepared by the Contractor, subcontractor, manufacturer, supplier, or distributor which illustrates how specific portions of the work shall be fabricated and/or installed. The Contract performance period outlined in the Contract Documents includes time for the review and approval of the Contractor's shop drawings. The Engineer's review of shop drawings, product/material samples, requested approved equals and substitutions shall be as follows:
 - a. Specified product/material samples (as defined below): twenty-one (21) calendar days minimum.
 - b. Shop drawings (as defined above): twenty-one (21) calendar days minimum.
 - c. Requests for approval of "Or Equal", or "Approved Equal" articles pursuant to Special Provision: **SP-5.03** or "Substitutions" pursuant to Special Provision: **SP-5.04**: forty-five (45) calendar days minimum.

- d. Review time will begin and end with dates received by and returned from the Construction Manager.
- e. The above minimum review times are to be used by the Contractor in developing the Detailed Schedule #1 required by Special Provision: **SP-8.03**.

B. Schedule of Shop Drawings and Submittal Register:

1. The Contractor shall be required to develop and maintain throughout the life of the project a Schedule of Shop Drawings and Submittal Register (hereinafter referred to as "Register"). The Register shall be submitted to the Engineer for approval with the Detailed Schedule #1 submission required by Special Provision: **SP-8.03** and shall conform to the following requirements:
 - a. The Register shall be a comprehensive listing of each and every shop drawing (as defined by paragraph A above), product/material samples and other submissions required by the Contract documents.
 - b. Each item listed on the Register shall have a unique submittal number. The submittal number shall incorporate the relevant: Technical Specification, section and paragraph numbers, or relevant Contract: General or Special Provision, section and paragraph number, and applicable revision or version numbers.
 - c. The Register shall be developed and maintained in a spreadsheet format similar to the attached "Register Example Form".
2. The Register shall indicate the Contractor's required submittal date for each item listed. The Contractor's required submittal date shall be determined as follows:
 - a. For submissions required by the General or Special Provisions, the Contractor's required submittal date shall be calculated by adding the number of calendar days specified to the date of issuance of the "Notice of Recommended Award" or "Notice to Proceed" (whichever is applicable).
 - b. For shop drawings and product/material sample submissions, the Contractor's required submittal date shall be calculated by taking the early installation date from the approved project CPM Schedule, subtracting the estimated procurement, fabrication and shipping duration, and subtracting the twenty-one (21) calendar day or forty-five (45) calendar day review time (whichever is applicable).

- c. For those shop drawings that can reasonably be expected to have multiple submittals prior to approval, the required submittal date should also reflect the additional time necessary for a second cycle of submission and review.
3. The Register shall become a scheduling document and shall be used to control submittals throughout the life of the Contract. The Register and the Project CPM Schedule shall be coordinated by inserting the Register into the Project Schedule to form one complete scheduling document.
4. The Contractor shall carefully control his/her procurement operations to ensure that each individual submittal is made on or before the Contractor's required submittal date shown on the Register. Failure by the Contractor to provide individual submittals on or before the Contractor's required submittal date shown on the Register may result in extended review times, beyond the minimum review times detailed above. The Contractor shall be held responsible for any delays associated with extended review times in the event that the submittals are late.
5. The Contractor shall update the Register each month to show actual submission dates, days late (if any), review status and review action. The Contractor shall provide two (2) printed copies and one (1) diskette with electronic file format of the updated Register, which shall be submitted to the Engineer with the monthly Progress Schedule Update required by Special Provision **SP-8.03**.

C. Submissions:

1. Samples, drawings, specifications, catalogs, etc., submitted for approval shall be properly labeled indicating specific service for which materials or equipment are to be used including, section and article numbers of the Specifications governing, Contractor's name, and title of the Contract. Catalogs, pamphlets or other documents submitted to describe items on which approval is being requested shall be specific and identification in catalogs, pamphlets, etc., of the item submitted shall be clearly made in ink. Data of a general nature will not be accepted. Six (6) samples are required on finish color submissions.
2. Any costs incurred by the Contractor or the Administration due to the resubmittal of documents caused by inaccuracy, lack of coordination, and/or checking shall be the responsibility of the Contractor. Each variation from the Contract Specifications and Drawings shall be noted on the submittal. The Contractor shall also state the reason for such variations. If these requirements are not met, the submittal may be returned for corrective action.

3. Fire related shop drawings shall be submitted via the Engineer for review and approval by the Office of the Fire Marshal. Submit six (6) 22"x34" paper hard copies and one (1) CD containing a PDF of the same.

D. Submittal Classification:

1. Administration Approved: Administration approval is required for extensions of design, critical materials, deviations, equipment whose compatibility with the entire system must be checked, and other items as designated by the Engineer. Within the terms of this Contract, they are considered to be "shop drawings".
2. Information Only: All submittals not requiring Administration approval will be for information only. They are not considered to be shop drawings as defined in Section A above.

E. Schedule of Submission:

The Contractor shall submit for approval two (2) sepia reproducible and two (2) ozalid prints of shop drawings as called for in the Specifications or necessary for the work. If any contradiction exists between this requirement and the particular Specification, this requirement shall supersede. Send Shop Drawings to the organization designated by the Administration at the pre-construction meeting.

F. Certificates of Compliance:

Any certificates required for demonstrating proof of compliance of materials with specification requirements shall be executed in six (6) copies. Each certificate shall be signed by an official authorized to certify in behalf of the manufacturing company. The certificate shall contain the name and address of the Contractor, the project name and location, the quantity and date or dates of shipment or delivery to which the certificate applies. Copies of laboratory test reports submitted with certificates shall contain the name and address of the testing laboratory and the date or dates of the tests to which the report applies. Certification shall not be construed as relieving the Contractor from furnishing satisfactory material that meet the requirements of the specification.

G. Templates/Patterns:

The Contractor shall furnish all necessary templates, patterns, etc., for installing work, and for the purpose of making the general arrangement of the systems. All work included in the Drawings and details shall be consulted in connection with mechanical and electrical installations. Where the exact location of fixtures and equipment are not specifically located, the Contractor shall obtain this information in the field or from the Engineer.

H. Process of Approval:

The Engineer, on receiving sepia reproducible, will promptly approve them or indicate desired corrections, and return one (1) sepia of each drawing to the Contractor. The Contractor shall make all corrections and resubmit drawings, which are not approved in accordance with requirements for first submission. If the Contractor considers any correction indicated on the submittals to constitute a change to the Contract, notice as required under General Provision: **GP-4.06-Changes**, shall be given promptly to the Engineer.

I. Withholding of Payment:

Payment for materials incorporated in the work will not be made if required approval has not been obtained.

J. Interpretation:

Approval by the Engineer shall not be construed as a complete check but will indicate only that the general method of construction and detailing is satisfactory. Approval of drawings shall not be considered as a guarantee of measurements of building conditions. Where drawings are approved, said approval does not mean the drawings have been checked in detail; said approval does not in any way relieve the Contractor from his/her responsibility or necessity for furnishing material or performing work as required by the Contract Drawings and Specifications.

K. Use:

Use of shop drawings in fabrication or erection will not be permitted until approved, stamped, and dated by the Engineer. All shop drawings will be numbered consecutively by the Engineer when approved. Before submission for approval, drawings and schedules shall be fully checked by the Contractor for materials, sizes, dimensions, details, and shall bear evidence of the Contractor's verification and approval. All drawings shall be on same size sheets.

L. Distribution:

After approval of the shop drawings, the Contractor shall furnish prints to other Contractors furnishing work which will or may be affected by his/her work.

M. Work Prosecution:

The Contractor shall follow drawings in laying out work and check drawings of the various trades to verify spaces in which work will be installed. Maximum headroom and space conditions should be maintained, and where they appear inadequate, the Engineer shall be notified before proceeding with installations.

N. Construction Drawings:

If directed by the Engineer, the Contractor shall, without extra charge, make reasonable modifications in layout as needed to prevent conflict with work of other trades or for proper execution of the work. Detailed drawings of proposed departures due to actual field conditions or other causes shall be submitted to the Engineer for approval and any such changes shall be made without additional cost to the Owner.

O. Additional Materials and/or Equipment:

Because of the small scale of the drawings, it is not possible to indicate all offsets, fittings, and accessories, which may be required. The Contractor shall carefully investigate the structural and finish conditions affecting his/her work and shall arrange such work accordingly, furnishing such fittings, valves, transitions, pull or junction boxes, and accessories as may be required to meet such conditions at no additional cost to the Owner.

P. Variances:

Where variances occur between the Contract Drawings and Specifications or within either document itself, the item or arrangement of better quality, greater quality, or higher cost shall be included in the Contract Price. The Engineer will decide on the item and manner in which the work shall be installed.

Q. Time Extensions:

Failure by the Contractor to submit revised Shop Drawings in ample time for further review shall not entitle him to an extension of Contract time, and no claim for extension by reason of such default will be allowed.

R. Quality Control:

1. Source limitations. To the greatest extent possible for each unit of work, and subject to the restrictions of the Buy American Act, provide products, materials, or equipment of a singular generic kind from a single source.
2. Compatibility of Options. Where more than one choice is available as options for the Contractor's selection of a product or material, select an option that is compatible with other products and materials already selected. Total compatibility among options is not assured by limitations within the Contract Documents, but must be provided by the Contractor. Compatibility is a basic general requirement of product/material selections.

S. Product Delivery/Storage/Handling:

Deliver, handle, and store products in accordance with manufacturer's recommendations and by methods and means that will prevent damage, deterioration, and loss, including theft, and protect against damage from climatic conditions. Control delivery schedules to minimize long-term storage of products at the site and overcrowding of construction spaces and staging area. In particular, provide delivery/installation coordination to ensure minimum holding or storage times for products recognized to be flammable, hazardous, easily damaged, or sensitive to deterioration, theft, and other sources of loss. Damaged or defective items, in the opinion of the Engineer, shall be replaced at no cost to the Administration.

T. Products:

1. General Product Compliance:

a. General. The compliance requirements for individual products, as indicated in the Contract Documents, are multiple in nature and may include generic, descriptive, performance, prescriptive, compliance with standards, conformance with graphic details, and other similar forms and methods of indicating requirements, all of which must be complied with.

b. Procedures for Selecting Products. The Contractor's options for selecting products are limited by Contract Document requirements and governing regulations, and are not controlled by industry traditions or procedures experienced by the Contractor on previous construction projects. Required procedures include, but are not necessarily limited to, the following for various indicated methods of specifying:

(1) Standards, Codes and Regulations. Where only compliance with an imposed standard, code, or regulation is required, selection from among complying products is the Contractor's option.

(2) Performance Requirements. Provide products that comply with specific performances indicated, and that are recommended by the Manufacturer (in published product literature) for the applications indicated. Overall performance of a product is implied where the product is specified with only certain specific performance requirements.

(3) Products Specified as Acceptable: Any products complying with the Specifications can be proposed whether listed specifically or not on the listing of acceptable products or manufacturers. Acceptable product items are listed for the

convenience of the Contractor, but are not to be considered an all-inclusive list.

- (4) Visual Matching. Where matching with an established sample is required, the Engineer will render the final judgement of whether a product proposed by the Contractor matches a sample satisfactorily.
 - (5) Visual Selection. Except as otherwise indicated, where specified product requirements include "... as selected from the Manufacturer's standard colors, patterns, textures..." or words of similar effect, the selection of manufacturer and basic product (complying with requirements) is the Contractor's option, and subsequent selection of color, pattern, and texture is the Engineer's selection. A phrase such as "...as selected from the Manufacturer's full color line..." means selection of standard or optional colors regularly produced by the selected manufacturer.
- c. General Requirements for Electrical Work: The following applies to electrical work unless otherwise specified:
- (1) Comply with the National Electrical Code.
 - (2) Conduits, Wiring and Equipment. Arrange generally as indicated. Any change resulting in a savings of labor or materials shall be made only in accordance with a contract change order. Deviations are permitted only where necessary to avoid interferences and only after drawings showing the proposed deviations have been submitted to and approved by the Engineer.
 - (3) Ratings. The motor horsepower and apparatus wattage ratings shown or specified are estimated values, and the corresponding sizes of feeders and other electrical equipment indicated to serve them are minimum sizes. Motors of greater horsepower and apparatus with larger wattage ratings may be furnished if necessary to meet the requirements of the various sections of the Specifications in which they are specified. Where larger motors or apparatus with larger wattage ratings are furnished, increase the capacity of the feeders and other electrical equipment serving them to correspond, at no additional cost to the Administration, in each case in which the Engineer determines that apparatus meeting the Specification requirements and requiring a horsepower or wattage not exceeding that listed is available from two or more sources.

2. General Product Requirements:

- a. **General.** All equipment, material, and articles incorporated into the work covered by this Contract shall be new and of the most suitable grade for the purpose intended, unless otherwise specifically provided in the Contract. References in the specifications to equipment, material, articles, or patented processes by trade name, make, or catalog number, shall be regarded as establishing a standard of quality and shall not be construed as limiting competition. The Contractor may, at its option, use any equipment, material, article, or process that, in the judgement of the Engineer, is equal to that named in the Specifications, unless otherwise specifically provided in the Contract. Provide products that are undamaged and unused at the time of installation, and that are complete with accessories, trim, finish, safety guards, and other devices and details needed for a complete installation and is suitable for the intended use and effect.
- b. **Standard Products.** Products shall be essentially the standard catalogued products of manufacturers regularly engaged in production of such products and shall be the manufacturers' latest standard design that complies with the Specification requirements. Equipment shall essentially duplicate items that have been in satisfactory commercial and industrial use at least two (2) years, or more if otherwise specified, prior to bid opening; or, in lieu thereof, shall have been used and operated in a test installation that, in the opinion of the Engineer, duplicates its field performance for the same period of time. The Engineer reserves the right to require the Contractor to submit evidence of this effect for approval. When two units of that same class of equipment are required, these units shall be the product of a single manufacturer; however, the component parts of the system may not require to be the products of the same manufacturer.
- c. **Continued Availability.** Products that, by nature of their application, are likely to be needed at a later date for maintenance and repair or replacement work shall be current models for which replacement parts are available.

U. Working Drawings for Falsework Systems:

1. Falsework systems plans (design and construction) shall be the responsibility of the Contractor. A copy of the plans and calculations shall be submitted to the Engineer for information only.

2. The Contractor shall utilize a Professional Engineer (PE) registered in the State of Maryland who has a minimum of five years experience in falsework design. The falsework design calculation and plans shall be signed by the PE and bear the seal of the PE. The submittal of the design and falsework plans shall include the PE's resume showing evidence of the required experience.
3. The Contractor's plans and design calculations shall evaluate and qualify all products and components including manufactured products and proprietary items for their intended service.
4. Every structure in the Contract will require a separate falsework design analysis, separate plans and design submittals as set forth above. This applies even though structures may appear to be identical.
5. Each falsework system shall be designed to have the capacity to support all vertical and horizontal loading with enough redundancy to prevent progressive failure. Vertical loading, differential settlement forces, live load where applicable and all horizontal lateral and longitudinal forces shall be taken into account. Unbalanced temporary loading caused by placement sequence shall also be provided for in the design. Adequate diagonal bracing in all planes shall be employed.
6. All falsework systems designs and plans shall provide for adequate foundations with bearings below the frost line or on rock or on piling and for possible settlement. If additional subsurface data is necessary, it shall be obtained and analyzed for proper design of the plans and performance of construction.
7. Falsework designs and plans shall include protection against impact from uncontrolled highway vehicles, accidental collision of a crane boom, or other construction equipment and vehicles, traffic vibration, flood waters, high winds, and any other envisioned contingent situations.

SP-8.07 Notice to the MAA of Labor Disputes

- A. If the Contractor has knowledge that any actual or potential labor dispute is delaying or threatens to delay the timely performance of this Contract, the Contractor shall immediately give written notice, including all relevant information, to the Engineer.
- B. The Contractor agrees to insert the substance of this clause in all subcontracts which are entered into under this Contract. All subcontractors shall be required to immediately notify the next higher tier subcontractor or the Prime Contractor of any actual or potential labor disputes that may affect, delay, or threaten the timely completion of this Contract.

SP-8.08 Record Drawings/As-Built Drawings

- A. The Contractor shall set aside at the site one (1) set of Contract Drawings to be used as the Project Record Drawings. The Contractor shall record on the Project Record Drawings all changes to show "As-Built" conditions. The Contractor shall also be responsible to assure that all changes made by his/her subcontractors be accurately shown as to the actual installation of all their work. Items to be included, but not limited to, are changes in sizes, grades, locations, and dimensions for all underground pipes, conduits, cables, valves, junctions, connections, and ends. All valves shall be numbered to correspond to valve tags and incorporated on printed lists.
- B. In addition to the above mentioned Record Drawings, the Contractor shall also provide and maintain on the job, in good order, a complete set of "As-Built" Drawings showing all changes made to the Contract Drawings during the entire construction period under this Contract. Upon completion of the work, this set of drawings, complete and up to date, shall be turned over to the Engineer.
- C. The as-built drawings will be jointly inspected for accuracy and completeness by the Engineers representative and the Contractor's representative prior to submission of each monthly pay estimate.
- D. The as-builts documents, including all attachments, shall be submitted to the Engineer electronically in a sign PDF file along with a hard copy. The Contractor shall prepare the as-built prints and pdf files for delivery to the Engineer at the time of Final Inspection for review and approval. These as-built marked pdf files and hard copy prints shall be neat, legible and accurate. If, upon review, the drawings are found to contain errors and/or omissions, they shall be returned to the Contractor for corrections. The Contractor will be liable for costs incurred by the MAA in regards to resources expended in the preparation of the necessary corrections. The Contractor shall complete the corrections and return the as-built marked prints to the Engineer within ten (10) calendar days.
- E. The Contractor's work may be suspended or payments may be withheld if the Contractor fails to maintain updated Project Record Drawings, or to submit the required "as-built" drawings as indicated above, subject to the satisfaction and approval of the Engineer.

SP-8.09 Project Completion and Punchlists

- A. Prior to or at the Final Inspection for acceptance of the Contract or portion/phase of the Contract, a punchlist will be developed by the MAA to identify items of work remaining to be completed, unacceptable, or defective. The Contractor shall have time allotted to complete the punchlist that shall be equal to ten (10) percent of the original Contract time plus ten (10) percent of any time added by change orders. When the project is to be performed in phases as required by the Contract

Specifications, the Contractor shall be allotted ten (10) percent of the specified time for each phase. The time shall begin on the date of notice, when served prior to final acceptance, or on the day of final acceptance for the entire Contract or any portion or phase of the Contract as applicable. Any portion of a day shall be counted as a full day.

- B. The Contractor is hereby advised that once the facility has been “Accepted for Maintenance” by the MAA, access to the facility for performance of punchlist work must be coordinated with the MAA and Airport Tenants and shall be subordinate to MAA and Airport Tenant operational and security requirements.
- C. Failure by the Contractor to complete any punchlist items in the allotted time may result in the MAA causing the incomplete punchlist items to be completed by others, without further notice to the Contractor.
- D. In the event that the MAA has incomplete punchlist items completed by others pursuant to Paragraph C above, the Contractor shall be assessed all direct costs incurred by the MAA plus an administrative fee equal to thirty percent (30%) of the direct costs. The MAA shall deduct said direct costs and administrative fee from any monies due or to become due the Contractor under this Contract.
- E. In the event that the MAA allows the Contractor to continue work on punchlist items beyond the allotted time, the MAA shall deduct from any monies owed Contractor, all construction management and inspection costs it incurs as a result of the work being performed beyond the allotted time.
- F. Warranties shall be in effect from the date of final acceptance for maintenance pursuant to **GP-5.13**, Acceptance for Maintenance.
- G. Notwithstanding General Provision: **GP-8.09**-Liquidated Damages, and as may be specified elsewhere in the Contract, the Contractor shall pay, indemnify, and save harmless the MAA from all suits, actions, claims, demands, damages, losses, expenses, and/or costs of every kind and description to which the MAA may be subjected to resulting from non-completion of the Contract which negatively affects separate Contractors on adjoining or overlapping work. The whole or so much monies due or become due the Contractor under the Contract, as may be considered necessary by the MAA, may be retained by the Administration until such suits or claims for damages shall have been settled, or otherwise disposed of, and satisfactory evidence to that effect furnished to the Procurement Officer. This obligation is not limited by, but is in addition to, the Performance Bonds contained in the Contract.

SP-8.10 Time Extensions for Unusually Severe Weather

- A. This provision specifies the procedure for determination of time extensions for unusually severe weather, for weather dependent contracts, in accordance with

GP-8.08, Termination for Default - Damages for Delay - Time Extensions, Paragraph D.1. In order for the Engineer to award a time extension under this clause, the Engineer must be satisfied that the following conditions exist.

1. The weather experienced at the project site during the Contract period must be found to be unusually severe, that is, more severe than the adverse weather anticipated for the project location during any given month;
 2. The unusually severe weather must actually cause a delay to the completion of the Contract. The delay must be beyond the control and without the fault or negligence of the Contractor.
 3. Time extensions for unusually severe weather occurring beyond the contractual completion date will not be granted if the contract duration has extended beyond the contractual completion date due to Contractor delay.
- B. The following schedule of monthly anticipated adverse weather delays is based on National Oceanic and Atmospheric Administration (NOAA) or similar data for the project location and will constitute a baseline for monthly weather time evaluations. The Contractor's progress schedule must reflect these anticipated adverse weather delays in all weather dependent activities.

Monthly Anticipated Adverse Weather Delays

<u>Jan</u>	<u>Feb</u>	<u>Mar</u>	<u>Apr</u>	<u>May</u>	<u>Jun</u>	<u>Jul</u>	<u>Aug</u>	<u>Sep</u>	<u>Oct</u>	<u>Nov</u>	<u>Dec</u>
8	7	7	8	8	7	5	6	4	6	5	5

- C. Upon issuance of the NTP and continuing throughout the Contract, the Contractor will record on the daily CQC Report, the occurrence of adverse weather and resultant impact to normally scheduled work. Actual adverse weather delay days must prevent work on critical activities for fifty percent (50%) or more of the Contractor's scheduled work day. The number of actual adverse weather delay days shall include days impacted by actual adverse weather to be calculated chronologically from the first to the last day of each month, and be recorded as full days. If the number of actual adverse weather delay days exceeds the number of days anticipated above, the Engineer will convert any qualifying delays to calendar days and issue a time extension in accordance with the General Provisions Section **GP-8.08**, Termination for Default - Damages for Delay - Time Extensions and **SP-8.03** Critical Path Method Schedule. Time extensions for unusually severe weather shall not be compensable.

SP-8.11 Operating and Maintenance Data

The Contractor shall submit to the Engineer, when the project is forty percent (40%) complete, a list of proposed maintenance and instruction manuals to be furnished to the

Administration, and the scheduled dates of all required field instruction to be provided by the Contractor-furnished personnel or the Manufacturer's representatives. All maintenance and instruction manuals must be furnished to the Engineer at least two weeks prior to the scheduled dates of any required Contractor-furnished field instructions or at least one month prior to project completion, if no Contractor-furnished field instructions are required.

SP-8.12 Order of Precedence of Specifications/Standard Provisions/Plans

“The order of precedence of contract documents shall be as follows:

1. Bid Forms
2. General Provisions
3. Special Provisions
4. Technical Specifications
5. Drawings

In the event of a conflict between contract documents, the earlier listed above shall prevail.”

SECTION 9 PAYMENT

SP-9.01 Hours of Labor, Wages, and Payroll Reporting

- A. The Contractor and all subcontractors shall comply with the provisions of applicable State of Maryland Law relative to minimum wage rates, hours of labor, overtime wages, apprenticeship, and payroll reporting.
- B. The Contractor's attention is also directed to the provision of the **Fair Labor Standards Amendments of 1974 P.L. (93-259)**. The minimum wage paid to all workmen employed on this Contract shall be in accordance with **Article 100** of the Annotated Code of Maryland.
- C. It is mandatory upon the successful bidder, and any subcontractors, on contracts over Five Hundred Thousand Dollars (\$500,000):
 - 1. To pay not less than the wage rates specified in Wage Rates Section of the Technical Provisions to all workmen employed in the execution of the Contract (Reference Annotated Code of Maryland **Article 100, Section 96.107** inclusive); and
 - 2. The Contractor shall submit two (2) complete copies of his payroll records and the payroll records of each of his subcontractors - one (1) copy to the Procurement Officer and one (1) copy to the Commissioner of Labor and Industry, Prevailing Wage Unit, 1100 N. Eutaw Street, Room 607, Baltimore, Maryland 21201, where they will be available for inspection during business hours.
- D. The payroll records must be submitted within fourteen (14) calendar days after the end of each payroll period and shall contain the following information:
 - 1. Name, address, and telephone number of the Contractor or the Subcontractor;
 - 2. Contract title, number, and location;
 - 3. Employees' names, addresses, social security numbers, exact and specific work classification, hours - straight time and overtime worked each day, total hours - straight time and overtime worked, rate of pay and gross wages earned. Employees' addresses may be dropped after it has been reported one time.
- E. Payrolls shall be submitted on US Department of Labor Wage and Hour Public Contracts Division Payroll Form WH-347 or its equivalent and contain only

information relevant to the job and be serially-numbered starting with payroll number one.

- F. The Contractor shall be responsible for submission of all subcontractor payroll records covering work performed directly at the work site. Each copy of the payroll records shall be accompanied by a statement, signed by the Contractor or the subcontractor, indicating:
1. that the wage rates contained therein are not less than those established by the Commissioner as set forth in the Contract;
 2. that the classification set forth for each workman or apprentice conforms with the work he/she performed; and
 3. that the Contractor or subcontractor, as the case may be, has complied with the provisions of the law.
- G. If the Contractor is delinquent in submitting payroll records, processing of partial payment estimates may be held in abeyance pending receipt of the records. In addition, if the Contractor is delinquent in submitting his payroll records, the Contractor shall be liable for liquidated damages.
- H. Only registered apprentices will be shown as such on payroll. Include for each apprentice proof that the apprentice is in an apprenticeship program registered with the Maryland Apprenticeship and Training Council of the Maryland Department of Labor, Licensing, and Regulation; and approved by the Bureau of Apprenticeship and Training, U.S. Department of Labor. Include written evidence of registration, including step and percentage of the journeyman's rate with the first payroll on which the apprentice appears.
- I. Apprentices shall be paid a percentage of the determined prevailing journeyman wage rate for the specific trade according to the apprentice progressive wage scale on file with the Maryland Apprenticeship and Training Council or other State Apprenticeship Agency recognized by the Bureau of Apprenticeship and Training, US Department of Labor.
- J. Overtime rates (not less than time and one-half the prevailing hourly rate of wages) shall be paid by general contractors and subcontractors under their contracts and agreements with their employees which in no event shall be for all hours worked in excess of ten (10) hours in any one calendar day or work performed on Sundays and legal holidays.
- K. Contractors and subcontractors before employing a classification or subclassification of workers or any trade or craft for which a wage rate was not issued, will submit a letter to the Commissioner of Labor and Industry stating the proposed rate of pay and

listing at least three (3) of their recent jobs in the same locality on which the proposed rate of pay, or less, was paid to such workers.

SP-9.02 Contractor's Invoice

- A. All construction contracts which have a Minority Business Enterprise (MBE) goal, the Contractor must complete a monthly MBE Utilization Statement and include this statement with its monthly invoice. Failure to complete and submit this form, may delay payment to the Contractor.
- B. The form is included in these Special Provisions, Section 10, Forms, **SP-10.05**, Minority Business Enterprise Utilization Statement, as well as, the Technical Provisions.

SP-9.03 Payment for Stored Materials

When the Contractor requests payment allowance for materials in accordance with **GP-9.01**, Payment, Paragraph C, the following terms and conditions will apply:

- A. For permanent materials delivered to the project site, or stored in an approved location off-site, an allowance of one hundred percent (100%) of the material cost plus freight charges as invoiced may be made. The allowance will be based upon validated invoices or bills for such materials, including freight charges, and a copy thereof shall be made a part of the documented records for the project. All permanent materials approved for payment will have been tested by the Administration for compliance with the requirements of the Contract Documents. Payment will only be made for permanent materials which conform to the requirements of the Contract Documents.
- B. No allowance will be made for fuels, form lumber, falsework, temporary structures or other materials of any kind which will not become an integral part of the finished construction.
- C. All permanent materials for which an allowance is requested shall be stored in an approved manner where damage is not likely to occur. If any of the stored materials are lost or become damaged in any manner, the Contractor shall be responsible for repairing or replacement of such damaged materials. The value of the lost or damaged permanent material will be deducted from the Contractor's subsequent progress payments until replacement has been accomplished.
- D. Permanent material for which payment has been made, either wholly or partially, shall not be removed from the approved location until such time that it is incorporated into the work, unless authorized by the Engineer.
- E. The following must accompany the written request for payment of stored materials:

1. Consent of the Surety specifying the material type and the bid items in which the material is to be used.
2. Validated invoices showing that payment for the material has been made.
3. A notarized statement from the Contractor attesting that the invoices, as submitted do not include charges and/or fees for placing, handling, erecting or any other charges and/or markups other than the actual material cost, sales tax(es) if applicable, and freight charges.
4. Bill of lading showing delivery of the material.
5. Inspection test reports, certifications required by the Contract Documents and approved by the Engineer.
6. Nothing in these specifications shall be interpreted as requiring the Administration to pay for stored materials. The Administration shall decide on a case-by-case basis whether stored materials shall be paid for. Some factors the Administration will consider are: the Contractor's ability to meet the project schedule and milestones, the effectiveness of the Contractor's Quality Control Plan, the number of unilateral extra work orders the Administration issues, how record drawings are being kept up, the status of material submittals, the effectiveness of the Contractor's safety, erosion and sediment control programs and the on-going cleanliness of the project site. No payment will be made for stored materials which have not been submitted and accepted.
7. If the permanent material is stored outside of the general vicinity of the airport, the Contractor must pay for the Administration's representative's transportation and lodging to the see the permanent materials.

SP-9.04 Negotiated Payment

- A. Changes, omissions, and extra work shall be authorized and ordered, in writing, by the Engineer by one of the following methods:
 1. Issuing, in advance of its performance, a written order describing the change, adjusting the Contract Lump Sum or Bid Total Price, and extending or reducing the Contract time as the case may be.
 2. A written change order in which is described the change but which will not involve any adjustment in the Contract Lump Sum or Bid Total Price or the Contract time.

3. A written change order for work to be performed on a time and material basis or Contract fixed unit price basis. Upon completion of the work, a written order adjusting the Contract Lump Sum or Bid Total Price and extending the Contract time will be issued.
- B. For each change, omission, or extra work ordered by the Engineer, the Contractor shall submit a proposal in writing to the Engineer in a lump sum amount and shall state the extent to which the Contract time shall thereby be increased or decreased. The Engineer shall, by written demand, require the Contractor to submit a fully itemized breakdown of said Lump Sum Price in such form as he may designate to facilitate checking of said Lump Sum Price if the latter is in excess of ONE THOUSAND DOLLARS (\$1,000).
 - C. For negotiated cumulative change orders in excess of ONE HUNDRED THOUSAND DOLLARS (\$100,000), the Contractor must execute a Truth-In-Negotiation Certificate vouching for the accuracy of most factors. The Certificate will be issued to the Contractor by the Engineer when required. If the Engineer, by written order, changes or directs that extra work be performed and thereby eliminates the performance of some part of the Contract, and if either the lump sum cost of (1) the change or extra work, or (2) the part eliminated is in excess of ONE THOUSAND DOLLARS (\$1,000), the Engineer shall require an itemized breakdown of both. The Contractor shall furnish, as requested by the Engineer, invoices from suppliers or other data in substantiation of the Contractor's cost. All proposals and breakdowns shall be submitted promptly to the Engineer within twenty (20) days from the date the change order is initiated, whether it should originate from the Contractor's request, a design change, or a determination of the Engineer.
 - D. If a change involves merely an omission and no extra work, the Contract Price shall be reduced by the amount it would always cost the Contractor if the omitted item or work had not been eliminated, but the Contractor and the subcontractors shall each receive a sum not in excess of five percent (5%) overhead. If a change involves both an increase in cost and a decrease in cost of the Contract work, no overhead or profit shall be allowed on what the cost of the omitted work would have been. Items of expense as set forth in paragraph (G) will not be allowed as part of the cost of omissions or extra work as such items are deemed to be reimbursed by overhead allowances.
 - E. Percentage allowances for overhead and profit will be made to the Contractor and subcontractors, but under no circumstances will such percentages be allowed for work sublet by a subcontractor.
 - F. The allowable percentages shall be:
 1. For changes in excess of ONE THOUSAND DOLLARS (\$1,000) total cost before overhead and profit, but not exceeding TWENTY-FIVE THOUSAND DOLLARS (\$25,000) total cost before overhead and profit. The Contractor on

all work performed with his own organization will be allowed fifteen percent (15%) overhead and five percent (5%) profit. Subcontractors on all work performed with their own organization will be allowed ten percent (10%) overhead and five percent (5%) profit. On work performed solely by a subcontractor, the Contractor will be allowed five percent (5%) of the total cost of labor, materials and Performance Bond as his overhead and profit.

2. For changes exceeding TWENTY-FIVE THOUSAND DOLLARS (\$25,000) in total cost before overhead and profit. Allowable percentages for overhead and profit will be determined for each particular change after special consideration of the nature, extent, and complexity of the work involved, but in no instance shall such percentages exceed the percentages in paragraph (F1).
- G. The allowable percentages of cost for overhead and profit are deemed to include, but not to be limited to, the following:
1. Job supervision and field office expense required by the Contract; expenses for timekeepers, clerks, and watchmen; cost of correspondence of any kind and insurance not specifically mentioned herein; all expenses in connection with the maintenance and operation of the field office; use of small tools and cost of small trucks generally used for transporting either workmen, materials, tools or equipment to job locations; and incidental job burdens.
 2. No percentage allowances will be made for maintenance or operation of Contractor's regularly established principal office, branch office, or other similar facilities.
- H. Should the Contractor and the Engineer fail to agree upon a Lump Sum Price, the Engineer shall have the right to issue an order for the work to be changed or to be done as extra work on a time and material basis and a correct account shall be kept by the Contractor for the actual cost of all labor, materials, and equipment as described in **GP-9.02**.

SP-9.05 Force Account Work

In addition to **GP-9.02**, Force Account Work (Paragraph 3), the following requirements shall apply:

"The Rental Rate Blue Book" applies only to rented equipment. The "Cost Reference Guide" applies to contractor-owned equipment. Delete the words "rental" in Paragraphs A. through G., as appropriate.

- A. The Contractor shall receive the current rental rates recommended in the Rental Rate Blue Book for Construction Equipment for the use of any machinery or special equipment authorized by the Engineer. The rental rates must be agreed upon in

writing before work is begun, except in those cases where the Engineer finds that an emergency exists. Payment will be made for the actual number of hours the equipment is at the work site. The maximum number of hours allowed for each working day will be eight (8) or the actual number of hours in operation, whichever is greater. Weekly rates will be used on the force account project if the total time exceeds three (3) days. Monthly rates will be used for all equipment used on the force account project if the total time exceeds three (3) weeks.

- B. Approved transportation charges will be paid from and to the nearest source if the equipment is brought to the project specifically for use on the force account work and is not used on any other work.
- C. The rental rate will consist of the sum of the rate for the basic piece of equipment, the rates for attachments (where applicable), and the estimated hourly operating cost.
- D. The above component parts of the rate are to be obtained from the Rental Rate Blue Book when listed in that book. If a piece of equipment is not listed in the Rental Rate Blue Book, then the rate will be the prevailing rate being paid in the area where the force account work is being performed.
- E. When the equipment is used in excess of eight (8) hours per day, or forty (40) hours per week, the excess time will be considered as overtime. The rental rates for this overtime will be the sum of fifty percent (50%) of the rate for the basic piece of equipment, fifty percent (50%) of the rates for attachments where applicable and one hundred percent (100%) of the estimated hourly operating costs above.
- F. Whenever equipment is ordered by the Engineer to be held on the project on a standby basis, or when the Administration is obligated for other reasons to pay for idle equipment, the rate will be seventy five percent (75%) of the rental rate with no allowance for operating costs. Standby or idle time cannot exceed eight (8) hours per day and will not be allowed for Saturday, Sunday, or holidays. Non-operating time for equipment required for force account work is not considered standby or idle time if the equipment is operated and used at least once during each working day.
- G. Regional Rate Modifications and Life Expectancy Adjustments will not be allowed.

SP-9.06 Progress Payments

In addition to **GP-9.03**, Progress Payments, the following information and documentation is required to be included in any proper invoice for payment.

- A. Original construction schedule, look-ahead construction schedule, updated construction progress schedule, recovery construction schedule, whichever are appropriate.
- B. Certified payroll records for the General Contractor and all subcontractors working on the Contract.
- C. Certification that the as-built drawings have been updated and jointly reviewed by the Engineer and the Contractor's representative for the month that payment is requested.
- D. Copies of invoices and all documentation necessary for payment with regards to materials stored which have not been incorporated into the work, but for which payment is requested.
- E. Copies of completed Monthly Minority Subcontractor Utilization Forms.
- F. Certification of payment from the subcontractors as required by **GP-9.01**, Scope of Payment.
- G. Copy of all the Contractor's Quality Control Reports for the period being invoiced.
- H. Contractor Quality Control Plan submitted by the Contractor and approved by the Engineer.
- I. Contractor Safety Plan and/or reports submitted by the Contractor and approved by the Engineer.

The Contractor is responsible to submit with its invoice, additional information or documentation which may be required elsewhere in this Contract. If the Contractor does not submit the required information, processing of the progress payment may be withheld by the Engineer, or the Administration.

SP-9.07 Prompt Payment to Subcontractors

In accordance with the 1999 Laws of Maryland, Chapter 687, State Finance and Procurement Article, the Maryland State Law on prompt payment, effective October 1, 1999, is summarized below.

- A. It is the policy of the State that a contractor shall promptly pay a subcontractor any undisputed amount that a subcontractor is entitled to under a State procurement contract for construction. "Undisputed amount" includes the retainage on a contract.

1. This payment shall be made within ten (10) days of receiving a progress payment or final payment from the State.
2. If a contractor withholds payment, the contractor shall:
 - a. notify the subcontractor, in writing within the same ten (10) day time period, stating the reasons for payment being withheld,
 - b. provide a copy of the notice to the procurement officer.
3. If a subcontractor does not receive payment within the required time period, the subcontractor may give written notice of non-payment to the procurement officer. The notice shall include:
 - a. the name of the contractor, the project under which the dispute exists and the amount in dispute,
 - b. provide an itemized description on which the amount is based and
 - c. if known, provide an explanation for any payment dispute.
4. Within two (2) business days of receipt of written notice from a subcontractor, a modal representative shall verbally contact the contractor to determine if the amount withheld is undisputed.
5. If the modal representative determines that all or some of the amount is undisputed, the representative shall instruct the contractor to pay the subcontractor the undisputed amount within three (3) business days. The modal representative shall verbally inform the subcontractor the results of discussions with the contractor.
6. If the payment is not made, the subcontractor may report the non-payment to the procurement officer. As a result, the modal representative shall schedule a meeting of the modal project manager, the subcontractor and the contractor, as follows:
 - a. the time and location shall be selected by the modal representative,
 - b. the meeting shall be no later than ten (10) days after receiving notice from the subcontractor,
 - c. the meeting purpose is to establish the reasons for non-payment,
 - d. the modal representative shall require the parties to provide information necessary to evaluate the dispute,

- e. if the modal representative determines the contractor is delinquent, further progress payments to the contractor may be withheld until the subcontractor is paid.
7. If the payment to the subcontractor is not made within seven (7) days after the modal representative determines that the contractor is delinquent, the modal representative shall schedule a second meeting on the dispute as follows:
- a. the time and location shall be selected by the modal representative,
 - b. the meeting shall be no later than five (5) days after the close of the seven (7) day period.
8. After this second meeting, if the modal representative determines the contractor continues to be delinquent in subcontractor payments, he/she:
- a. shall order further payments to the contractor not be processed until payment is made to and verified with the subcontractor,
 - b. may order work under the contract be suspended based on the contractor's failure to meet contractual obligations under the contract,
 - c. may require the contractor to pay a penalty to the subcontractor, not to exceed \$100 per day, from the date that the payment was required, not to include any period that the modal representative determines that the subcontractor was not diligent in reporting non-payment to the procurement officer.
9. The contractor or subcontractor may appeal the decision after the second meeting, noted above to the procurement officer. The contractor shall comply with the procurement officer's decision.
10. An act, failure to act or decision of the procurement officer or modal representative may not:
- a. affect the rights of the contracting parties under other provision of law,
 - b. be used as evidence on the merits of a dispute between the modal administration and the contractor or the contractor and the subcontractor in any other proceeding or
 - c. result in liability against or prejudice the rights of the modal administration or the Maryland Department of Transportation.

11. A decision of a procurement officer or a modal representative designated by the procurement officer under this law is not subject to judicial review or the provision for bid protests and contract claims before the Board of Contract Appeals. This law shall be construed only prospectively and may not be applied or interpreted to have any effect on or application to any State procurement contract awarded before the effective date of this law, October 1, 1999.

Federally-Financed Contracts:

In accordance with 49 CFR Part 26, Section 26.29, retainage must be returned within ten (10) days "after the subcontractor's work is satisfactorily completed", as determined by the prime contractor and reviewable by the Contract Administrator for the specific contract. The determination shall be based upon the comparison of the specific contract specifications with the actual work completed.

SECTION 10 STANDARD PROVISIONS FORMS

SP-10.01	Request for Information (SP-4.14)	136
SP-10.02	Substitution Request (SP-5.04)	137
SP-10.03	Subcontractor Statement of Acknowledgement (SP-8.01)	139
SP-10.04	Submittal Register (SP-8.06)	140
SP-10.05	Minority Business Enterprise Utilization Statement (SP-9.02)	141
SP-10.06	Monthly Injury Report (SP-6.04)	144
SP-10.07	Base Bid Schedule of Values (SP-2.02)	145
SP-10.08	Energized Equipment Work Permit (SP-4.17)	146

SP-10.01 Request for Information (SP-4.14)

Contractor:		Contractor's Architect:	
Address:		Address:	
Phone:		Phone:	
Contract Title:		Contract Number:	
RFI Number:	Date of Request:	Date Response Required (7 days minimum):	
Description of RFI:			
As Built Sketches Enclosed:	Specification Paragraph Ref:	Drawing Reference:	
Contractor's Recommendation:			
Cost Impact:		Schedule Impact:	
Subcontractors Affected:			
Subcontractors Coordinated With:			
Submitted by:			
Architect/Engineer's Response:			
Response by:		Date:	

SP-10.02 Substitution Request (SP-5.04)

Contract Title:	Item #:
Contract Number:	Section #:
Contractor:	Paragraph #:
Item Specified:	
Proposed Substitution:	

Fill in the blanks below (incomplete forms will not be considered):

- A. Does the substitution affect dimensions shown on the Drawings?
Yes _____ No _____

- B. Will the undersigned pay for changes to the building design, including engineering and detailing cost caused by the requested substitution?
Yes _____ No _____

- C. What affect does substitution have on other trades?

- D. What affect does substitution have on construction schedules?

- E. Manufacturer's guarantees of proposed and specified items are:
Same _____ Different _____

Explain if different:

- F. Reason for Request:

- G. Itemized comparison of specified item with the proposed substitution; list significant variations:

- H. Accurate cost data comparing proposed substitution with product specified:

- I. Designation of maintenance services and sources:

- J. Attach complete technical data, including laboratory tests, if applicable.
- K. Include complete information on changes to Drawings and/or Specifications which proposed substitution will require for its proper installation.
- L. Submit with the request all necessary samples and substantiating data to prove equal quality and performance to the item specified in the Contract. Clearly mark the Manufacturer's literature to indicate equality in performance.

The Contractor certifies that the proposed substituted product is of equal performance and assumes the liability for equal performance, design, and compatibility with adjacent materials.

The undersigned states that the function, appearance, and quality of the proposed substituted product is equivalent or superior to the specified item/product. Signature shall be the principal having the authority to legally bind his/her firm to the above terms. Failure to provide legally binding signature will result in retraction of approval.

Corporate Officer: _____

Signature _____ Date _____

Address: _____

SP-10.03 Subcontractor Statement of Acknowledgement (SP-8.01)

PART I - STATEMENT OF PRIME CONTRACTOR		
1. PRIME CONTRACT #:	2. CONTRACT TITLE:	
3. SUBCONTRACTOR #:	4. DATE SUBCONTRACT AWARDED:	
4. PRIME CONTRACTOR (Name, Address, Phone)	5. SUBCONTRACTOR (Name, Address, and Phone)	
6. The Prime Contractor states that under the Contract shown in Item 1, a subcontract was awarded on the date shown in Item 4 by (name of awarding firm): _____ to the subcontractor in Item 5 for the following work: _____ _____ _____		
7. _____ Name and Title	8. _____ Signature	9. _____ Date
PART II - ACKNOWLEDGEMENT OF SUBCONTRACTOR		
10. The subcontractor acknowledges that, as a minimum, the following clauses of the Contract shown in item 1 are included in the subcontract:		
GENERALSPECIALFEDERAL-AID CONTRACTOR AFFIRMATIVE PROVISIONSPROVISIONSPROVISIONSACTION PROGRAM GP-2.05SP-1.06FAA-1.04AAP-1.01 GP-7.01SP-6.03FAA-1.05AAP-2.02 GP-7.02SP-6.04FAA-1.06 GP-7.05SP-6.05FAA-1.07 GP-7.13SP-6.06FAA-2.06 GP-7.14SP-8.01FAA-2.12 GP-7.20SP-8.07FAA-4.02 GP-7.23SP-9.01FAA-4.03 GP-7.30FAA-4.05 GP-7.36 GP-8.01 GP-9.01		
11. NAMES(S) OF ANY HIGHER, OR LOWER TIER SUBCONTRACTORS, IF ANY:		
12. _____ Name and Title	13. _____ Signature	14. _____ Date

SP-10.04 Submittal Register (SP-8.06)

CONTRACT TITLE		CONTRACT NUMBER								
PROJECT LOCATION		CONTRACTOR								
ITEM NUMBER	DESCRIPTION OF ITEM SUBMITTED	TYPE OF SUBMITTAL	CLASSIFICATION	CONTRACTOR SCHEDULE DATES		CONTRACTOR ACTION		MAA ACTION		REMARKS
				SUBMIT	APPROVAL MATERIALS NEEDED BY	DATE	SUBMIT TO MAA	SUBMIT	DATE	
		MA	MA							
		APP	APP							
		PROV	PROV							
		AL	AL							
		SI	SI							
		IN	IN							
		FL	FL							
		Y	Y							
		SH	SH							
		OP	OP							
		DR	DR							
		W	W							
		A	A							
		B	B							
		S	S							
		T	T							
		ES	ES							
		T	T							
		IR	IR							
		R	R							
		E	E							
		P	P							
		R	R							
		E	E							
		S	S							
		B	B							
		A	A							
		S	S							
		H	H							
		A	A							
		M	M							
		P	P							
		S	S							
		L	L							
		D	D							
		E	E							
		S	S							
		A	A							
		M	M							
		P	P							
		S	S							
		L	L							
		D	D							
		E	E							
		S	S							
		A	A							
		M	M							
		P	P							
		S	S							
		L	L							
		D	D							
		E	E							
		S	S							
		A	A							
		M	M							
		P	P							
		S	S							
		L	L							
		D	D							
		E	E							
		S	S							
		A	A							
		M	M							
		P	P							
		S	S							
		L	L							
		D	D							
		E	E							
		S	S							
		A	A							
		M	M							
		P	P							
		S	S							
		L	L							
		D	D							
		E	E							
		S	S							
		A	A							
		M	M							
		P	P							
		S	S							
		L	L							
		D	D							
		E	E							
		S	S							
		A	A							
		M	M							
		P	P							
		S	S							
		L	L							
		D	D							
		E	E							
		S	S							
		A	A							
		M	M							
		P	P							
		S	S							
		L	L							
		D	D							
		E	E							
		S	S							
		A	A							
		M	M							
		P	P							
		S	S							
		L	L							
		D	D							
		E	E							
		S	S							
		A	A							
		M	M							
		P	P							
		S	S							
		L	L							
		D	D							
		E	E							
		S	S							
		A	A							
		M	M							
		P	P							
		S	S							
		L	L							
		D	D							
		E	E							
		S	S							
		A	A							
		M	M							
		P	P							
		S	S							
		L	L							
		D	D							
		E	E							
		S	S							
		A	A							
		M	M							
		P	P							
		S	S							
		L	L							
		D	D							
		E	E							
		S	S							
		A	A							
		M	M							
		P	P							
		S	S							
		L	L							
		D	D							
		E	E							
		S	S							
		A	A							
		M	M							
		P	P							
		S	S							
		L	L							
		D	D							
		E	E							
		S	S							
		A	A							
		M	M							
		P	P							
		S	S							
		L	L							
		D	D							
		E	E							
		S	S							
		A	A							
		M	M							
		P	P							
		S	S							
		L	L							
		D	D							
		E	E							
		S	S							
		A	A							
		M	M							
		P	P							
		S	S							
		L	L							
		D	D							
		E	E							
		S	S							
		A	A							
		M	M							
		P	P							
		S	S							
		L	L							
		D	D							
		E	E							

SP-10.05 Minority Business Enterprise Utilization Statement (SP-9.02)

Contract Title:	Page _____ of _____
Contract Number:	Date:
Contractor Name:	Invoice Number:
MBE Utilization To-Date (%):	MBE Goal (%):

GENERAL CONTRACTOR STATEMENT		
Payment Through Last Period	Payment This Period	Total Payment To-Date
MBE SUBCONTRACTOR PARTICIPATION		
Payment Through Last Period	Payment This Period	Total Payment To-Date
MBE Subcontractor Number 1 (Name):		
MBE Subcontractor Number 2 (Name):		
MBE Subcontractor Number 3 (Name):		
MBE Subcontractor Number 4 (Name):		
MBE Subcontractor Number 5 (Name):		
MBE Subcontractor Number 6 (Name):		
MBE Subcontractor Number 7 (Name):		

SP-10.06 Monthly Injury Report (SP-6.04)

MONTHLY INJURY/ILLNESS REPORT

(TO BE COMPLETED AND MAILED BY THE 7TH DAY OF EACH MONTH)

FOR THE MONTH OF: _____

PROJECT NUMBER: _____ PROJECT NAME: _____

PROJECT LOCATION: _____

CONTRACTOR OR SUBCONTRACTOR
NAME: _____

ADDRESS: _____

TELEPHONE NO.:

FAX NO.:

1. HOURS WORKED

2. LOST TIME CASES

3. RECORDABLE CASES

4. LOST WORK DAYS

5. CARRY OVER LOST WORK DAYS

6. TOTAL LOST WORK DAYS

COMMENTS:

PREPARED BY:

DATE:

SP-10.07 BASE BID SCHEDULE OF VALUES (SP-2.02)

**MARYLAND AVIATION ADMINISTRATION
CONTRACT NO. MAA-C0-00-000**

BASE BID SCHEDULE OF VALUES

Division	Item	General Contractor		Subcontractors		Total Costs
		Labor	Materials	Labor	Materials	
Division 02	Site Work					
Division 03	Concrete					
Division 04	Masonry					
Division 05	Metals					
Division 06	Carpentry					
Division 07	Moisture Protection					
Division 08	Doors, Windows, Glass					
Division 09	Finishes					
Division 10	Miscellaneous Specialties					
Division 11	Equipment					
Division 12	Furnishings					
Division 13	Special Construction					
Division 14	Conveying Systems					
Division 15	Mechanical					
Division 16	Electrical					
	Subtotal					
	GC General Conditions					
	GC Overhead & Profit					
	CQC Plan (Min. 3% of Subtotal)					
	GC Mobilize / De-Mobilize					
	GC Bonds					
	GC Insurance					
	Miscellaneous Allowance					
	Totals					

SP-10.08 Energized Equipment Work Permit (SP-4.17)

MARYLAND DEPARTMENT OF TRANSPORTATION MARYLAND AVIATION ADMINISTRATION

ENERGIZED EQUIPMENT WORK PERMIT

I. GENERAL INFORMATION	
Date	
Contractor Company Name	
Contract/Building Permit No.	
Contract/Building Permit Title	
Description of circuit/equipment	
Description of proposed work	

II. TO BE COMPLETED BY CONTRACTOR	
1) Date and Time of Proposed Work	
2) Location of Proposed Work (Attach exhibit of Floor Plan)	
3) Detailed description of proposed work to be done including description of procedure to be used in performing work	
4) Justification of why the circuit/equipment cannot be de-energized for the proposed work	
5) Description of the safe work practices to be employed	
6) Shock Risk Assessment	
a) Voltage to which personnel will be exposed:	
b) Limited approach boundary:	
c) Restricted approach boundary:	
d) Necessary shock, personal, and other protective equipment to safely perform work:	
7) Arc Flash Risk Assessment	
a) Available incident energy at the working distance or arc flash PPE category:	
b) Necessary arc flash personal and other protective equipment to safely perform work (If Arc flash label/ incident energy level label is not present, the contractor must take all necessary precautions for safety in accordance with the current applicable codes and standards):	
c) Arc flash boundary:	
8) Means employed to restrict the access of unqualified persons from work area	

9) Name of Electrically Qualified Person performing proposed work	
II.a. CONTRACTOR SIGNATURE	
Requestor's Name and Title (Printed)	
Requestor's Signature	Date
I have reviewed and agree that the above described work can be done safely.	
Safety Manager Signature	Date

III. APPROVAL BY CMI REPRESENTATIVE	
Engineer's Name and Company (Printed)	
Engineer's Signature	Date

IV. APPROVAL (FOR MAA USE ONLY)	
MAA Office of Facilities Maintenance Approver Name (Printed)	
MAA Office of Facilities Maintenance Approver Signature	Date

PART II

**Contractor Affirmative Action Program
and
Equal Employment Opportunity (EEO)
Programs**

SECTION 1 OVERVIEW

AAP-1.01 General

- A. Contractors shall cooperate with the Maryland Aviation Administration (Administration) in carrying out its EEO obligations and in the Administration's review of Contractor's activities performed under this contractual agreement.
- B. Contractors shall comply with the Governor's Code of Fair Practices, (Governor's Executive Order 01.01.1995.19). Contractors shall include these requirements in every subcontract with such modifications of language as is necessary to make these provisions binding on the subcontractor.
- C. Contractors shall comply with the Code of Maryland Regulations (COMAR), Title 21, State Procurement Regulations.
- D. Contractors shall comply with Maryland Department of Transportation (MDOT) Minority Business Enterprise (MBE) Program requirements.

AAP-1.02 Applicability

- A. The Administration's Contractor Affirmative Action/EEO Program requirements are applicable to all Contractors doing business with the Administration.
- B. The Administration's MBE Program requirements are applicable to construction contracts in excess of \$100,000.
- C. The Administration's MBE program requirements are applicable to the procurement of supplies, services, and maintenance in excess of \$50,000.

SECTION 2

AFFIRMATIVE ACTION/EQUAL OPPORTUNITY PROGRAM

AAP-2.01 Definitions

- A. Affirmative Actions - Efforts exerted toward achieving EEO through positive, aggressive, continuous results-oriented measures to correct past and present discriminating practices and their effects on conditions/privileges of employment.
- B. Contractor/Subcontractor - Individual, partnership, firm or corporation undertaking execution of work under contract terms acting directly or through agents/employees.
- C. Corrective Action - Contractors written, signed commitment outlining specific action to be taken with time limits, goals, etc., to correct violation of EEO regulations.
- D. Discrimination - Distinction in treatment, whether intentional/unintentional, based on political, religious opinion/affiliation, race, color, creed, national origin, sex, physical/mental disability, age, except where sex, disability or age involves a bona fide job requirement.
- E. Equal Employment Opportunity Officer - Designated employee of Contractor whose responsibility it shall be to implement and maintain the Affirmative Action Plan.
- F. Good Faith Effort - Documented efforts on the part of a bidder/contractor that were intensive, aggressive and of a sincere nature for a specific project far beyond a simple paperwork exercise.
- G. Personnel Actions - All decisions respecting employment including, but not limited to, hiring, upgrading, demotion, transfer, recruitment or advertising, layoff or termination, rates of pay or other forms of compensation, and selection for training to include apprenticeship, pre-apprenticeship or on-the-job training.

AAP-2.02 Legal Mandates

- A. Title VI, Civil Rights Act of 1964 prohibits discrimination based on race, color, or national origin in all programs and activities which receive Federal Financial Aid. Employment discrimination is prohibited if primary purpose of Federal assistance is a provision of employment, e.g. apprenticeship, training, or similar programs. Revised 1973 guidelines prohibit discriminatory employment practices in programs if

such practices cause discrimination in services provided to beneficiaries of the program.

- B. Title VII, Civil Rights of 1964 (as amended by the EEO Act of 1972). Title VII prohibits discrimination because of race, color, religion, sex, national origin, in any term, condition, or privilege of employment.
- C. Executive Order 11246 (as amended). Order issued by President in 1965 requires EEO/Affirmative Action Programs by all Federal Contractors/subcontractors. It also requires firms with contracts over \$50,000 and 50 or more employee develop/ implement written programs, which shall be monitored by the Federal Office of Contract Compliance. Specific requirements for such result-oriented programs are identified in Revised Order #4, issued by the Federal Office of Contract Compliance US Department of Labor. Requirements include identifying areas of minority/female under-utilization, numerical promotional, hiring goals, and other actions to increase minority employment in classifications where they are currently under-utilized.
- D. The Age Discrimination Act of 1967 prohibits employers of 25 or more persons from discriminating against persons 40-65 years of age in employment due to age.
- E. National Labor Relations Act of 1935. Discrimination on the basis of race, religion, sex, or national origin constitutes an unfair labor practice under this Act. It shall be unlawful for employers to participate with unions in the commission of any discriminatory practices under this Act, or to practice discrimination in a manner, which gives rise to racial, or other division, amongst employees to the detriment of organized union activity. It is unlawful for unions to exclude individuals discriminatorily from union memberships, which cause them to lose job opportunities, discriminate in the representation of union members or non-members in collective bargaining, in processing or grievance, or in any other respect, which may cause or attempt to cause employers to enter into discriminatory agreements, or otherwise discriminate against members and non-members.
- F. Governor's Code of Fair Practices for the State of Maryland (Amended). The Governor of Maryland issued a revised Code of Fair Practices which was promulgated July 1988 as the Governor's Executive Order 01.01.1995.19, in recognition of the State's responsibility to root out evils of discrimination based on race, color, creed, national origin, sex, and age. This Code was amended to be in compliance with Federal mandates regulating laws pertinent to EEO/Affirmative Action.
- G. Rehabilitation Act of 1973 (Public Law 93-112). Law provides a statutory basis for Rehabilitation Services Administration to authorize programs to promote/expand employment opportunities in public and private sectors for handicapped individuals.

- H. Section 13-219, State Finance and Procurement Article, Annotated Code of Maryland provides for non-discrimination in State construction contracts subcontracts. Provision obligates Contractor not to discriminate in any manner against any employee or applicant for employment because of race, creed, color, or national origin and obligates subcontractors to same.
- I. Other Laws. Employment discrimination has also been ruled by courts to be prohibited by the civil Rights Acts of 1866 and 1870, the equal protection clause of the Fourteenth Amendment of the Constitution of the United States, and the Equal Pay Act of 1963. Action may be taken on behalf of individuals or groups, private organizations, trade unions, or other groups, under these laws.

AAP-2.03 Assignment of Responsibilities

- A. Contractor shall designate an EEO Officer, whose responsibilities shall include implementing Affirmative Action Plan, coordinate, advise, assist management, and key officials, render periodic reports to responsible executives relative to progress, and make appropriate recommendations along these lines to executives of project.
- B. The name of the EEO Officer, telephone number, and address where he/she can be reached concerning any acts or alleged acts of discrimination, shall be posted on the bulletin board at the home office as well as on the bulletin boards on all job-sites.

AAP-2.04 Dissemination of Policy

The Contractor shall take appropriate steps to insure that all employees are advised of its policy of non-discrimination and of its interest in actively and affirmatively providing equal employment opportunity for all citizens. The steps include:

- A. Periodic meetings of supervisory and personnel office employees to be conducted at least every 6 months so that the EEO policy and plan may be revised and explained.
- B. All new supervisory and personnel office employees are to be made aware of the EEO policy and plan as soon as practicable, but certainly within 30 days following the date of entry for duty.
- C. Contractor shall make EEO policy known to all employees, prospective employees, and potential sources of employees, through schools, employment agencies, labor unions, college placement officers, etc., by taking the following actions:

1. Notices and posters setting forth the EEO policy shall be placed in areas readily accessible to employees and applicants for employment.
4. The EEO policy and the procedures for implementing the EEO policy shall be brought to the attention of employees through meetings, employee handbooks, or other appropriate means.

AAP-2.05 Recruitment

- A. Contractor shall include in all advertising the following notation: "An Equal Opportunity Employer". Contractor shall insert all advertisements in newspapers or publications having large circulation among minorities/females in area from which the project work is derived.
- B. Contractor shall, unless precluded by valid collective bargaining agreement, conduct systematic, direct recruitment through public and private employee referral sources likely to yield qualified minority/female applicants, including, but not limited to, State employment agencies, school, college, minority/female organizations, i.e., the Urban League, NAACP, etc. To meet this requirement, we shall identify sources of potential minority/female employees and establish such sources procedures whereby minority/female applicants may be referred to us for employment consideration
- C. Contractor shall develop procedures for promoting employment of minority/ female youth on an after-school, summer, and vacation basis, to the extent possible.
- D. Contractor shall encourage its employees to refer minority/female applicants for employment by posting appropriate notices or bulletins in areas accessible to all such employees. In addition, information and procedures with regard to referring minority/female applicants shall be discussed with employees.

AAP-2.06 Personnel Actions

To avoid discrimination in personnel actions, the following procedures shall be followed:

- A. Contractor shall conduct periodic inspections of project sites to insure that working conditions and employee facilities do not indicate discriminatory practices.
- B. Contractor shall periodically evaluate the spread of wages paid within each classification to determine any evidence of discriminatory wage practices.
- C. Contractor shall periodically review personnel actions in depth to determine whether there is any evidence of discrimination. Where evidence is found, prompt corrective action shall be taken immediately.
- D. Contractor shall investigate all complaints of alleged discrimination and attempt to

resolve such complaints. Additionally, if the investigation indicates that the discrimination may affect persons other than complainant, appropriate corrective actions shall include other persons. Upon completion of each investigation, each complainant shall be informed of all avenues of appeal.

AAP-2.07 Training and Promotion

To eliminate discrimination in training and promotion, the following actions shall be taken:

- A. Contractor shall assist in locating, qualifying, and increasing the skills of minority/female employees and applicants for employment.
- B. Consistent with employment requirements and permissible under State regulations, full use shall be made of training programs, i.e., pre-apprenticeship, apprenticeship, and on-the-job training programs for the geographical area of contract performance.
- C. Contractor shall advise employees and applicants for employment of available training programs and entrance requirements for the programs.
- D. Contractor shall periodically review training/promotional potential of minority/female employees and encourage eligible employees to apply for training/promotions.

AAP-2.08 Utilization of Unions

This section deleted in its entirety.

AAP-2.09 Utilization of Subcontractors

- A. Contractor shall use good faith efforts to employ subcontractors whose employees reflect minority/female groups approximately equal to the number available in the current labor pool population, or owned by a minority/female.
- B. Contractor shall use good faith efforts to assure all subcontractors comply with EEO obligations as defined in the amended Governor's Code of Fair Practices.

AAP-2.10 Records and Reports

- A. In accordance with the Governor's Code, Article III, Section A&C(2), Contractor shall keep such records as are necessary to determine compliance with EEO obligations. The records kept shall be designed to indicate:

1. Number of minority/female and other persons employed in each work classification of the project.
 2. Progress/efforts being made in cooperation with unions, if any, to increase minority/female employment opportunities.
 3. Progress/efforts being made in locating, hiring, training, qualifying, and upgrading minority/female employees.
 4. Progress/efforts made to secure services of minority/female subcontractors.
- B. All such records shall be retained for a period of three years following completion of the contract work and shall be available at reasonable times and places for inspection by authorized representatives of the Administration.
- C. Contractor shall submit to the Administration a monthly report for the first three months after the contract begins and thereafter, upon request of the Administration for the duration of the project. Report shall indicate number of minority/female employees currently engaged in each work classification.

AAP-2.11 Monitoring

This Section is deleted in its entirety.

AAP-2.12 Employment Goals and Timetables for Minority and Female Utilization in All Trades

For a project performed in any region addressed below, the following goals and timetables, as appropriate, for minority and female utilization shall be applicable. The total distribution of work hours (actual work hours performed on the job) for minorities and females shall be consistent with the following utilization goals for minorities and females, respectively, and shall apply to all trades.

REGION	DESCRIPTION	UTILIZATION GOALS		TIMETABLE
		MINORITY	FEMALE	
1 Baltimore Metropolitan SMSA	This area includes Anne Arundel, Baltimore, Carroll, Harford, Howard Counties, and Baltimore City.	23.0% - 27.5%	6.9%	October 1, 1989 to September 30, 1995
2 Eastern Shore Maryland NON-SMSA	This area includes Caroline, Dorchester, Kent, Queen Annes, Somerset, Talbot, Wicomico and Worcester Counties.	28.3% - 27.5%	6.9%	October 1, 1989 to September 30, 1995
3 Southern Maryland NON-SMSA	This area includes Calvert, Frederick, Washington and St. Mary's Counties.	25.2%	6.9%	October 1, 1989 to September 30, 1995
4 Washington, D.C. Metropolitan SMSA	This area includes Charles, Montgomery and Prince Georges Counties.	28%	6.9%	October 1, 1989 to September 30, 1995
5 Western Maryland NON-SMSA	This area includes Allegheny and Garrett Counties.	4.8%	6.9%	October 1, 1989 to September 30, 1995
6 Wilmington, Delaware SMSA	This area includes Cecil County only.	12.3%	6.9%	October 1, 1989 to September 30, 1995

PART III

**Maryland
Minority/Disadvantaged
Business
Enterprise Program**

SECTION 1 PROGRAM AUTHORITY

MBE-1.01 Program Authority

- A. Statutory and regulatory mandates of the State of Maryland do not provide for the use of Minority Business Enterprise Program "set-asides" to achieve minority business enterprise program participation. Instead, the Maryland General Assembly has mandated a goal oriented program to achieve minority participation in the state's procurement activities.
- B. The Maryland Department of Transportation (MDOT) Disadvantaged Business Enterprise Program (DBE), as mandated by Federal regulations 49 CFR Part 26 and the State's Minority Business Enterprise Program (MBE), must meet certain statutory and regulatory requirements as a condition of law and federal funding requirements. Those statutory and regulatory requirements are as follows:
1. 49 CFR, Part 26, Subparts A through F for all applicable Federal Department of Transportation Financial Assistance Programs. This regulation requires both a Program goal and a Contract goal. For the purposes of this Program, goals shall be set for specific contracts based on the known availability of certified DBE/MBEs. MDOT establishes an overall program goal each year for disadvantaged businesses.
 2. Intermodal Surface Transportation Efficiency Act of 1991 (ISTEA). This act replaces the Surface Transportation and Uniform Relocation Assistance Act of 1987, which provides that, except to the extent that the U.S. DOT Secretary determines otherwise, not less than 13 percent of the amounts authorized to be appropriated under this act shall be expended with small business concerns owned and controlled by socially and economically disadvantaged individuals.
 3. Transportation Equity Act of 1998 (TEA-21). This act replaces the Intermodal Surface Transportation Efficiency Act of 1991 (ISTEA) which provides that, except to the extent that the U.S. DOT Secretary determines otherwise, not less than 10 percent of the amounts authorized to be appropriated under this act shall be expended with small business concerns owned and controlled by socially and economically disadvantaged individuals.
 4. Title 14, Subtitle 3 of the State Finance and Procurement Article of the Annotated Code of Maryland for all Straight State Construction Contracts.

“as amended effective July 1, 2001.” For MDOT Construction contracts in excess of \$50,000.00, this statute requires MDOT to structure procurement procedures to attempt to achieve the following results:

- a. Participation by Certified Minority Business Enterprises classified as African American-owned in an amount that is at least 7% (percent) of the dollar value of construction contracts;
 - b. Participation by Certified Minority Business Enterprises classified as Women-owned in an amount that is at least 10% (percent) of the dollar value of construction contracts; and
 - c. Overall participation by all certified Minority Business Enterprises in an amount that is at least 25% (percent) of the dollar value of construction contracts.
5. Title 10, Subtitle 3 of the State Finance and Procurement Article of the Annotated Code of Maryland for Leases of State-Owned Property. This statute requires a goal of 10 percent MBE participation in the leasing of State-Owned property to business entities. The statute requires State agencies that lease State-owned property to structure procedures to try to achieve participation by minority business enterprises in: (1) 10 percent of the total dollar amount of the leases; and (2) 10 percent of the total number of leases.
6. Title 14, Subtitle 3 of the State Finance and Procurement Article of the Annotated Code of Maryland. This statute requires the Board of Public Works under section 14-303 of the subtitle to designate one agency to certify and decertify minority business enterprises for all units of State government through a single process that meets applicable Federal requirements. MDOT has been designated by the Board of Public Works to be that agency.
- C. FEDERAL REQUIREMENTS. To the extent required by Federal assistance instruments applicable to contracts let by the State under a Federal assistance program, only those DBE/MBEs meeting federal requirements and criteria shall be used.
- D. The Department of Transportation advises each subrecipient (local agencies receiving federal funds from the State), that they are required to include the following provision in all agreements with contractors on projects utilizing Federal funds:
1. Disadvantaged Business Enterprises:

- a. Policy. It is the policy of the United States Department of Transportation that Disadvantaged Business Enterprises, as defined in 49 CFR, Part 26, shall have the maximum opportunity to participate in the performance of contracts financed in whole or in part with Federal funds under this Agreement. Consequently, the DBE/MBE requirements of 49 CFR, Part 26, apply to this Agreement.
- b. DBE/MBE Obligation. The Contractor agrees to ensure that disadvantaged business enterprises, as defined in 49 CFR, Part 26, have the maximum opportunity to participate in the performance of contracts and subcontracts financed in whole or in part with Federal funds provided under this Agreement. In this regard, all contractors shall take all necessary and reasonable steps in accordance with 49 CFR, Part 26, to ensure that disadvantaged business enterprises have the maximum opportunity to compete for and perform contracts. Contractors shall not discriminate on the basis of race, color, national origin or sex in the award and performance of contracts assisted by the United States Department of Transportation.

E. The MDOT DBE/MBE Program also contains procedures and Special Bid Provisions which are to be included in all bid documents and appropriate contracts to assure conformance with applicable requirements. Interested parties may view these documents and Special Bid Provisions upon request by contacting the Maryland Department of Transportation, Office of Minority Business Enterprise, during normal business hours.

F. Each financial assistance agreement between Maryland Department of Transportation (MDOT) and a U.S. DOT operating administration must include the following assurance:

1. The recipient shall not discriminate on the basis of race, color, national origin, or sex in the award and performance of any DOT-assisted contract or in the administration of its DBE program or the requirements of 49 CFR Part 26. The recipient shall take all necessary and reasonable steps under 49 CFR Part 26 to ensure nondiscrimination in the award and administration of DOT-assisted contracts. The recipient's DBE program, as required by 49 CFR Part 26 and as approved by DOT, is incorporated by reference in this agreement. Implementation of this program is a legal obligation and failure to carry out its terms shall be treated as a violation of this agreement. Upon notification to the recipient of its failure to carry out its approved program, the Department may impose sanctions as provided for under Part 26 and may, in appropriate cases, refer the matter for enforcement under 18 U.S.C.

1001 and/or the Program Fraud Civil Remedies Act of 1986 (31 U.S.C. 3801 *et seq.*).

SECTION 2 EXPLANATION OF TERMS

MBE-2.01 Explanation of Terms

The following explanation of terms have been provided to insure proper interpretation of key words and terms associated with the MDOT DBE/MBE Program.

Act -- The Surface Transportation and Uniform Relocation Assistance Act of 1987 (Public Law 100-17), Intermodal Surface Transportation Efficiency Act of 1991, and Transportation Equity Act of 1998 (TEA-21).

Administration -- Any one of the Administrations within the Maryland Department of Transportation (Maryland Aviation Administration, Maryland State Highway Administration, Maryland Port Administration, Mass Transit Administration, Motor Vehicle Administration, Maryland Transportation Authority and the Office of the Secretary).

Administrative Representative-- A DBE/MBE Officer or employee of an Administration who enforces the laws and regulations pertaining to disadvantaged and minority business enterprise and contract compliance.

Administrative Law Judge-- An official of the State Office of Administrative Hearings who has been delegated the authority to preside over contested decertification hearings.

Administrator -- The chief executive of an Administration who is charged with the implementation of the DBE/MBE Program for his/her individual administration.

Affirmative Actions-- Specific steps taken to eliminate discrimination and its effects, to ensure nondiscriminatory results and practices in the future, and to involve disadvantaged and minority business enterprises fully in contracts and programs funded by the MDOT.

Annual Receipts (also Gross Receipts)-- For the purpose of determining annual receipts of a business concern, the Maryland Department of Transportation is incorporating into this manual by reference 13 CFR, Part 121 Section 121.402 Annual Receipts.

Applicant -- A business which has applied to the MDOT for certification as a bona fide DBE/MBE.

Chair/MBEAC -- The Director of the Office of MBE, the Deputy Director of the Office of MBE, or other person designated to preside over meetings of the Minority Business Enterprise Advisory Committee.

Commercially Useful Function-- Work performed by a DBE/MBE in a particular transaction can be counted towards goals only if the Administration determines that it involves a commercially useful function. A certified business is considered to perform a commercially useful function when it is responsible for the execution of a distinct element of the work of a contract and carries out its responsibilities by actually performing, managing and supervising the work involved. That is, in light of industry practices and other relevant considerations, the DBE/MBE must have a necessary and useful role in the transaction of a kind for which there is a market outside the context of the DBE/MBE Program. The firm's role cannot be a superfluous step added in an attempt to obtain credit goals.

Commission-- Represents monies charged for commercially useful and bona fide services. (Fee)

Consultant -- See Contractor/Subcontractor

Contract Compliance Officer-- The Department employees who are responsible for monitoring MDOT contracts for compliance with Federal DBE and State regulations regarding nondiscrimination in MDOT's DBE/MBE Program.

Contractor/Subcontractor-- One who participates through a prime contract, second tier subcontract,¹ or lease agreement, in any matter covered by this Program.

Control -- The power of the business owner(s) to direct the management and operation of a business enterprise. (See Operational Control and Managerial Control).

Corporation -- An artificial person or legal entity created by or under the authority of the laws of any state of the United States, the District of Columbia or a territory or commonwealth of the United States and formed for the purpose of transacting business in the widest sense of that term, including trade, commerce, manufacturing, mining, banking, insurance, transportation and other forms of commercial or industrial activity where the purpose of the organization is profit. For eligibility for certification, disadvantaged and/or minority individuals must own at least 51 percent of each class of the voting stock and at least 51 percent of the aggregate of all classes of stock that have been issued by the corporation.

Day -- Any day: workday, weekend or legal holiday.

¹See third tier contract

Department-- The Maryland Department of Transportation.

DBE Business Development Program-- A support program included in U.S. DOT 49 CFR Part 26 designed to move DBEs into non-traditional work areas, strengthen their ability to compete or in other ways assist the growth of DBEs by receiving assistance from MDOT. (See the DBE Business Development Guidelines in the Attachments to this Manual.)

DBE/MBE Program -- A program developed by MDOT to implement the requirements of Title 14, Subtitle 3 of the State Finance and Procurement Article, Annotated Code of Maryland; Title 10, Subtitle 3 of the State Finance and Procurement Article of the Annotated Code of Maryland for Leases of State-Owned Property; and 49 CFR, Part 26, Subparts A and C for all Federal Department of Transportation Financial Assistance Programs.

Disabled-- A condition describing a person who has a physical or mental impairment that substantially limits one or more major life activity. Major life activity may include caring for one's self, performing manual tasks, walking, seeing, hearing, speaking, breathing or learning. The disability is of a nature that it permanently limits a person (or his/her firm) from obtaining contracts. A person with a disability must be able to demonstrate that: (1) he/she has a history of the disability; (2) he/she is generally regarded as having such disability; and (3) the disability has substantially limited his/her ability to engage in competitive business.

Fee -- A fee is money charged for providing a commercially useful and bona fide service. (Commission)

Goal -- An Overall Annual Program Goal is established each year as an aspirational goal. Contract goals are established for each specific contract based on specific factors affecting such goals. An Overall Goal under 49 CFR Part 26 is established each year for each of the State Highway Administration, the Mass Transit Administration and the Maryland Aviation Administration. These are discussed in greater detail within this Manual.

The MDOT DBE/MBE program goal is set annually. A contract goal may be higher or lower than a program goal. When an Administration establishes contract goals, the following will be used as goal determining factors:

1. Items of work which feasibly and reasonably can be contracted;
2. Availability of certified businesses within a reasonable geographical area in which the contract is to be performed; and
3. Contracts which hold the greatest business potential for the minority business enterprise community.

The Administration responsible for the contract must consider factors such as these prior to advertising the goal(s) in bid advertisements.

The Prime contractor may compute 60 percent of the purchase of supplies from regular dealers who are DBEs/MBEs toward the contract goal. Supplies may not exceed 60 percent of the entire contract goal.

Good Faith Efforts-- Efforts to achieve a DBE/MBE goal which, by their scope, intensity and appropriateness to the objective, can reasonably be expected to fulfill the program requirement.

Graduation -- State Program - The process by which a certified firm is deemed to be no longer eligible to participate in the State MBE Program due to its 3 year average of gross annual revenues or annual employment total.

Gross Revenue-- Same as Annual Receipts/Gross Receipts

Home-State Certification-- A DBE/MBE certification held by an out-of-state applicant, which certification has been granted by a governmental agency located within the state in which the applicant has its principal place of business. Home-State Certification is a prerequisite for MDOT certification for any firm with its principal place of business located outside of Maryland.

Hotline-- A 24 hour toll free telephone number direct to the Office of MBE, Maryland Department of Transportation.

In-State Firm-- A firm that has its principal place of business in the State of Maryland.

Joint Venture -- An association of a DBE/MBE firm and one or more other firms to carry out a single, for-profit business enterprise, for which the parties combine their property, capital, efforts, skills, and knowledge, and in which the DBE/MBE is responsible for a distinct, clearly defined portion of the work of the contract and whose share in the capital contribution, control, management, risks, and profits of the joint venture are commensurate with its ownership interest.

Lessee -- A business or a person who leases, or is negotiating to lease, property from the MDOT or the U.S. DOT on a MDOT or a U.S. DOT facility for the purpose of operating a transportation-related activity or for the provision of goods or services to a facility or to the public on a facility.

Manufacturer -- A firm that produces a product from raw materials or substantially alters a previously manufactured product by operating or maintaining a factory or establishment that produces or alters on the premises.

Manufacturer Representative -- A business that transfers title of a product from a manufacturer to an ultimate purchaser (e.g., a sales representative who invoices a product from the producing company to the contractors).

Mentor Protégé Program -- A support program included in 49 CFR Part 26 designed to move DBEs into non-traditional work areas and strengthen their ability to compete outside of the DBE Program by receiving assistance from other firms. This is not required as a part of the DBE Program. (See the Mentor-Protege Guidelines in the Attachments to this Manual.)

MDOT Director, Office of Minority Business Enterprise -- The individual designated by the Secretary of the Maryland Department of Transportation as responsible for management of the Office of Minority Business Enterprise, this includes the certification process and the policy development of the Socially and Economically Disadvantaged and Minority Business Program.

Minority Business Enterprise (MBE)

1. Straight State Contracts:

Any legal entity, other than a joint venture, organized to engage in commercial transactions which is at least 51 percent owned and controlled by one or more minority persons, or a non-profit entity organized to promote the interests of the physically or mentally disabled.

2. Federal-Aid Contracts under 49 CFR, Part 26, Subpart A through F:

- a. A small business concern as defined pursuant to Section 3 of the Small Business Act (15 USC 637)(a) and implementing regulation (49 CFR, Part 26), which is owned and controlled by one or more economically and socially disadvantaged persons. For the purposes of the Program, owned and controlled means a business:
- b. Which is at least 51 percent owned by one or more minority or socially and economically disadvantaged persons. Where stock ownership is involved, the disadvantaged owner(s) must own at least 51 percent of each class of the voting stock and at least 51 percent of the aggregate of all classes of stock that have been issued (also applies to publicly owned businesses); and
- c. Whose management and daily business operations are controlled by one or more socially and economically disadvantaged or minority persons.

Minority or Minority Person

1. Straight State Contracts:

- a. A member of one of the following socially and economically disadvantaged minority groups:
 - 1) African American - An individual having origins in any of the Black racial groups of Africa;
 - 2) American Indian/Native American - An individual having origins in any of the original peoples of North America and who is a documented member of a North American tribe, band, or otherwise organized group of native people who are indigenous to the continental United States or who otherwise have a special relationship with the United States or a state through treaty, agreement, or some other form of recognition. This includes an individual who claims to be an American Indian/Native American and who is regarded as such by the American Indian/Native American community of which he/she claims to be a part, but does not include an individual of Eskimo or Aleutian origin;
 - 3) Asian - An individual having origins in the far East, Southeast Asia, or the Indian Subcontinent and who is regarded as such by the community of which the person claims to be a part;
 - 4) Hispanic - A person of Mexican, Puerto Rican, Cuban, Central or South American, Portuguese or other Spanish culture or origin, regardless of race, and who is regarded as such by the community of which the person claims to be a part;
 - 5) Women - This category shall include all women, regardless of race or ethnicity, although a woman who is also a member of an ethnic or racial minority group may elect that category in lieu of the gender category; or
 - 6) Physically or Mentally Disabled - see Explanation of Term "Disabled".

2. Federal-Aid Contracts under 49 CFR, Part 26, see Explanation of Terms "Socially and Economically Disadvantaged Individual".

North American Industrial Classification System (NAICS) -- A code established by the federal government to categorize all economic activities in the U.S. by product or service. All certified firms are certified in particular areas of work categorized by Standard Industrial Classification, a system replaced in 1999 by the NAICS.

Operation Guaranteed Help -- MDOT special assistance for the DBE/MBEs certified by MDOT who need business assistance. The certified firm's owner can call the MBE Hotline at 1-800-544-6056 and a business consultant will respond within 24 hours, to understand the issues/questions and make arrangements to meet with the owner, at no cost to the DBE/MBE.

1. Assistance includes, but is not limited to, the following:
 - a. Office procedures
 - b. Maintaining records
 - c. Bidding techniques
 - d. Estimating techniques
 - e. Work programming
 - f. Any technical problems
 - g. Practical ways of getting a job done
 - h. Bonding
 - i. Insurance
 - j. Other questions or concerns.

Out-of-State Firm -- A firm whose principal place of business is in a state or location other than Maryland.

Overconcentration -- A market condition described in 49 CFR Part 26 in which the number of DBEs and their business activities in an area of work causes an undue economic burden to non-DBE firms who participate in this area of work.

Ownership -- See Section on Eligibility.

Personal Net Worth -- The net value of the assets of an individual remaining after total liabilities are deducted. An individual's personal net worth does not include: the individual's ownership interest in an applicant or participating DBE firm or the individual's equity in his or her primary place of residence. An individual's personal net worth includes only his or her own share of assets held jointly or as community property with the individual's spouse.

Primary Industry Classification -- The four digit Standard Industrial Classification (SIC) code designation which best describes the primary business of a firm. The SIC code designations are described in the Standard Industry Classification Manual. As the North American Industrial Classification System (NAICS) replaces the SIC system, references to SIC codes and the SIC Manual are deemed to refer to the NAICS Manual and applicable codes. The SIC Manual and the NAICS Manual are available through the National Technical Information Service (NTIS) of the U.S. Department of Commerce (Springfield, VA, 22261). NTIS also makes materials available through its web site (www.ntis.gov/naics).

Reduced Candidate List -- A list of businesses established by the Department's consultant screening committee through screening and evaluation of candidate businesses pursuant to MDOT Consultant Selection Guidelines, from which technical and price proposals are requested.

Regular Dealer -- A firm that owns, operates, or maintains a store, warehouse, or other establishment in which the materials or supplies required for the performance of the contract are bought, kept in stock, and regularly sold to the public in the usual course of business. To be a regular dealer, the firm must engage in, as its principal business, and in its own name, the purchase and sale of the products in question. A regular dealer in such bulk items as cement, gravel, stone, and petroleum need not keep such products in stock, if it owns or operates distribution equipment. Brokers and packagers shall not be regarded as manufacturers or regular dealers within the meaning of this section.

A Regular Dealer must be engaged in selling the product in question to the public. This is important in distinguishing a Regular Dealer, which has a regular trade with a variety of customers, from a firm which performs supply-like functions on an ad hoc basis or for only one or two contractors with whom it has a special relationship.

A business that simply transfers title of a product from manufacturer to ultimate purchaser (e.g. broker or sales representative who re-invoices a product from the producing company to the recipient or contractor) or a firm that puts a product in a container for delivery would not be considered a Regular Dealer.

A supplier of bulk goods may qualify as a regular dealer if it either maintains an inventory or owns or operates distribution equipment. With respect to the distribution equipment (e.g. a fleet of trucks), the term "operates" is intended to cover a situation in which the supplier leases the equipment on a regular basis for its entire business. It is not intended to cover a situation in which the firm simply provides drivers for trucks owned or leased by another party, (e.g., a prime contractor) or leases such a party's trucks on an ad hoc basis for a specific job.

Secretary - The Secretary of The Maryland Department of Transportation, or his/her designated representative.

Size Eligibility Provisions and Standards -- For the purpose of determining size eligibility of a business concern to participate as a DBE/MBE, the Maryland Department of Transportation is incorporating into this manual by reference 13 CFR, Part 121 Subpart A Size Eligibility provisions and standards. Size standards are established by SIC Code (or NAICS Code) based on dollar amounts or number of employees. Size determinations are based on a three year average of annual gross receipts or number of employees in the preceding 12 months including affiliates of the firm, as that term is defined in 13 CFR Part 121.

Small Business Administration (SBA) 8(a) Certification -- The SBA 8(a) Certification Program is a Federal Program which establishes firms as disadvantaged and eligible for participation in the Federal SBA Program.

Small Business Concern -- For a federally aided project, a small business as defined in to Section 3 of the Small Business Act and regulations promulgated pursuant thereto. The criteria for a determination of whether a business is a small business concern shall follow those published and promulgated by the U.S. Small Business Administration. The standards for small business size are incorporated in this manual by reference.

Standard Industrial Classification (SIC) -- The Code established by the federal government to categorize all economic activities in the U.S. by product or service. All certified firms are certified in particular areas of work as categorized by SIC Codes with necessary describing language. The Federally established size standards used for participation in the MBE/DBE Program have been established by individual SIC Codes. The North American Industrial Classification System (NAICS) replaces the SIC Codes beginning in 1999.

Straight State Contract -- Any contract or modification of a contract that is fully funded by the State of Maryland, including a contract funded by a combination of State and local government funds.

Subcontractor -- One who has contracted with a prime contractor for the performance of all or part of the work or services which the prime contractor has a contract with MDOT to perform.

Supplier-- A regular dealer, who owns, operates, or maintains a store, warehouse, or other establishment in which the materials or supplies required for the performance of a contract are placed, kept in stock, and regularly sold to the public in the usual course of business. The supplier must perform a commercially useful function consistent with normal industry practices. To be a regular dealer, the firm must engage in, as its principal business, and in its own name, the purchase and sale of the products in question. A supplier of bulk goods (cement, gravel, stone, petroleum products) may qualify as a regular dealer if it either maintains an

inventory or owns or operates distribution equipment. With respect to the distribution equipment (a fleet of trucks), the term "operates" is intended to cover a situation in which the supplier leases the equipment on a regular basis for its entire business. It is not intended to cover a situation in which the firm simply provides drivers for trucks owned or leased by another party, (such as a prime contractor) or leases such a party's trucks on an ad hoc basis for a specific job.

Third Tier Contracting -- The process in which a prime contractor subcontracts a portion of an original contract to a subcontractor who in turn subcontracts a portion of a subcontract to a third party. This latter action is termed entering into a third tier contract. See Procedures For Contractor Compliance Process Section.

**SECTION 3
SPECIAL PROVISIONS AFFIRMATIVE ACTION
REQUIREMENTS UTILIZATION OF DBE/MBE FEDERAL AID
CONTRACTS**

MBE-3.01 Terms

- A. For the purpose of these requirements, the following terms as defined below shall apply:

Administration -- Any one of the Administrations within the Maryland Department of Transportation (MDOT) to include: Maryland Aviation Administration, Maryland State Highway Administration, Maryland Port Administration, Mass Transit Administration, Motor Vehicle Administration, Maryland Transportation Authority and the Office of the Secretary.

Administration Representative -- A DBE/MBE Officer or employee of an Administration who enforces laws and regulations pertaining to the Disadvantaged and Minority Business Enterprise Program.

Administrator -- The chief executive of an Administration who is charged with the implementation of the DBE/MBE Program for his/her administration.

Affirmative Actions -- Specific steps taken to eliminate discrimination and its effects, to ensure nondiscriminatory results and practices in the future, and to involve disadvantaged and minority business enterprises fully in contracts and programs funded by MDOT.

Business Enterprise -- Any for-profit legal entity which is organized in any form other than as a joint venture (e.g., sole proprietorship, partnership, corporation, etc.) to engage in lawful commercial transactions.

Certification -- The process by which a business is determined to be a bona fide DBE/MBE.

Certified Business -- A business which, by order of the Chair/MBEAC or his/her designee, has been certified as a bona fide DBE/MBE. MDOT certification does not equate to a pre-qualification status.

Contractor/Subcontractor -- One who participates, through a contract, subcontract, or lease agreement, in any matter covered by this program.

DBE/MBE Contract Goals -- The amount of a contract to be completed by certified businesses, i.e. DBEs, for federally financed contracts.

DBE/MBE Directory -- A compilation of disadvantaged or minority businesses which have been certified by MDOT as DBE/MBEs.

DBE/MBE Participation Program (also Plan) -- The documents submitted by the bidder or proposer pursuant to the appropriate special bid provisions. The Disadvantaged/Minority Participation Program will consist of the MDOT Schedule for Participation of DBE/MBEs (Form D-EEO-003), the MDOT Minority Contract Project Disclosure and Participation Statement (Form D-EEO-004), the MDOT Joint Venture Disclosure Affidavit (Form D-EEO-006) and the Minority Contractor Unavailability Certificate (Form D-EEO-005).

DBE/MBE – Disadvantaged/Minority Business Enterprise -- (Reference 49 CFR, Part 26, Subpart A) a small business concern: (1) which is at least 51 percent owned by one or more socially and economically disadvantaged individuals. Where stock ownership is involved, the disadvantaged owner(s) must own at least 51 percent of each class of voting stock and at least 51 percent of the aggregate of all classes of stock that have been issued (also applies to publicly owned businesses); and (2) whose management and daily business operations are controlled by one or more of the socially and economically disadvantaged individuals who have ownership.

Federal Aid Contract -- Any contract awarded to any contractor by the Maryland Department of Transportation, whose funds are derived in whole or in part from the U.S. DOT. This also includes consultant agreements, modification of contracts, and leases.

Joint Venture -- An association of a DBE/MBE firm and one or more other firms to carry out a single, for-profit business enterprise, for which the parties combine their property, capital, efforts, skills, and knowledge, and in which the DBE/MBE is responsible for a distinct, clearly defined portion of the work of the contract and whose share in the capital contribution, control, management, risks, and profits of the joint venture are commensurate with its ownership interest.

MDOT -- Maryland Department of Transportation.

MDOT Director, Office of Minority Business Enterprise -- The individual designated by the Secretary of the Maryland Department of Transportation, responsible for management of the Office of Minority Business Enterprise, the certification process and the policy development of the Disadvantaged/Minority Business Program.

Small Business -- A firm as defined pursuant to Section 8(a) of the Small Business Act and which does not exceed the maximum employee work force total or three

year average annual receipts, in accordance with the U.S. Small Business Administration size standards.

Small Business Administration (SBA) -- An agency of the federal government responsible for certifying a firm as a Section 8(a) firm.

Socially and Economically Disadvantaged Individual Pursuant to 49 CFR, Part 26 -- Those individuals who are citizens of the United States (or lawfully admitted permanent residents) and who are:

1. Found by MDOT to be socially and economically disadvantaged on a case-by-case basis;
2. Any individual in the following groups, members of which are rebuttably presumed to be socially and economically disadvantaged:
 - a. "Black Americans," which includes persons having origins in any of the Black racial groups of Africa;
 - b. "Hispanic Americans," which includes persons of Mexican, Puerto Rican, Cuban, Dominican, Central or South American, or other Spanish or Portuguese culture or origin, regardless of race;
 - c. "Native Americans," which includes persons who are American Indians, Eskimos, Aleuts, or Native Hawaiians;
 - d. "Asian-Pacific Americans," which includes persons whose origins are from Japan, China, Taiwan, Korea, Burma (Myanmar), Vietnam, Laos, Cambodia (Kampuchea), Thailand, Malaysia, Indonesia, the Philippines, Brunei, Samoa, Guam, the U.S. Trust Territories of the Pacific Islands (Republic of Palau), the Commonwealth of the Northern Marianas Islands, Macao, Fiji, Tonga, Kiribati, Juvalu, Nauru, Federated States of Micronesia, or Hong Kong;
 - e. "Subcontinent Asian American," which includes persons whose origins are from India, Pakistan, Bangladesh, Bhutan, the Maldives Islands, Nepal or Sri Lanka;
 - f. Women;
 - g. Any additional groups whose members are designated as socially and economically disadvantaged by the SBA, at such time as the SBA designation becomes effective.
3. Only those persons whose personal net worth does not exceed \$750,000 may be found to be economically disadvantaged.

MBE-3.02 Bidders' Action

- A. A bidder will seek certified DBE/MBEs for subcontracting for supplies and/or services, the combined value of which should equal or exceed the established goal of the contract.
- B. A bidder may count toward a DBE/MBE contract goal 60 percent (60%) of its DBE/MBE expenditures for supplies from a DBE/MBE supplier who is a regular dealer and who performs a commercially useful function in the supply process. DBE/MBE credited supplies may not exceed 60% of the entire contract goal.
- C. The bidder/proposer may count towards its DBE/MBE goal the expenditures of a certified DBE/MBE manufacturer up to a maximum of 100 percent (100%). A manufacturer is a firm that produces a product from raw materials or substantially alters a previously manufactured product by operating or maintaining a factory or establishment that produces a product on the premises.
- D. A manufacturer's representative is not considered a "Regular Dealer." A contractor would not receive credit based on a percentage of the cost of the product purchased from a manufacturer's representative. Only the fee received by the manufacturer's representative can be counted toward a DBE/MBE goal.
- E. Large supply items and fees must comply with provisions in **MBE-4.01** and **MBE-5.01 and MBE-5.02.**
- F. The apparent low bidder will be required to submit documentation indicating participation by certified disadvantaged businesses in a contract. The apparent low bidder shall submit to the Administration Representative the following information:
 - a. The name of an employee designated as the bidder's liaison officer for minority affairs;
 - b. A completed Schedule for Participation of Disadvantaged/Minority Business Enterprises (Form D-EEO-003), from among those whose names appear in the MDOT DBE/MBE Directory or who are otherwise certified by MDOT as being disadvantaged business enterprises;
 - c. A Minority Contractor Project Disclosure and Participation Statement (Form D-EEO-004), completed and signed by the prime contractor and the disadvantaged business enterprise for each business listed in the Schedule for Participation. This Statement and any amendments to the Participation Statement require the approval of the Administration;

- d. Where a bidder intends to achieve the contract goal for DBE/MBE participation by use of a joint venture, the bidder must submit a Joint Venture Disclosure Affidavit (Form D-EEO-006), showing the extent of DBE/MBE participation. If a bidder intends to use a joint venture as a subcontractor to meet its goal, the affidavit must be submitted through the bidder by the proposed subcontractors and signed by all parties;
 - e. Where the DBE/MBE Participation Program proposed does not meet the DBE contract goals, the bidder shall submit information sufficient to demonstrate that he/she has made good faith efforts to meet these goals. (See Good Faith Effort elsewhere in the MDOT DBE/MBE Manual)
- G. A DBE/MBE bidder has the same DBE/MBE requirements as a non-DBE/MBE bidder. (See 49 CFR §26.55).
- H. Determination of Bidder Responsibility for Federal-Aid Contracts:
If the bidder is unable to procure supplies and services equaling the specified contract goals, he/she shall request a waiver of the requirement in writing. A waiver of the DBE/MBE goal will be granted upon the determination of the bidder's good faith effort by the Administrator.
- I. Failure of a Bidder to Furnish Information or Otherwise Participate:
The apparent low bidder's failure to participate in any of these proceedings or failure to furnish information after written request may result in rejection of the bid and non-award of the contract to the apparent low bidder.
- J. The bidder will cooperate with the Administration Representative in any reviews of the contractor's procedures and practices with respect to certified businesses which the Representative may from time to time conduct.
- K. During the life of the contract, all plans to modify the approved DBE/MBE Participation Program will require the approval of the Administration. This will include all changes including items of work to be sublet or material and services obtained which differ from those considered in the original DBE/MBE Participation Program submittal.
- L. Contract Award
- a. Determination of DBE/MBE Bidder Responsibility for Federal-Aid Contracts -- Direct Procurement from DBE/MBE

Each firm desiring to furnish supplies or to perform a service in accordance with these special provisions, and who desires to be recognized as a bona fide DBE/MBE, must be certified as such by MDOT.
 - b. Determination by Administrator -- Subcontracting to DBE/MBEs

- 1) Based on the Administration Representative's evaluation and approval of a proposed DBE/MBE goal for a contract, the contract may be awarded to the successful bidder in accordance with this special procedure.
- 2) The apparent low responsive and responsible bidder will provide the Administration MBE Officer with the following items:
 - (a) A complete MDOT Schedule of Participation of Minority Business Enterprises (Form D-EEO-003);
 - (b) MDOT Minority Contractor Project Disclosure and Participation Statement (Form D-EEO-004);
- c. Waiver -- If, for any reason, a bidder or offeror is unable to achieve the established DBE/MBE goal, the bidder or offeror may request in writing, waiver of the goal with justification according to the procedures in this manual.
- d. Documentation -- The documents listed below will be considered a part of any contract and shall be furnished by the apparent low bidder or successful offeror to the Administration MBE Officer within ten (10) working days from notification that it is the apparent low bidder or successful offeror or within ten (10) working days following the award, whichever is earlier.
 - (1) A completed Schedule of Participation (Form D-EEO-003) naming each DBE/MBE who will participate in the project;
 - (2) A completed Minority Contractor Project Disclosure and Participation Statement (Form D-EEO-004);
 - (3) A written request for a waiver, if appropriate.
- e. If the contract has been awarded and the documents have not been furnished within the prescribed time, the award may be voided by the Administrator.

M. Request for Waiver of DBE/MBE Goal

- a. If, for any reason, the contractor is unable to meet the goals specified in the contract, the contractor will request, in writing, an exception to this requirement with justification to include the following:
 - (1) A detailed statement of the efforts made to contact and negotiate with DBE/MBEs including:

- (a) The names, addresses, dates and telephone numbers of DBE/MBEs who were contacted; and
 - (b) A description of the information provided to DBE/MBEs regarding the plans, specifications, and anticipated time schedule for portions of the work to be performed;
- (2) A detailed statement of the efforts made to select portions of the work proposed to be performed by DBE/MBEs in order to increase the likelihood of achieving the contract goal.

N. Amendment for Unforeseen Circumstances

If at any time before award, an apparent low bidder believes or has reason to believe that a DBE/MBE listed on its MDOT Schedule of Participation of DBE/MBEs is unable to perform or has become unqualified or unavailable, the low bidder will immediately notify the Administration's Representative. Within five (5) days, the apparent low bidder must make every reasonable effort to amend their DBE/MBE Participation Program if this is necessary to achieve the contract goal for DBE/MBE participation. Any amendments to the DBE/MBE Participation Program require the approval of the Administrator. Failure to make such efforts may result in a determination that the apparent bidder is not eligible for award of the contract.

O. Use of DBE/MBE Banks

The bidder shall consider, whenever possible, utilizing the services of DBE/MBE banks. Most DBE/MBE banks are full-service corporations that can provide an array of financial services such as Treasury and Tax Loan Fund Accounts, Time and Demand Deposit Accounts, Payroll Services, and if needed, organization investment counseling. It is the policy of MDOT to encourage its contractors to utilize, on a continuing basis, DBE/MBE banks.

MBE-3.03 Records and Reports

- A. The bidder shall submit such records as are required by the Administration to determine compliance with its DBE/MBE contract requirements. These records to be submitted by the bidder will include:
- 1. Documentation of all correspondence, contacts, telephone calls, e-mail, faxes, etc. to obtain services of DBE/MBEs on this project;
 - 2. For each subcontractor, DBE/MBE and non-DBE/MBE:
 - a. the nature of working being performed and/or materials supplied,

- b. contract amount and terms of performance and/or delivery,
 - c. copies of all canceled checks and corresponding invoices from subcontractors and suppliers, and
 - d. a record of all payments made to subcontractors and suppliers.
 - 3. The progress and efforts being made in seeking out DBE/MBEs for work on this project;
 - 4. Other information on firms bidding or being considered for subcontracting in accordance with 49 CFR Part 26, detailed elsewhere in this Manual.
- B. At least monthly, the bidder shall submit reports of contracts and other business transactions executed with DBE/MBEs with respect to the records referred to above, in such form, manner and content as prescribed by the MDOT. If the bidder cannot submit its report on time, it will notify the Administration's Representative and request additional time to submit the report. Failure of the bidder to report in a timely manner may result in a finding of non-compliance.
- C. All such records must be retained for a period of three years following completion of the contract work and shall be available for inspection by the U.S. Department of Transportation, Maryland Department of Transportation and the Administration awarding the contract.

MBE-3.04 Administrative Procedures for Enforcement

- A. Whenever the Administration believes the bidder or any subcontractor may not be operating in compliance with the terms of these provisions, the Administration's Representative will conduct an investigation. If the Administration's Representative finds the bidder or any subcontractor is not in compliance with these provisions, the contractor will be notified in writing of steps which will, in the judgment of the Administration, bring the contractor into compliance. If the contractor fails or refuses to take corrective action, the Administration's Representative will make a final report of non-compliance to the Administrator who may authorize the imposition of one or more of the sanctions listed below, in accordance with COMAR or 49 CFR Part 26:
- 1. Suspension of work on a project, pending correction;
 - 2. Withholding payment or a percentage thereof, pending correction;
 - 3. Referral of DBE/MBEs to MDOT Office of MBE for review for decertification and/or review/referral to the Attorney General's Office for review/initiation of

debarment or for review for criminal prosecution through the MDOT Office of General Counsel;

4. Initiation of suspension in accordance with COMAR regulations;
 5. Referral to the Attorney General's Office for review for debarment or for criminal prosecution through the MDOT Office of General Counsel;
 6. Any other action as appropriate.
- B. If the documents used to determine the status of a DBE/MBE contain false, misleading or misrepresenting information, the matter may be referred by the MDOT Office of General Counsel for appropriate action. In addition, when directed by the Administrator, the contractor will terminate, without liability to the Administration, its contract with a firm which, for any reason, is either no longer certified or no longer eligible to do business in the State. The program and all revisions require the Administrator's approval.

SECTION 4 CONTRACTOR COMPLIANCE

MBE-4.01 Contract Monitoring

- A. All MDOT compliance monitoring of all subcontractor participation will be conducted in accordance with the following:
1. Subcontractor Participation Reports: On a monthly basis, the contractor will be required to submit the subcontractor Participation Report which, at a minimum, shall include:
 - a. identification of the all subcontractors participating on the project;
 - b. type of work being done by each;
 - c. percentage of completion of work on project and of each subcontract;
 - d. dollar amount of project and each DBE/MBE contract;
 - e. actual monies paid during the reporting period and to date to the subcontractors;
 - f. work force roster of the prime contractor; and
 - g. comments by the contractor.
 2. Fees may be counted by a contractor towards its DBE/MBE goals for the following expenditures to DBE/MBE firms that are not manufacturers or regular dealers:
 - a. The fees or commissions charged for providing a *bona fide* service, such as professional, technical, consultant or managerial services and assistance in the procurement of essential personnel, facilities, equipment, materials or supplies required for performance of the contract, provided that the fee or commission is determined by MDOT to be reasonable and not excessive as compared with fees customarily allowed for similar services.
 - b. The fees charged for delivery of materials and supplies required on a job site (but not the cost of the materials and supplies themselves) when the hauler, trucker, or delivery service is not also the manufacturer of or a regular dealer in the materials and supplies,

provided that the fee is determined by MDOT to be reasonable and not excessive as compared with fees customarily allowed for similar services.

- c. The fees or commissions charged for providing any bonds or insurance specifically required for the performance of the contract, provided that the fee or commission is determined by MDOT to be reasonable and not excessive as compared with fees customarily allowed for similar services.
3. Third tier contracting is not the usual way for a prime contractor to achieve a DBE/MBE goal. However, MDOT realizes there may be rare occasions when third tier contracting would be acceptable. Two conditions must be met before an Administration may approve a third tier contracting arrangement which may be entered into to meet a DBE/MBE goal:
- a. The Administration awarding the contract must be satisfied that there is no way except by third tier contracting that a DBE/MBE goal can be achieved;
 - b. The prime contractor must request of the Administration, in writing, prior to the awarding of a contract, that approval be granted for each third tier contract arrangement. The request must contain the specifics as to why a third tier contracting arrangement is being requested to meet the DBE/MBE goal.

An Administration approving a third tier contract should do so in writing, setting forth the parameters of the third tier contract. All records of third tier contracts will be maintained by the Administration granting approval.

Third tier contracting is to be considered the exception and not the rule. If the third tier results from a DBE/MBE subcontracting to a non-DBE/MBE third tier contractor, this participation shall not be counted as DBE/MBE participation towards goal attainment.

MBE-4.02 Non-Compliance

- A. If it is determined that a contractor is not in compliance, the Administration's Representative may initiate an investigation. The Administration's Representative will notify the contractor of the results of the investigation as soon as practicable. The contractor and the Administration's Representative may meet informally to remedy any problems of compliance.

In the event conciliation fails, the Administration's Representative will inform the Administrator that the contractor is in non-compliance. The Administrator may

issue a "Show Cause Notice" which will delineate the deficiencies noted in the findings, establish a compliance conference date, outline the administrative actions to be taken, and provide a forum for the contractor to show that he is in compliance. A copy of the "Show Cause Notice" will be sent to the Administration's Contract Compliance Officer.

A finding of suspected certification or DBE/MBE fraud will not be shared with the contractor, or with the DBE/MBE. The available information shall be given to the MDOT Office of MBE or the MDOT Office of General Counsel.

MBE-4.03 Contract Compliance – Trucking

- A. A trucking firm, including an owner/operator trucker who wishes to participate as a DBE/MBE on any project of the Maryland Department of Transportation (MDOT), must be certified as a DBE/MBE by MDOT. Truckers, as with other subcontractors, may receive participation credit for the use of their vehicles in fulfilling contract specifications.
1. A DBE/MBE trucking company must own and have in operation at least one fully licensed, insured and operational truck to be used on a contract.
 2. A DBE/MBE trucking company must perform a commercially useful function (that is, responsible for the execution of a distinct element of work of a contract and carrying out its responsibilities by performing, managing and supervising the work involved). The DBE/MBE trucker, in the light of industry practice and other relevant considerations, must have a necessary and useful role in a transaction for which there is a market outside of the context of the DBE/MBE Program. The firm's role cannot be a superfluous step added in an attempt to obtain credit goals.
 3. The DBE/MBE must be responsible for the management, control and supervision of the entire trucking operation for which it is under contract on a project, without any contrived arrangement to meet DBE/MBE goals. Control includes the DBE/MBE trucker being responsible for scheduling, dispatching, paying employees, maintaining the trucks and keeping complete and accurate business records.
 4. The DBE/MBE receives credit for the total value of transportation services it provides using trucks it owns, insures and operates using drivers it employs.
 5. The DBE/MBE may lease trucks from another DBE/MBE firm, including owner/operators who are DBE/MBEs. Credit shall be given for total value of the transportation services the DBE/MBE provides as the subcontractor on a project.

6. The DBE/MBE may lease trucks from a non-DBE/MBE firm. When this is done, the DBE/MBE may receive credit only for the fee it receives as a result of the lease arrangement. The DBE/MBE does not receive credit for the total value of the transportation services provided since the services are not all provided by a DBE/MBE.

B. OWNER/OPERATOR

1. The DBE/MBE trucker who has ownership of one truck is an owner/operator. An owner/operator must be able to perform the contracted work items with the vehicle titled to the owner/operator.
2. The DBE/MBE trucker must have a written agreement with the prime contractor prior to performing any services on the project.
 - a. The written agreement shall indicate hours and/or tonnage price per load, mileage, cost of waiting time, if any, and the time of notification prior to reporting to work.
 - b. The written agreement should reflect the trucker's proposed goal as indicated on the prime contractor's approved Affirmative Action Plan.
 - c. The written agreement must be available upon the request of an Administration's Representative.

C. REGULAR DEALER

1. A DBE/MBE trucker is also a regular dealer if he or she owns and operates a warehouse or storage facility from where supplies are distributed.
2. The DBE/MBE Trucker/Regular Dealer must be recognized by the public and construction industry as a regular dealer. The DBE/MBE must also own distribution equipment to deliver bulk items too large to stockpile or store.
3. Sixty percent (60%) of the cost of supplies may be included for DBE/MBE credit (the cost should include the delivery charges) for a material hauler who is a DBE/MBE trucker who is also a regular dealer and certified as such by MDOT.
4. One hundred percent (100%) of the cost of materials is given for DBE/MBE credit when a DBE/MBE trucker is the manufacturer and operator of a material plant. A manufacturer must produce its product from raw materials. The DBE/MBE trucker must be certified as a manufacturer by MDOT.

D. LEASE/RENTAL OF VEHICLES

1. The DBE/MBE trucker may rent or lease trucks from an equipment rental firm to increase the number of trucks within the DBE/MBE firm. In this case, when the DBE/MBE trucker is responsible for the hiring and supervision of the drivers and maintenance and insurance of the trucks, these trucks are considered to be operated and controlled by the DBE/MBE trucker, therefore these trucks are counted for participation the same way as trucks owned by the DBE/MBE.
2. The DBE/MBE trucker must have a rental/lease agreement indicating the leaseholder's name, a description of the truck, including its identification number, the duration of the lease and the cost of the lease. This document shall be available for review by an Administration's Representative.
3. Any lease must indicate that the DBE/MBE has exclusive use of and control over the truck(s) under lease. The leased truck(s) may work for others during the term of the lease with the consent of the DBE/MBE as long as the DBE/MBE has absolute priority for the use of the leased truck(s). All leased trucks must display the name and identification number of the DBE/MBE firm indicating a leased truck i.e., "leased by.." A lease or written agreement includes written purchase orders.

E. MARYLAND AVIATION ADMINISTRATION REPORTING

A DBE/MBE trucker who is providing three or more trucks on a project shall submit a weekly report, "The Weekly Report of MBE Trucking Activities" to the prime contractor. The prime contractor shall submit this report to the Project Engineer as a part of the weekly payroll.

MBE-4.04 Liquidated Damages

This contract requires the Contractor to make good faith efforts to comply with the Minority Business Enterprise ("MBE") Program and contract provisions. The State and the Contractor acknowledge and agree that the State will incur damages, including but not limited to loss of goodwill, detrimental impact on economic development, and diversion of internal staff resources, if the Contractor does not make good faith efforts to comply with the requirements of the MBE Program and MBE contract provisions. The parties further acknowledge and agree that the damages the State might reasonably be anticipated to accrue as a result of such lack of compliance are difficult to ascertain with precision.

Therefore, upon a determination by the State that the Contractor failed to make good faith efforts to comply with one or more of the specified MBE Program requirements or contract provisions, the Contractor agrees to pay liquidated damages to the State at the rates set forth below. The Contractor expressly agrees that the State may withhold payment on any invoices as a set-off against liquidated damages owed. The Contractor further agrees that for each

specified violation, the agreed upon liquidated damages are reasonably proximate to the loss the State is anticipated to incur as a result of such violation.

- A. Failure to submit each monthly payment report in full compliance with COMAR 21.11.03.13B (3): \$23.00 per day until the monthly report is submitted as required.
- B. Failure to include in its agreements with MBE subcontractors a provision requiring submission of payment reports in full compliance with COMAR 21.11.03.13B (4): \$82.00 per MBE subcontractor.
- C. Failure to comply with COMAR 21.11.03.12 in terminating, canceling, or changing the scope of work/value of a contract with an MBE subcontractor and/or amendment of the MBE participation schedule: the difference between the dollar value of the MBE participation commitment on the MBE participation schedule for that specific MBE firm and the dollar value of the work performed by that MBE firm for the contract.
- D. Failure to meet the Contractor's total MBE participation goal and subgoal commitments: the difference between the dollar value of the total MBE participation commitment on the MBE participation schedule and the MBE participation actually achieved.

Notwithstanding the use of liquidated damages, the State reserves the right to terminate the contract and exercise all other rights and remedies provided in the contract or by law.

SECTION 5 LARGE COST SUPPLY ITEMS

MBE-5.01 Large Cost Supply Item

- A. For a prime contractor to receive full credit for a major or large cost item being furnished by a DBE/MBE subcontractor as a "furnish and install" item of work, the DBE/MBE firm must:
1. Initiate and negotiate the purchase of large supply items;
 2. Be invoiced directly for the cost;
 3. Assume complete responsibility and liability for the item; and
 4. Provide accounting records detailing how the large cost supply items are handled in the firm as supplies of the firm.
- B. The Department's DBE/MBE Contract Compliance Monitoring Procedures provide the necessary guidance on determining DBE/MBE credit on large supply items. There are several compliance issues which need to be addressed prior to a prime contractor receiving full credit for a DBE/MBE large cost supply item. These issues include:
1. Who was responsible for setting the dollar amount allotted for supplies on the forms detailing subcontracted work?
 2. How was the cost of supplies derived? Who negotiated the price?
 3. Who is responsible for taking delivery of the materials?
 4. Who issues the check to pay for the materials?
 5. Who assumes contractual and legal responsibility for the materials?
 6. Are the materials properly accounted for in the financial records of the subcontractor and consequently, not in the records of the prime contractor?
- C. The Compliance Officer must provide written notice to the contractors prior to the "notice to proceed" indicating that pertinent financial records shall be subject to audit by the State to document the actual purchase of large cost supply items.
- D. It should be made clear to the prime contractor at the beginning of a contract that obtaining participation through the counting of large cost supply items must comply

with the Department's regulations. This also extends to the amount of credit given for the supply items on each contract.

- E. The burden rests on each administration to assess each individual contract prior to the approval of the DBE/MBE package and to monitor the contract closely for compliance. This continuous work is necessary to make sure this program brings real benefits to the minority business community.
- F. Structural Steel: Special considerations regarding structural steel as a large cost supply item are included in an attachment to these regulations. (See **MBE-5.02**).

MBE-5.02 Structural Steel

- A. Definition: The term structural steel refers to the steel elements of the structural steel frame essential to the support of the design loads for buildings and bridges, as well as the steel elements in tunnel linings.
- B. Structural steel is eliminated as a subcontracting item for setting DBE/MBE goals on contracts, as an item of supply. Additionally, as an item of supply, structural steel will not be used to obtain or count disadvantaged/minority business participation under the Disadvantaged/Minority Business Enterprise Program. The installation or erection of structural steel, however, should remain a subcontractible item and as an item available for DBE/MBE participation. The exception to this policy would be the use of a certified DBE/MBE structural steel manufacturer or certified DBE/MBE structural steel fabricator.
- C. Beyond this policy on structural steel, it is vitally important for each Administration to apply the provisions of the DBE/MBE Program for furnishing and installing large cost supply items, including the requirement that a DBE/MBE perform a commercially useful function on any contract. The DBE/MBE must have a necessary and useful role in the business transaction, visible outside of the context of the DBE/MBE Program. The role of the DBE/MBE cannot be a superfluous step established to obtain credit under the DBE/MBE Program.

SECTION 6 GOOD FAITH EFFORTS

MBE-6.01 Good Faith Efforts

If for any reason, a bidder or offeror is unable to achieve the contract goal for certified DBE/MBE participation, the bidder or offeror may request in writing a waiver to the goal. The bidder or offeror must justify, with sufficient written documentation, the bidder or offeror's good faith efforts to achieve the contract goal. These provisions are in effect during the life of the contract.

The following is a listing of efforts that can be made and will be considered a part of bidder's good faith efforts to meet the contract goal.

- A. Coordinating any pre-bid meetings at which DBE/MBEs could be informed of contracting and subcontracting opportunities.
- B. Advertising in general circulation, trade association, and minority focused media concerning the subcontract opportunities.
- C. Providing written notice to all certified DBE/MBEs who are certified in work areas and who have capabilities of the contract for which their participation is solicited. This notice should be provided in sufficient time to allow the DBE/MBEs to respond to the written solicitation in accordance with COMAR 21.11.03.09B(2)(b)(ii) providing a minimum of 10 days to respond.
- D. Following up initial solicitations of interest by contacting DBE/MBEs to determine if the DBE/MBEs are interested. Detailing the efforts with the names, addresses, dates, and telephone numbers of the certified DBE/MBEs contacted along with a description of the information provided to certified DBE/MBEs regarding the plans, specifications and anticipated time schedule for portions of the work to be performed.
- E. Selecting portions of the work to be performed by DBE/MBEs in order to increase the likelihood of the DBE/MBE goals being achieved.
- F. Providing interested DBE/MBEs with adequate information about the plan specifications and requirements of the contract.
- G. Negotiating in good faith with interested DBE/MBEs.
- H. A bidder or offeror shall not reject a DBE/MBE as unqualified without sound reasons based on a thorough investigation of DBE/MBE capabilities. For each certified DBE/MBE that is rejected as unqualified or that placed a subcontract quotation or offer that the bidder or offeror considers not to be acceptable, the

bidder or offeror shall provide a written detailed statement listing the reasons for this conclusion.

- I. Making an effort to assist interested DBE/MBEs in obtaining bonding, lines of credit, or insurance as required by the contractor.
- J. Effectively using the services of available minority/women contractors' groups, local, state and Federal minority/women business assistance offices and other organizations to provide assistance in the recruitment and placement of DBE/MBE subcontracts.
- K. As a minimum, if for any reason, the contractor is unable to award subcontracts or procure supplies and services with a value that is equal to the minimum goal established in the solicitation, the contractor will document its "Good Faith Efforts" in writing, with justification to include, but not limited to, the following:
 - 1. A statement detailing the efforts made to contact and negotiate with certified businesses including:
 - a. The names, addresses, dates, and telephone numbers of the certified businesses who were contacted; and
 - b. A copy of the information provided to the certified DBE/MBEs regarding the plans, specifications and anticipated time schedule for portions of the work to be performed.
 - 2. A detailed statement listing the items or selected portions of work proposed to be performed by certified businesses in order to increase the likelihood of achieving the stated goal.
 - 3. A statement detailing the reasons for a contractor's conclusion that a certified DBE/MBE subcontractor is not qualified to perform.
 - 4. A list of certified businesses contacted but found to be unavailable. This list should be accompanied by Minority Contractor Unavailability Certificates (Form D-EEO-005) signed by the minority contractor or a statement from the apparent low bidder that the certified businesses refused to sign the Minority Contractor Unavailability Certification.
- L. In making a determination of Good Faith Efforts the agency head or designee may consider engineering estimates, catalogue prices, general market availability and availability of certified DBE/MBEs in the area in which the work is to be performed, other bids or offers and subcontract bids or offers substantiating significant variances between certified DBE/MBE and non-DBE/MBE costs of participation, and their impact on the overall cost of the contract to the State and any other

relevant factors. The contractor will not receive a waiver in instances where they can (or want to) perform work with their own forces.

- M. If and when the successful bidder has demonstrated his complete compliance with these procedures and this is thoroughly documented, the Administration Representative will refer the request to the Administrator.
- N. Based on the Administration Representative's evaluation, the Administrator will determine the adequacy of the apparent low bidder's MBE Participation Program. The Administrator will determine if it is in conformance with the MDOT MBE Program.
- O. Unless an objection is filed by the apparent low bidder in writing within fifteen (15) days of the Administrator's determination, the Administrator's determination is final. In the event an objection is filed, the Administrator will send the apparent low bidder a Notice of Opportunity to meet with the Administrator, indicating the date, time, and place. At that time, the Administrator may request additional information from the apparent low bidder.
- P. A copy of the determination will be sent to the apparent low bidder and other interested parties. The apparent low bidder and other interested parties may appeal the Administrator's decision to the Secretary of Transportation.

PART IV

Provisions for Federal-Aid Contracts

SECTION 1 FAA REQUIREMENTS

FAA-1.01 Notice of Requirement for Affirmative Action to Ensure Equal Employment Opportunity

- A. The following shall be a part of all solicitations for bids on all federally assisted construction contracts in excess of Ten Thousand Dollars (\$10,000.00) in accordance with **Executive Order 11246**, as amended, to ensure equal employment opportunity.
- B. The Offeror's or Bidder's attention is called to the "Equal Opportunity Clause" and the "Standard Federal Equal Employment Opportunity Construction Contract Specifications" set forth herein.
- C. The goals and timetables for minority and female participation, expressed in percentage terms for the contractor's aggregate workforce in each trade on all construction work in the covered area, are as follows:

Timetables

Goals for Minority Participation for each trade: **[Sponsor must insert Established Goals]**

Goals for Female Participation in each trade: 6.9%

- 1. These goals are applicable to all of the contractor's construction work (whether or not it is Federal or federally-assisted) performed in the covered area. If the contractor performs construction work in a geographical area located outside of the covered area, it shall apply the goals established for such geographical area where the work is actually performed. With regard to this second area, the contractor also is subject to the goals for both its federally involved and non-federally involved construction.
- 2. The Contractor's compliance with the Executive Order and the regulations in **41 CFR Part 60-4** shall be based on its implementation of the Equal Opportunity Clause, specific affirmative action obligations required by the specifications set forth in **41 CFR 60-4.3(a)**, and its efforts to meet the goals. The hours of minority and female employment and training must be substantially uniform throughout the length of the contract, and in each trade, and the contractor shall make a good faith effort to employ minorities and women evenly on each of its projects. The transfer of minority or female employees or trainees from Contractor to Contractor or from project to

project for the sole purpose of meeting the Contractor's goals shall be a violation of the contract, the Executive Order and the regulations in 41 CFR Part 60-4. Compliance with the goals will be measured against the total work hours performed.

- D. The Contractor shall provide written notification to the Director of the Office of Federal Contract Compliance Programs (OFCCP) within 10 working days of award of any construction subcontract in excess of \$10,000 at any tier for construction work under the contract resulting from this solicitation. The notification shall list the name, address, and telephone number of the subcontractor; employer identification number of the subcontractor; estimated dollar amount of the subcontract; estimated starting and completion dates of the subcontract; and the geographical area in which the subcontract is to be performed..
- E. As used in this notice and in the Contract resulting from this solicitation, the "covered area" is Baltimore, Maryland SMSA Counties including, Anne Arundel County and/or Baltimore County.
- F. For the Contractor's information, the Department of Labor has eliminated all imposed EEO Plans and the Philadelphia Plan as a means of complying with **Executive Order 11246**, as amended. Hometown Plans can still be used; however, signatories are required to submit goals and timetables for the utilization of women to the Director, Office of Federal Contract Compliance Program, Department of Labor, Washington, D.C.

FAA-1.02 Certification of Nonsegregated Facilities

All bidders will be required to submit a Certification of Nonsegregated employee facilities including an agreement to get a similar certification from proposed subcontractors. These certifications will be required prior to award of contract. The wording for these certifications is stated hereafter under **FAA-1.03**.

FAA-1.03 Contractor's Certification of Nonsegregated Facilities

- A. The Contractor is directed to Standard Provisions, Part V, Section 4, Sample Forms for Federal-Aid Contracts, **FAA-4.01**, for a sample of executable form for Certification of Nonsegregated Facilities.

FAA-1.04 Access to Records and Reports

- A. The Contractor must maintain an acceptable cost accounting system. The Contractor agrees to provide the MAA, the Federal Aviation Administration, and the Comptroller General of the United States or any of their duly authorized representatives, access to any books, documents, papers, and records of the contractor which are directly pertinent to the specific contract for the purpose of

making audit, examination, excerpts and transcriptions. The Contractor agrees to maintain all books, records and reports required under this contract for a period of not less than three years after final payment is made and all pending matters are closed.

FAA-1.05 Equal Employment Opportunity Clause

A. During the performance of this contract, the Contractor agrees as follows:

1. The contractor will not discriminate against any employee or applicant for employment because of race, color, religion, sex, or national origin. The contractor will take affirmative action to ensure that applicants are employed, and that employees are treated during employment without regard to their race, color, religion, sex, sexual orientation, gender identify or national origin. Such action shall include, but not be limited to the following: employment, upgrading, demotion, or transfer; recruitment or recruitment advertising; layoff or termination; rates of pay or other forms of compensation; and selection for training, including apprenticeship. The contractor agrees to post in conspicuous places, available to employees and applicants for employment, notices to be provided setting forth the provisions of this nondiscrimination clause.
2. The contractor will, in all solicitations or advertisements for employees placed by or on behalf of the contractor, state that all qualified applicants will receive considerations for employment without regard to race, color, religion, sex, or national origin.
3. The contractor will send to each labor union or representative of workers with which he has a collective bargaining agreement or other contract or understanding, a notice to be provided advising the said labor union or workers' representatives of the contractor's commitments under this section, and shall post copies of the notice in conspicuous places available to employees and applicants for employment.
4. The contractor will comply with all provisions of **Executive Order 11246** of September 24, 1965, as amended, and of the rules, regulations, and relevant orders of the Secretary of Labor.
5. The contractor will furnish all information and reports required by **Executive Order 11246** of September 24, 1965, as amended, and by rules, regulations, and orders of the Secretary of Labor, or pursuant thereto, and will permit access to his books, records, and accounts by the administering agency and the Secretary of Labor for purposes of investigation to ascertain compliance with such rules, regulations, and orders.

6. In the event of the contractor's noncompliance with the nondiscrimination clauses of this contract or with any of the said rules, regulations, or orders, this contract may be canceled, terminated, or suspended in whole or in part and the contractor may be declared ineligible for further Government contracts or federally assisted construction contracts in accordance with procedures authorized in **Executive Order 11246** of September 24, 1965, as amended, and such other sanctions may be imposed and remedies invoked as provided in **Executive Order 11246** of September 24, 1965, as amended, or by rule, regulation, or order of the Secretary of Labor, or as otherwise provided by law.
 7. The contractor will include the portion of the sentence immediately preceding paragraph (1) and the provisions of paragraphs (1) through (7) in every subcontract or purchase order unless exempted by rules, regulations, or orders of the Secretary of Labor issued pursuant to **section 204 of Executive Order 11246** of September 24, 1965, as amended, so that such provisions will be binding upon each subcontractor or vendor. The contractor will take such action with respect to any subcontract or purchase order as the administering agency may direct as a means of enforcing such provisions, including sanctions for noncompliance: *Provided, however,* That in the event a contractor becomes involved in, or is threatened with, litigation with a subcontractor or vendor as a result of such direction by the administering agency the contractor may request the United States to enter into such litigation to protect the interests of the United States.
- B. Contractors and subcontractors may satisfy the requirements of Paragraph A.2. above, by complying with any of the following:
1. Stating in the Invitations for Bids that all qualified applicants will receive consideration for employment without regard to race, color, religion, sex, or national origin, or
 2. Including appropriate insignia in display or other advertising as prescribed by the Department of Labor, or
 3. Using a single advertisement grouped with other advertisements under a caption which clearly states that all employers in the group assure all qualified applicants will have equal consideration for employment without regard to race, color, religion, sex, or national origin, or
 4. Using the phrase "An Equal Opportunity Employer" in a single advertisement in clearly distinguishable type.

FAA-1.06 Standard Federal Equal Employment Opportunity Construction Contract Specifications

- A. The following Specifications is hereby made a part of all federally assisted construction contracts or subcontracts over Ten Thousand Dollars (\$10,000.00) in accordance with **Executive Order 11246**, as amended.
- B. As used in these Specifications:
1. “Covered area” means the geographical area described in the solicitation from which this Contract resulted;
 2. “Director” means Director, Office of Federal Contract Compliance Programs (OFCCP), U.S. Department of Labor, or any person to whom the Director delegates authority;
 3. “Employer identification number” means the Federal Social Security Number used on the Employers Quarterly Federal Tax Return, U.S. Treasury Department Form 941;
 4. “Minority” includes:
 - a. Black (all persons having origins in any of the Black African racial groups not of Hispanic origin);
 - b. Hispanic (all persons of Mexican, Puerto Rican, Cuban, Central or South American, or other Spanish culture or origin regardless of race);
 - c. Asian and Pacific Islander (all persons having origins in any of the original peoples of the Far East, Southeast, Asia, the Indian Subcontinent, or the Pacific Islands); and
 - d. American Indian or Alaskan Native (all persons having origins in any of the original peoples of North America and maintaining identifiable tribal affiliation through membership and participation or community identification).
- C. Whenever the Contractor, or any subcontractor at any tier, subcontracts a portion of the work involving any construction trade, it shall physically include in each subcontract in excess of Ten Thousand Dollars (\$10,000) the provisions of these specifications and the notice which contains the applicable goals for minority and female participation and which is set forth in the solicitation from which this Contract resulted.

- D. If the Contractor is participating (pursuant to **41 CFR 60-4.5**) in a Hometown Plan approved by the U.S. Department of Labor in the covered area either individually or through an association, its affirmative action obligations on all work in the Plan area (including goals and timetables) shall be in accordance with Plan for those trades which have unions participating in the Plan. Contractors must be able to demonstrate their participation and in compliance with the provisions of any such Hometown Plan. Each contractor or subcontractor participating in an approved Plan is individually required to comply with its obligations under the EEO clause and to make a good faith effort to achieve each goal under the Plan in each trade in which it has employees. The overall good faith performance by other contractors or subcontractors toward a goal in an approved Plan does not excuse any covered Contractor's or subcontractor's failure to take good faith efforts to achieve the Plan goals and timetables.
- E. The Contractor shall implement the specific affirmative action standards in Paragraphs H.1. through H.16. of these Specifications. The goals set forth in the solicitation from which this Contract resulted are expressed as percentages of the total hours of employment and training of minority and female utilization the Contractor should reasonably be able to achieve in each construction trade in which it has employees in the covered areas. Covered construction contractor's performing construction work in a geographical area where they do not have a Federal or federally assisted construction contract shall apply the minority and female goals established for the geographical area where the work is being performed. Goals are published periodically in the Federal Register in notice form, and such notices may be obtained from any OFCCP office or from Federal procurement contracting officers. The Contractor is expected to make substantially uniform progress in meeting its goals in each craft during the period specified.
- F. Neither the provisions of any collective bargaining agreement nor the failure by a union with whom the Contractor has a collective bargaining agreement to refer either minorities or women shall excuse the Contractor's obligations under these specifications, **Executive Order 11246**, or the regulations promulgated pursuant thereto.
- G. In order for the non-working training hours of apprentices and trainees to be counted in meeting the goals, such apprentices and trainees shall be employed by the contractor during the training period and the contractor shall have made a commitment to employ the apprentices and trainees at the completion of their training, subject to the availability of employment opportunities. Trainees shall be trained pursuant to training programs approved by the U.S. Department of Labor.
- H. The contractor shall take specific affirmative actions to ensure equal employment opportunity. The evaluation of the contractor's compliance with these specifications shall be based upon its effort to achieve maximum results from its

actions. The contractor shall document these efforts fully and shall implement affirmative action steps at least as extensive as the following:

1. Ensure and maintain in a working environment free of harassment, intimidation, and coercion at all sites, and in all facilities at which the Contractor's employees are assigned to work. The Contractor, where possible, will assign two or more women to each construction project. The Contractor shall specifically ensure that all foremen, superintendents, and other on-site supervisory personnel are aware of and carry out the Contractor's obligation to maintain such a working environment, with specific attention to minority or female individuals working at such sites or in such facilities.
2. Establish and maintain a current list of minority and female recruitment sources, provide written notification to minority and female recruitment sources and to community organizations when the Contractor or its unions have employment opportunities available, and maintain a record of the organizations' responses.
3. Maintain a current file of the names, addresses, and telephone numbers of each minority and female off-the-street applicant and minority or female referral from a union, a recruitment source, or community organization and of what action was taken with respect to each such individual. If such individual was sent to the union hiring hall for referral and was not referred back to the contractor by the union or, if referred, not employed by the Contractor, this shall be documented in the file with the reason therefore along with whatever additional actions the Contractor may have taken.
4. Provide immediate written notification to the Director when the union or unions with which the contractor has a collective bargaining agreement has not referred to the contractor a minority person or female sent by the contractor, or when the contractor has other information that the union referral process has impeded the contractor's efforts to meet its obligations.
5. Develop on-the-job training opportunities and/or participate in training programs for the areas which expressly include minorities and women, including upgrading programs and apprenticeship and trainee programs relevant to the Contractor's employment needs, especially those programs funded or approved by the Department of Labor. The Contractor shall provide notice of these programs to the sources complied under H.2. above.
6. Disseminate the Contractor's EEO policy by providing notice of the policy to unions and training programs and requesting their cooperation in assisting the Contractor in meeting its EEO obligations; by including in it any policy manual and collective bargaining agreement; by publicizing it in the company newspaper, annual report, etc.; by specific review of the policy

with all management personnel with all minority and female employees at least once a year; and by posting the company EEO policy on bulletin boards accessible to all employees at each location where construction work is performed.

7. Review, at least annually, the Company's EEO policy and affirmative action obligations under these Specifications with all employees having any responsibility for hiring, assignment, layoff, termination, or other employment decisions including specific review of these items with on-site supervisory personnel such as superintendents, general foremen, etc., prior to the initiation of construction work at any job site. A written record shall be made and maintained identifying the time and place of these meetings, persons attending, subject matter discussed, and disposition of the subject matter.
8. Disseminate the contractor's EEO policy externally by including it in any advertising in the news media, specifically including minority and female news media, and providing written notification to and discussing the contractor's EEO policy with other contractors and subcontractors with whom the contractor does or anticipates doing business.
9. Direct its recruitment efforts, both oral and written, to minority, female, and community organizations, to schools with minority and female students; and to minority and female recruitment and training organizations serving the Contractor's recruitment area and employment needs. Not later than one month prior to the date for the acceptance of applications for apprenticeship or other training by any recruitment source, the Contractor shall send written notification to organizations, such as the above, describing the openings, screening procedures, and tests to be used in selection process.
10. Encourage present minority and female employees to recruit other minority persons and women and, where reasonable, provide after school, summer, and vacation employment to minority and female youth both on site and in other areas of a contractor's workforce.
11. Validate all tests and other selection requirements where there is an obligation to do so under **41 CFR Part 60-3**.
12. Conduct, at least annually, an inventory and evaluation, at least of all minority and female personnel, for promotional opportunities and encourage these employees to seek or to prepare for, through appropriate training, etc., such opportunities.
13. Ensure that seniority practices, job classifications, work assignments, and other personnel practices do not have a discriminatory effect by continually monitoring all personnel and employment related activities to ensure that

the EEO policy and the Contractor's obligations under these specifications are being carried out.

14. Ensure that all facilities and company activities are non-segregated except that separate or single-user toilet and necessary changing facilities shall be provided to assure privacy between the sexes.
 15. Document and maintain a record of all solicitations of offers for subcontracts from minority and female construction contractors and suppliers, including circulation of solicitations to minority and female contractor associations and other business associations.
 16. Conduct a review, at least annually, of all supervisors' adherence to and performance under the Contractor's EEO policies and affirmative action obligations.
- I. Contractors are encouraged to participate in voluntary associations which assist in fulfilling one or more of their affirmative action obligations (H.1 through H.16). The efforts of a contractor association, joint contractor-union, contractor-community, or other similar groups of which the Contractor is a member and participant, may be asserted as fulfilling any one or more of its obligations under H.1 through H.16 of these specifications provided that the Contractor actively participates in the group, makes every effort to assure that the group has a positive impact on the employment of minorities and women in the industry, ensures that the concrete benefits of the program are reflected in the Contractor's minority and female workforce participation, makes good faith effort to meet its individual goals and timetables, and can provide access to documentation which demonstrates the effectiveness of actions taken on behalf of the Contractor. The obligation to comply, however, is the Contractor's and failure of such a group to fulfill an obligation shall not be a defense for the Contractor's noncompliance.
- J. A single goal for minorities and a separate single goal for women have been established. The contractor, however, is required to provide equal employment opportunity and to take affirmative action for all minority groups, both male and female, and all women, both minority and non-minority. Consequently, if the particular group is employed in a substantially disparate manner (for example, even though the contractor has achieved its goals for women generally,) the contractor may be in violation of the Executive Order if a specific minority group of women is underutilized.
- K. The Contractor shall not use the goals and timetables or affirmative action standards to discriminate against any person because of race, color, religion, sex, or national origin.

- L. The Contractor shall not enter into any subcontract with any person or firm debarred from Government contracts pursuant to **Executive Order 11246**, as amended.
- M. The Contractor shall carry out such sanctions and penalties for violations of these specifications and of the Equal Opportunity Clause, including suspension, termination, and cancellation of existing subcontracts as may be imposed or ordered pursuant to **Executive Order 11246**, as amended, and in its implementing regulations, by the OFCCP. Any contractor who fails to carry out such sanctions and penalties shall be in violation of these specifications and **Executive Order 11246**, as amended.
- N. The Contractor, in fulfilling its obligations under these specifications, shall implement specific affirmative action steps, at least as extensive as those standards prescribed in paragraph H of these Specifications so as to achieve maximum results from its efforts to ensure equal employment opportunity. If the Contractor fails to comply with the requirements of the executive order, the implementing regulations, or these specifications, the Director shall proceed in accordance with **41 CFR 60-4.8**.
- O. The Contractor shall designate a responsible official to monitor all employment related activity to ensure that the company EEO policy is being carried out, to submit reports relating to the provisions hereof as may be required by the Government, and to keep records. Records shall at least include for each employee, the name, address, telephone number, construction trade, union affiliation if any, employee identification number when assigned, social security number, race, sex, status (e.g., mechanic, apprentice, trainee, helper, or laborer), dates of changes in status, hours worked per week in the indicated trade, rate of pay, and locations at which the work was performed. Records shall be maintained in an easily understandable and retrievable form; however, to the degree that existing records satisfy this requirement, contractors shall not be required to maintain separate records.
- P. Nothing herein provided shall be construed as a limitation upon the application of other laws which establish different standards of compliance or upon the application of requirements for the hiring of local or other area residents (e.g., those under the **Public Works Employment Act of 1977** and the Community Development Block Grant Program).

FAA-1.07 Title VI Clauses for Compliance with Nondiscrimination Requirements

- A. During the performance of this Contract, the Contractor, for itself, its assigns and successors in interest (hereinafter referred to as the Contractor) agrees as follows:

1. **Compliance with Regulations:** The contractor (hereinafter includes consultants) will comply with the Title VI List of Pertinent Nondiscrimination Acts And Authorities, as they may be amended from time to time, which are herein incorporated by reference and made a part of this contract.
2. **Non-discrimination:** The contractor, with regard to the work performed by it during the contract, will not discriminate on the grounds of race, color, or national origin in the selection and retention of subcontractors, including procurements of materials and leases of equipment. The contractor will not participate directly or indirectly in the discrimination prohibited by the Nondiscrimination Acts and Authorities, including employment practices when the contract covers any activity, project, or program set forth in Appendix B of 49 CFR part 21.
3. **Solicitations for Subcontracts, Including Procurements of Materials and Equipment:** In all solicitations, either by competitive bidding, or negotiation made by the contractor for work to be performed under a subcontract, including procurements of materials, or leases of equipment, each potential subcontractor or supplier will be notified by the contractor of the contractor's obligations under this contract and the Nondiscrimination Acts And Authorities on the grounds of race, color, or national origin.
4. **Information and Reports:** The contractor will provide all information and reports required by the Acts, the Regulations, and directives issued pursuant thereto and will permit access to its books, records, accounts, other sources of information, and its facilities as may be determined by the sponsor or the Federal Aviation Administration to be pertinent to ascertain compliance with such Nondiscrimination Acts And Authorities and instructions. Where any information required of a contractor is in the exclusive possession of another who fails or refuses to furnish the information, the contractor will so certify to the sponsor or the Federal Aviation Administration, as appropriate, and will set forth what efforts it has made to obtain the information.
5. **Sanctions for Noncompliance:** In the event of a contractor's noncompliance with the Non-discrimination provisions of this contract, the sponsor will impose such contract sanctions as it or the Federal Aviation Administration may determine to be appropriate, including, but not limited to:
 - a. Withholding payments to the contractor under the contract until the contractor complies; and/or
 - b. Cancelling, terminating, or suspending a contract, in whole or in part.

6. **Incorporation of Provisions:** The contractor will include the provisions of paragraphs one through six in every subcontract, including procurements of materials and leases of equipment, unless exempt by the Acts, the Regulations and directives issued pursuant thereto. The contractor will take action with respect to any subcontract or procurement as the sponsor or the Federal Aviation Administration may direct as a means of enforcing such provisions including sanctions for noncompliance. Provided, that if the contractor becomes involved in, or is threatened with litigation by a subcontractor, or supplier because of such direction, the contractor may request the sponsor to enter into any litigation to protect the interests of the sponsor. In addition, the contractor may request the United States to enter into the litigation to protect the interests of the United States.
7. **Breach of Contract:** Any violation or breach of terms of this contract on the part of the contractor or its subcontractors may result in the suspension or termination of this contract or such other action that may be necessary to enforce the rights of the parties of this agreement.

Owner will provide Contractor written notice that describes the nature of the breach and corrective actions the Contractor must undertake in order to avoid termination of the contract. Owner reserves the right to withhold payments to Contractor until such time the Contractor corrects the breach or the Owner elects to terminate the contract. The Owner's notice will identify a specific date by which the Contractor must correct the breach. Owner may proceed with termination of the contract if the Contractor fails to correct the breach by deadline indicated in the Owner's notice.

The duties and obligations imposed by the Contract Documents and the rights and remedies available thereunder are in addition to, and not a limitation of, any duties, obligations, rights and remedies otherwise imposed or available by law

FAA-1.08 Standard Requirements for AIP Contracts

- A. AIP Project. The work in this Contract is included in AIP Project Number (as indicated in the Technical Provisions and Contract Drawings) which is being undertaken and accomplished by the Maryland Aviation Administration in accordance with the terms and conditions of a grant agreement between the Maryland Aviation Administration, hereinafter referred to as the Sponsor, and the United States, under the **Airport and Airway Safety and Capacity Expansion Act of 1987 (AASCEA) (P.L. 100-223)**, **Aviation Safety and Capacity Expansion Act of 1990 and part 152 of the Federal Aviation Regulations (FAR) (14 CFR Part 152)**, or any successor regulation, pursuant to which the United States has agreed to pay a certain percentage of that Act. The United States is not a party to this Contract and no reference in this Contract to the FAA

or any representative thereof, or in any rights granted to the FAA or any representative thereof, or the United States, by the Contract, makes the United States a party to this Contract.

- B. Consent to Assignment. The Contractor shall obtain the prior written consent of the Sponsor to any proposed assignment of any interest in or part of this Contract.
- C. Veteran's Preference. In the employment of labor (excluding executive, administrative, and supervisory positions), the contractor and all sub-tier contractors must give preference to covered veterans as defined within Title 49 United States Code Section 47112. Covered veterans include Vietnam-era veterans, Persian Gulf veterans, Afghanistan-Iraq war veterans, disabled veterans, and small business concerns (as defined by 15 U.S.C. 632) owned and controlled by disabled veterans. This preference only applies when there are covered veterans readily available and qualified to perform the work to which the employment relates.
- D. FAA Inspection and Review. The Contractor shall allow any authorized representative of the FAA to inspect and review any work or materials used in the performance of this Contract.
- E. Inspection Records. The Contractor shall maintain an acceptable cost accounting system. The Sponsor, the FAA, and the Comptroller General of the United States shall have access to any books, documents, papers, and records of the Contractor which are directly pertinent to the specific contract for the purpose of making audit, examination, excerpts, and transcriptions. The Contractor shall maintain all required records for three (3) years after the Sponsor makes final payment and all other pending matters are closed.
- F. Rights to Inventions. Contracts or agreements that include the performance of experimental, developmental, or research work must provide for the rights of the Federal Government and the Owner in any resulting invention as established by 37 CFR part 401, Rights to Inventions Made by Non-profit Organizations and Small Business Firms under Government Grants, Contracts, and Cooperative Agreements. This contract incorporates by reference the patent and inventions rights as specified within in the 37 CFR §401.14. Contractor must include this requirement in all sub-tier contracts involving experimental, developmental or research work.
- G. Disadvantaged Business Enterprise (DBE). It is the policy of the Department of Transportation that DBEs shall have the maximum opportunity to participate in the performance of this Contract. The Contractor agrees to ensure that DBEs have the maximum opportunity to participate in the performance of subcontracts. In this regard, the Contractor shall take all necessary and reasonable steps in accordance with **49 CFR Part 23** to ensure that DBEs have the maximum opportunity to compete for and perform subcontracts. Contractors shall not discriminate on the

basis of race, color, national origin, or sex in the award and performance of this Contract.

- H. Seismic Safety. The contractor agrees to ensure that all work performed under this contract, including work performed by subcontractors, conforms to a building code standard that provides a level of seismic safety substantially equivalent to standards established by the National Earthquake Hazards Reduction Program (NEHRP). Local building codes that model their code after the current version of the International Building Code (IBC) meet the NEHRP equivalency level for seismic safety

FAA-1.09 Clean Air and Water Pollution Control Requirements

Contractors and subcontractors for any contract or subcontract exceeding One Hundred Fifty Thousand Dollars (\$150,000.00) agree:

1. That any facility to be used in the performance of the Contract or to benefit from the Contract is not listed on the Environmental Protection Agency (EPA) List of Violating Facilities.
2. To comply with all the requirements of **Section 114** of the Clean Air Act and **Section 308** of the Federal Water Pollution Control Act and all regulations issued thereunder.
3. That as a condition for award of a contract they will notify the awarding official of the receipt of any communication from the EPA indicating that a facility to be utilized for performance of or benefit from the Contract is under consideration to be listed on the EPA List of Violating Facilities.
4. To comply with all applicable standards, orders, and regulations issued pursuant to the Clean Air Act (42 U.S.C. § 740-7671q) and the Federal Water Pollution Control Act as amended (33 U.S.C. § 1251-1387). The Contractor agrees to report any violation to the Owner immediately upon discovery. The Owner assumes responsibility for notifying the Environmental Protection Agency (EPA) and the Federal Aviation Administration
5. To include or cause to be included in any contract or subcontract which exceeds One Hundred Fifty Thousand Dollars (\$150,000.00) the aforementioned criteria and requirements.

FAA-1.10 Bonding/Insurance

The following clauses shall apply to all federally assisted construction contracts, for bids and/or contracts in excess of One Hundred Thousand Dollars (\$100,000.00):

1. The Contractor agrees to furnish a performance bond for one hundred percent (100%) of the Contract price. This bond is one that is executed in connection with a contract to secure fulfillment of all contractor's obligations under such contract.
2. The Contractor agrees to furnish a payment bond for one hundred percent (100%) of the Contract price. This bond is one that is executed in connection with a contract to assure payment as required by law of all persons supplying labor and materials in the execution of the work provided for in the Contract.

FAA-1.11 DBE Requirements

- A. DBE requirements are applicable to each general aviation airport sponsor receiving grant funds in excess of Two Hundred Fifty Thousand Dollars (\$250,000); each non-hub airport sponsor (including commuters) receiving a grant in excess of Four Hundred Thousand Dollars (\$400,000); each large, medium, small hub airport sponsor receiving a grant in excess of Five Hundred Thousand Dollars (\$500,000).
- B. When a contract to be awarded falls into the above category, the bid is subject to the following DBE requirements:
 1. The successful bidder shall make a good faith effort to use DBE subcontractors and to replace a DBE subcontractor that is unable to perform successfully with another DBE subcontractor. There shall be no substitution of any subcontractors without the prior approval of the sponsor in order to ensure that the substitute firm is an eligible DBE.
 2. The bidder shall make good faith efforts, as defined in **Appendix A of 49 CFR Part 23**, Regulations of the Office of the Secretary of Transportation, to subcontract (percentage as specified in the Technical Provisions) of the dollar value of the Prime Contract to small business concerns owned and controlled by socially and economically disadvantaged individuals (DBE). In the event that the bidder for this solicitation qualifies as a DBE, the Contract goal shall be deemed to have been met. Individuals who are reputedly presumed to be socially and economically disadvantaged include Women, Blacks, Hispanics, Native Americans, Asian – Pacific Americans, and Asian-Indian Americans. The apparent successful competitor will be required to submit information concerning the DBEs that will participate in this Contract. The information will include the name and address of each DBE, a value of the Contract. If the bidder fails to achieve the stated Contract goal, it will be required to provide documentation demonstrating that it made good faith efforts in attempting to do so. A bid that fails to meet these requirements will be considered nonresponsive.

3. The successful bidder shall establish and maintain records and submit reports, as required, which will identify and assess the efforts made to achieve MBE subcontract goals and other DBE affirmative actions efforts.

FAA-1.12 Trade Restriction Certification

- A. By submission of an offer, the Offeror certifies that with respect to this solicitation and any resultant contract, the Offeror:
 1. is not owned or controlled by one or more citizens of a foreign country included in the list of countries that discriminate against U.S. firms as published by the Office of the United States Trade Representative (U.S.T.R.);
 2. has not knowingly entered into any contract or subcontract for this project with a person that is a citizen or national of a foreign country included on the list of countries that discriminate against U.S. firms as published by the U.S.T.R.; and
 3. has not entered into any subcontract for any product to be used on the Federal on the project that is produced in a foreign country included on the list of countries that discriminate against U.S. firms published by the U.S.T.R.
- B. This certification concerns a matter within the jurisdiction of an agency of the United States of America and the making of a false, fictitious, or fraudulent certification may render the maker subject to prosecution under Title 18, United States Code, Section 1001.
- C. The Offeror/Contractor must provide immediate written notice to the Owner if the Offeror/Contractor learns that its certification or that of a subcontractor was erroneous when submitted or has become erroneous by reason of changed circumstances. The Contractor must require subcontractors provide immediate written notice to the Contractor if at any time it learns that its certification was erroneous by reason of changed circumstances.
- D. Unless the restrictions of this clause are waived by the Secretary of Transportation in accordance with **49 CFR 30.17**, no contract shall be awarded to an Offeror or subcontractor:
 1. who is owned or controlled by one or more citizens or nationals of a foreign country included on the list of countries that discriminate against U.S. firms published by the U.S.T.R. or

2. whose subcontractors are owned or controlled by one or more citizens or nationals of a foreign country on such U.S.T.R. list or
 3. who incorporates in the public works project any product of a foreign country on such U.S.T.R. list;
- E. Nothing contained in the foregoing shall be construed to require establishment of a system of records in order to render, in good faith, the certification required by this provision. The knowledge and information of a contractor is not required to exceed that which is normally possessed by a prudent person in the ordinary course of business dealings.
- F. The Offeror agrees that, if awarded a contract resulting from this solicitation, it will incorporate this provision for certification without modification in all lower tier subcontracts. The contractor may rely on the certification of a prospective subcontractor that it is not a firm from a foreign country included on the list of countries that discriminate against U.S. firms as published by U.S.T.R, unless the Offeror has knowledge that the certification is erroneous.
- G. The Contractor shall provide immediate written notice to the Sponsor if the contractor learns that its certification or that of a subcontractor was erroneous when submitted or has become erroneous by reason of changed circumstances. The subcontractor agrees to provide immediate written notice to the Contractor, if at any time it learns that its certification was erroneous by reason of changed circumstances.
- H. This certification is a material representation of fact upon which reliance was placed when making an award. If it is later determined that the Contractor or subcontractor knowingly rendered an erroneous certification, the Federal Aviation Administration may direct through the Owner cancellation of the contract or subcontract for default at no cost to the Owner or the FAA.
- I. Nothing contained in the foregoing shall be construed to require establishment of a system of records in order to render, in good faith, the certification required by this Provision. The knowledge and information of a contractor is not required to exceed that which is normally possessed by a prudent person in the ordinary course of business dealings.
- J. This certification concerns a matter within the jurisdiction of an agency of the United States of America and the making of a false, fictitious, or fraudulent certification may render the maker subject to persecution under **Title 18, United States Code, Section 1001**.

FAA-1.13 EEO Notice to be Posted

NOTICES TO BE POSTED PER PARAGRAPHS (A.1)
AND (A.3) OF THE EEO CLAUSE

Equal Employment Opportunity is the
Law – Discrimination is Prohibited by
the Civil Rights Act of 1964 and by
Executive Order No. 11246

Title VII of the Civil Rights Act of 1964
Administered by:

THE EQUAL EMPLOYMENT OPPORTUNITY
COMMISSION

Prohibits discrimination because of
Race, Color, Religion, Sex, or National
Origin by Employers with 75 or more
employees, by Labor organizations
with a hiring hall of 75 or more
members, by Employment Agencies
and by Joint Labor Management
Committees for Apprenticeship
or Training. After July 1, 1967,
employees and labor organizations
with 50 or more employees or members
will be covered: after July 1, 1968
those with 25 or more will be covered.

ANY PERSON

Who believes he or she has been
Discriminated against

SHOULD CONTACT

THE EQUAL EMPLOYMENT OPPORTUNITY
COMMISSION

1800 G Street NW, Washington D.C. 20506

Executive Order No. 11246
Administered by:

THE OFFICE OF FEDERAL CONTRACT
COMPLIANCE

Prohibits discrimination because of
Race, Color, Religion, Sex, or
National Origin, and requires
affirmative action to ensure equality
of opportunity in all aspects of employment.
By all Federal Government Contractors
and Subcontractors, and by Contractors
Performing Work Under a Federal
Assisted Construction Contract, regardless
of the number of employees in
either case.

ANY PERSON

Who believes he or she has been
discriminated against

SHOULD CONTACT

THE OFFICE OF FEDERAL CONTRACT
COMPLIANCE

U.S. Department of Labor
Washington, D.C. 20210

SECTION 2 DAVIS-BACON REQUIREMENTS

FAA-2.01 Minimum Wages

- A. All laborers and mechanics employed or working upon the site of the work will be paid unconditionally and not less often than once a week, and without subsequent deduction or rebate on any account (except such payroll deductions as are permitted by the Secretary of Labor under the Copeland Act (29 CFR Part 3)), the full amount of wages and bona fide fringe benefits (or cash equivalent thereof) due at time of payment computed at rates not less than those contained in the wage determination of the Secretary of Labor which is attached hereto and made a part hereof, regardless of any contractual relationship which may be alleged to exist between the contractor and such laborers and mechanics.

Contributions made or costs reasonably anticipated for bona fide fringe benefits under **section 1(b)(2) of the Davis-Bacon Act** on behalf of laborers or mechanics are considered wages paid to such laborers or mechanics, subject to the provisions of paragraph (1)(iv) of this section; also, regular contributions made or costs incurred for more than a weekly period (but not less often than quarterly) under plans, funds, or programs which cover the particular weekly period, are deemed to be constructively made or incurred during such weekly period. Such laborers and mechanics shall be paid the appropriate wage rate and fringe benefits on the wage determination for the classification of work actually performed, without regard to skill, except as provided in 29 CFR Part 5.5(a)(4). Laborers or mechanics performing work in more than one classification may be compensated at the rate specified for each classification for the time actually worked therein: Provided, that the employer's payroll records accurately set forth the time spent in each classification in which work is performed. The wage determination (including any additional classification and wage rates conformed under (1)(ii) of this section) and the **Davis-Bacon poster (WH-1321)** shall be posted at all times by the contractor and its subcontractors at the site of the work in a prominent and accessible place where it can easily be seen by the workers.

- B. The Contracting Officer shall require that any class of laborers or mechanics including helpers, which is not listed in the wage determination and which is to be employed under the Contract shall be classified in conformance with the wage determination. The Contracting Officer shall approve an additional classification and wage rate and fringe benefits therefore only when the following criteria have been met:
1. The work to be performed by the classification requested is not performed by a classification in the wage determination; and

2. The classification is utilized in the area by the construction industry; and
 3. The proposed wage rate, including any bona fide fringe benefits, bears a reasonable relationship to the wage rates contained in the wage determination; and
- C. If the Contractor and the laborers and mechanics to be employed in the classification (if known), or their representatives, and the Contracting Officer agree on the classification and wage rate (including the amount designated for fringe benefits where appropriate), a report of the action taken shall be sent by the Contracting Officer to the Administrator of the Wage And Hour Division, Employment Standards Administration, U.S. Department of Labor, Washington D.C. 20210. The Administrator, or an authorized representative, will approve, modify, or disapprove every additional classification action within 30 days of receipt and so advised the Contracting Officer or will notify the Contracting Officer within the 30-day period that additional time is necessary.
- D. In the event the Contractor, the laborers or mechanics to be employed in the classification or their representatives, and the Contracting Officer do not agree on the proposed classification and wage rate (including the amount designated for fringe benefits, where appropriate), the Contracting Officer shall refer the questions, including the views of all interested parties and the recommendation of the Contracting Officer, to the Administrator for determination. The Administrator, or an authorized representative, will issue a determination within thirty (30) days of receipt and so advise the Contracting Officer or will notify the Contracting Officer within the 30-day period that additional time is necessary.
- E. The wage rate (including fringe benefits where appropriate) determined pursuant to Subparagraphs B, C or D of this Paragraph shall be paid to all workers performing work in the classification under this Contract from the first day on which work is performed in the classification.
1. Whenever the minimum wage rate prescribed in the Contract for a class or laborers or mechanics includes a fringe benefit which is not expressed as an hourly rate, the Contractor shall either pay the benefit as stated in the wage determination or shall pay another bona fide fringe benefit or an hourly cash equivalent thereof.
 2. If the Contractor does not make payments to a trustee or other third person, the Contractor may consider as part of the wages of any laborer or mechanic the amount of any costs reasonably anticipated in providing bona fide fringe benefits under a plan or program, provided, that the Secretary of Labor has found, upon the written request of the Contractor, that the applicable standards of the Davis-Bacon Act have been met. The Secretary of Labor may require the Contractor to set aside in a separate account assets for the meeting of obligations under the plan or program.

FAA-2.02 Withholding

- A. The Federal Aviation Administration or the sponsor shall upon its own action or upon written request of an authorized representative of the Department of Labor withhold or cause to be withheld from the contractor under this contract or any other Federal contract with the same prime contractor, or any other Federally-assisted contract subject to Davis-Bacon prevailing wage requirements, which is held by the same prime contractor, so much of the accrued payments or advances as may be considered necessary to pay laborers and mechanics, including apprentices, trainees, and helpers, employed by the contractor or any subcontractor the full amount of wages required by the contract.
- B. In the event of failure to pay any laborer or mechanic, including any apprentice, trainee, or helper, employed or working on the site of work, all or part of the wages required by the contract, the Federal Aviation Administration may, after written notice to the contractor, sponsor, applicant, or owner, take such action as may be necessary to cause the suspension of any further payment, advance, or guarantee of funds until such violations have ceased.

FAA-2.03 Payrolls and Basic Records

- A. Payrolls and basic records relating thereto shall be maintained by the contractor during the course of the work and preserved for a period of three years thereafter for all laborers and mechanics working at the site of the work. Such records shall contain the name, address, and social security number of each such worker, his or her correct classification, hourly rates of wages paid (including rates of contributions or costs anticipated for bona fide fringe benefits or cash equivalents thereof of the types described in 1(b)(2)(B) of the Davis-Bacon Act), daily and weekly number of hours worked, deductions made and actual wages paid.
- B. Whenever the Secretary of Labor has found under 29 CFR 5.5(a)(1)(iv) that the wages of any laborer or mechanic include the amount of any costs reasonably anticipated in providing benefits under a plan or program described in section 1(b)(2)(B) of the Davis-Bacon Act, the contractor shall maintain records which show that the commitment to provide such benefits is enforceable, that the plan or program is financially responsible, and that the plan or program has been communicated in writing to the laborers or mechanics affected, and records which show the costs anticipated or the actual costs incurred in providing such benefits. Contractors employing apprentices or trainees under approved programs shall maintain written evidence of the registration of apprenticeship programs and certification of trainee programs, the registration of the apprentices and trainees, and the ratios and wage rates prescribed in the applicable programs.

- C. The contractor shall submit weekly for each week in which any contract work is performed a copy of all payrolls to the Federal Aviation Administration if the agency is a party to the contract, but if the agency is not such a party, the contractor will submit the payrolls to the applicant, sponsor, or owner, as the case may be, for transmission to the Federal Aviation Administration. The payrolls submitted shall set out accurately and completely all of the information required to be maintained under 29 CFR 5.5(a)(3)(i), except that full social security numbers and home addresses shall not be included on weekly transmittals. Instead the payrolls shall only need to include an individually identifying number for each employee (e.g. , the last four digits of the employee's social security number). The required weekly payroll information may be submitted in any form desired. Optional Form WH-347 is available for this purpose from the Wage and Hour Division Web site at <http://www.dol.gov/esa/whd/forms/wh347instr.htm> or its successor site. The prime contractor is responsible for the submission of copies of payrolls by all subcontractors. Contractors and subcontractors shall maintain the full social security number and current address of each covered worker, and shall provide them upon request to the Federal Aviation Administration if the agency is a party to the contract, but if the agency is not such a party, the contractor will submit them to the applicant, sponsor, or owner, as the case may be, for transmission to the Federal Aviation Administration, the contractor, or the Wage and Hour Division of the Department of Labor for purposes of an investigation or audit of compliance with prevailing wage requirements. It is not a violation of this section for a prime contractor to require a subcontractor to provide addresses and social security numbers to the prime contractor for its own records, without weekly submission to the sponsoring government agency (or the applicant, sponsor, or owner).
1. Each payroll submitted shall be accompanied by a "Statement of Compliance," signed by the contractor or subcontractor or his or her agent who pays or supervises the payment of the persons employed under the contract and shall certify the following:
 - a. That the payroll for the payroll period contains the information required to be provided under 29 CFR § 5.5(a)(3)(ii), the appropriate information is being maintained under 29 CFR § 5.5 (a)(3)(i) and that such information is correct and complete;
 - b. That each laborer and mechanic (including each helper, apprentice and trainee) employed on the contract during the payroll period has been paid the full weekly wages earned, without rebate, either directly or indirectly, and that no deductions have been made either directly or indirectly from the full wages earned, other than permissible deductions as set forth in Regulations 29 CFR Part 3;
 - c. That each laborer or mechanic has been paid not less than the applicable wage rates and fringe benefits or cash equivalents for the

classification of work performed, as specified in the applicable wage determination incorporated into the contract.

2. The weekly submission of a properly executed certification set forth on the reverse side of Optional Form WH-347 shall satisfy the requirement for submission of the "Statement of Compliance" required by paragraph (3)(ii)(B) of this section.
 3. The falsification of any of the above certifications may subject the contractor or subcontractor to civil or criminal prosecution under Section 1001 of Title 18 of the United States Code.
- D. The contractor or subcontractor shall make the records required under paragraph (3)(i) of this section available for inspection, copying or transcription by authorized representatives of the sponsor, the Federal Aviation Administration or the Department of Labor, and shall permit such representatives to interview employees during working hours on the job. If the contractor or subcontractor fails to submit the required records or to make them available, the Federal agency may, after written notice to the contractor, sponsor, applicant or owner, take such action as may be necessary to cause the suspension of any further payment, advance, or guarantee of funds. Furthermore, failure to submit the required records upon request or to make such records available may be grounds for debarment action pursuant to 29 CFR 5.12.

FAA-2.04 Apprentices and Trainees

- A. Apprentices. Apprentices will be permitted to work at less than the predetermined rate for the work they performed when they are employed pursuant to and individually registered in a bona fide apprenticeship program registered with the U.S. Department of Labor, Employment and Training Administration, Bureau of Apprenticeship and Training, or with a State Apprenticeship Agency recognized by the Bureau, or if a person is employed in his or her first 90 days of probationary employment as an apprentice in such an apprenticeship program, who is not individually registered in the program, but who has been certified by the Bureau of Apprenticeship and Training or a State Apprenticeship Agency (where appropriate) to be eligible for probationary employment as an apprentice.
1. The allowable ratio of apprentices to journeymen on the job site in any craft classification shall not be greater than the ratio permitted to the contractor as to the entire work force under the registered program.
 2. Any worker listed on a payroll at an apprentice wage rate, who is not registered or otherwise employed as stated above, shall be paid not less than the applicable wage rate on the wage determination for the classification of work actually performed. In addition, any apprentice performing work on the job site in excess of the ratio permitted under the

registered program shall be paid not less than the applicable wage rate on the wage determination for the work actually performed.

3. Where a contractor is performing construction on a project in a locality other than that in which its program is registered, the ratios and wage rates (expressed in percentages of the journeyman's hourly rate) specified in the contractor's or subcontractor's registered program shall be observed. Every apprentice must be paid at not less than the rate specified in the registered program for the apprentice's level of progress, expressed as a percentage of the journeymen hourly rate specified in the applicable wage determination.
 4. Apprentices shall be paid fringe benefits in accordance with the provisions of the apprenticeship program. If the apprenticeship program does not specify fringe benefits, apprentices must be paid the full amount of fringe benefits listed on the wage determination for the applicable classification. If the Administrator determines that a different practice prevails for the applicable apprentice classification, fringes shall be paid in accordance with that determination.
 5. In the event the Bureau of Apprenticeship and Training, or a State Apprenticeship Agency recognized by the Bureau, withdraws approval of an apprenticeship program, the contractor will no longer be permitted to utilize apprentices at less than the applicable predetermined rate for the work performed until an acceptable program is approved.
- B. Trainees. Except as provided in 29 CFR 5.16, trainees will not be permitted to work at less than the predetermined rate for the work performed unless they are employed pursuant to and individually registered in a program which has received prior approval, evidenced by formal certification by the U.S. Department of Labor, Employment and Training Administration.
1. The ratio of trainees to journeymen on the job site shall not be greater than permitted under the plan approved by the Employment and Training Administration.
 2. Every trainee must be paid at not less than the rate specified in the approved program for the trainee's level of progress, expressed as a percentage of the journeyman hourly rate specified in the applicable wage determination.
 3. Trainees shall be paid fringe benefits in accordance with the provisions of the trainee program. If the trainee program does not mention fringe benefits, trainees shall be paid the full amount of fringe benefits listed on the wage determination unless the Administrator of the Wage and Hour Division determines that there is an apprenticeship program associated with the

corresponding journeyman wage rate on the wage determination which provides for less than full fringe benefits for apprentices.

4. Any employee listed on the payroll at a trainee rate that is not registered and participating in a training plan approved by the Employment and Training Administration shall be paid not less than the applicable wage rate on the wage determination for the classification of work actually performed. In addition, any trainee performing work on the job site in excess of the ratio permitted under the registered program shall be paid not less than the applicable wage rate on the wage determination for the work actually performed. In the event the Employment and Training Administration withdraws approval of a training program, the contractor will no longer be permitted to utilize trainees at less than the applicable predetermined rate for the work performed until an acceptable program is approved.
- C. **Equal Employment Opportunity.** The utilization of apprentices, trainees and journeymen under this part shall be in conformity with the equal employment opportunity requirements of Executive Order 11246, as amended, and 29 CFR Part 30.
- D. **Helpers.** Helpers will be permitted to work on a project if the helper classification is specified on an applicable wage determination or is approved pursuant to the conformance procedure set forth in subparagraph 5.5 (a)(1)(ii) of this Section.
1. The allowable ration of helpers to journeymen employed by the Contractor or subcontractor on the job site shall not be greater than two (2) helpers for every three (3) journeymen (in other words, not more than forty percent (40%) of the total number of journeymen and helpers in each contractor's or in each subcontractor's own work force employed on the job site).
 2. Any worker listed on a payroll at a helper wage rate, who is not a helper as defined in **29 CFR 5.2 (n) (4)**, shall be paid not less than the applicable wage rate on the wage determination for classification of work actually performed. In addition, any helper performing work on the job site in excess of the ratio permitted shall be paid not less than the applicable journeyman's (or laborer's, where appropriate) wage rate on the wage determination for the work actually performed.

FAA-2.05 Compliance with Copeland Act Requirements

The Contractor shall comply with the requirements of **29 CFR Part 3**, which are incorporated by reference in this Contract.

FAA-2.06 Subcontracts

The Contractor or subcontractor shall insert in any subcontracts the clauses contained in **29 CFR 5.5(a)(1) through (10)** and such other clauses as the FAA may, by appropriate instructions require, and also a clause requiring the subcontractors to include these clauses in any lower tier subcontracts. The Prime Contractor shall be responsible for the compliance by any subcontractor or lower tier subcontractor with all the Contract Clauses in **29 CFR 5.5**.

FAA-2.07 Contract Termination: Debarment

A breach of the contract clauses in paragraphs FAA-2.01 through FAA-2.10 of this section may be grounds for termination of the contract, and for debarment as a contractor and a subcontractor as provided in 29 CFR 5.12.

FAA-2.08 Compliance with Davis-Bacon and Related Act Requirements

All rulings and interpretations of the Davis-Bacon and related acts contained in **29 CFR Parts 1, 3, and 5** are herein incorporated by reference in this Contract.

FAA-2.09 Disputes Concerning Labor Standards

Disputes arising out of the labor standards provisions of this Contract shall not be subject to the general disputes clause of this Contract. Such disputes shall be resolved in accordance with the procedures of the Department of Labor set forth in **29 CFR Parts 5, 6, and 7**. Disputes within the meaning of this clause include disputes between the Contractor (or any of its Subcontractors) and the Contracting Agency, the U.S. Department of Labor, or the employees or their representatives.

FAA-2.10 Certification of Eligibility

- A. By entering into this Contract, the Contractor certifies:
1. that neither it (nor he or she) nor any person or firm who has an interest in the contractor's firm is a person or firm ineligible to be awarded Government contracts by virtue of section 3(a) of the Davis-Bacon Act or 29 CFR 5.12(a)(1).
 2. no part of this Contract shall be subcontracted to any person or firm ineligible for award of a Government contract by virtue of **Section 3(a) of the Davis-Bacon Act or 29 CFR 5.12(A)(1)**.

- B. The penalty for making false statements is prescribed in the **U.S. Criminal Code, 18 U.S.C. 1001**.

FAA-2.11 Contractor's Certification of Eligibility

The Contractor is directed to Standard Provisions, Part V, Section 4, Sample Forms for Federal-Aid Contracts, **FAA-4.02**, for a sample of executable form for Certification of Eligibility.

FAA-2.12 Contract Work Hours and Safety Standards Act Requirements

- A. Overtime Requirements. No contractor or subcontractor contracting for any part of the contract work which may require or involve the employment of laborers or mechanics shall require or permit any such laborer or mechanic, including watchmen and guards, in any workweek in which he or she is employed on such work to work in excess of forty hours in such workweek unless such laborer or mechanic receives compensation at a rate not less than one and one-half times the basic rate of pay for all hours worked in excess of forty hours in such workweek.
- B. Violation: Liability for Unpaid Wages: Liquidated Damages. In the event of any violation of the clause set forth in paragraph (1) of this clause, the contractor and any subcontractor responsible therefor shall be liable for the unpaid wages. In addition, such contractor and subcontractor shall be liable to the United States (in the case of work done under contract for the District of Columbia or a territory, to such District or to such territory), for liquidated damages. Such liquidated damages shall be computed with respect to each individual laborer or mechanic, including watchmen and guards, employed in violation of the clause set forth in paragraph (1) of this clause, in the sum of \$10 for each calendar day on which such individual was required or permitted to work in excess of the standard workweek of forty hours without payment of the overtime wages required by the clause set forth in paragraph (1) of this clause.
- C. Withholding for Unpaid Wages and Liquidated Damages. The Federal Aviation Administration (FAA) or the Owner shall upon its own action or upon written request of an authorized representative of the Department of Labor withhold or cause to be withheld, from any moneys payable on account of work performed by the contractor or subcontractor under any such contract or any other Federal contract with the same prime contractor, or any other Federally-assisted contract subject to the Contract Work Hours and Safety Standards Act, which is held by the same prime contractor, such sums as may be determined to be necessary to satisfy any liabilities of such contractor or subcontractor for unpaid wages and liquidated damages as provided in the clause set forth in paragraph 2 of this clause.

- D. Subcontracts. The contractor or subcontractor shall insert in any subcontracts the clauses set forth in paragraphs (1) through (4) and also a clause requiring the subcontractor to include these clauses in any lower tier subcontracts. The prime contractor shall be responsible for compliance by any subcontractor or lower tier subcontractor with the clauses set forth in paragraphs (1) through (4) of this clause.
- E. Payrolls and Basic Records. The Contractor or subcontractor shall maintain payrolls and basic payroll records during the course of the work and shall preserve them for a period of three (3) years from the completion of the Contract for all laborers and mechanics, including guards and watchmen, working in the Contract. Such records shall contain the name and address of each such employee, Social Security Number, correct classifications, hourly rates of wages paid, daily and weekly number of hours worked, deductions made, and actual wages paid. The records to be maintained under this Paragraph shall be made available by the Contractor or subcontractor for inspection, copying, or transcription by the authorized representatives of the DOT, FAA, and the Department of Labor, and the Contractor or subcontractor will permit such representatives to interview employees during working hours on the job.

SECTION 3 BUY AMERICAN CLAUSE

FAA-3.01 Notice to Bidders

- A. The **Aviation Safety and Capacity Expansion Act of 1990** provides that preference be given to steel and manufactured products produced in the United States when funds are expended pursuant to a grant issued under the AIP. The Contractor shall agree that only domestic steel and manufactured products will be delivered and used by the Contractor, subcontractors, materialmen, and suppliers in the performance of this Contract, as defined by the following terms:
1. Steel and Manufactured Products. As used in this Clause, steel and manufactured products included:
 - a. steel produced in the United States, or
 - b. a manufactured product produced in the United States, if the cost of its components mined, produced, or manufactured in the United States exceeds sixty percent (60%) of the cost of all its components and final assembly has taken place in the United States.
 - c. components of foreign origin of the same class of kind as the products referred to in subparagraphs 1.a. or 1.b. shall be treated as domestic.
 2. Components. As used in this Clause, components means those articles, materials, and suppliers incorporated directly into steel and manufactured products.
 3. Cost of Components. This means the costs for production of the components, exclusive of final assembly labor costs.
- B. The successful bidder will be required to assure that only domestic steel and manufactured products will be delivered and used by the Contractor, subcontractors, materialmen, and suppliers in the performance of this Contract, except those:
1. that the U.S. Department of Transportation has determined, under the **Aviation Safety and Capacity Expansion Act of 1990**, are not produced in the United States in sufficient and reasonably available quantities and of a satisfactory quality;

2. that the U.S. Department of Transportation has determined, under the **Aviation Safety and Capacity Expansion Act of 1990**, that domestic preference would be inconsistent with the public interest; or
3. that inclusion of domestic material will increase the cost of the overall project contract by more than twenty-five (25) percent.

FAA-3.02 List of Supplies/Materials

A. List of Supplies/Materials that the U.S. Government has determined are not produced in the United States in sufficient and reasonably available quantities and of sufficient quality (as of January 1991):

Supplies/Materials	Supplies/Materials	Supplies/Materials
Acetylene, black	Coconut and coconut meat, unsweetened, in shredded, desiccated or similarly prepared form	Manganese
Agar, bulk	Coffee, raw or green bean	Menthol, natural bulk
Anise	Colchicines alkaloid, raw	Mica, brought onto construction site as separate units for incorporation into building systems during construction or repair and alteration of a real property
Antimony, as metal or oxide	Copra	Microprocessor chips
Asbestos, amosite, chrysolite and crocidolite	Cork, wood or bark and waste	Nickel, primary, in ingots, pigs, shots, cathodes, or similar forms; nickel oxide and nickel salts
Bananas	Cover glass, microscope slide	Nux vomica, crude
Bauxite	Cryolite, natural	Nitrguanidine (also known as pricrite)
Beef, corned, canned	Dammar gum	Olives (green, pitted or unpitted, Olive oil
Beef extract	Diamonds, industrial, stones, and abrasives	Oiticica oil
Bephemium Hydroxynapthoatey	Emetine, bulk	Oranges, mandarin, canned or stuffed, in bulk
Bismuth	Erthrityl tetranitrate	Opium, crude
Books, trade, text, technical, or scientific; newspapers; pamphlets; magazines; periodicals; printed briefs and films; not printed in the United States and for which domestic editions are not available	Ergot, crude	Petroleum, crude oil, unfinished oils, and finished products (see definitions below)
Brazil nuts, unroasted	Fibers of the following types: abaca, abace, agave, coir, flex, jute, jute burlaps, palmyra and sisal	Pine needle oil
Cadmium, ores and flue dust	Fair linen, altar	Platinum and related group metals, refined, as sponge, powder, ingots or cast bars
Calcium cyanamide	Goat and kidskins	Pyrethrum flowers
Capers	Graphite, natural, crystalline, crucible grade	Quartz crystals
Cashew nuts	Handsewing needles	Quebracho
Castor beans or castor oil	Hyoscine, bulk	Quinidine
Chalk, English	Hog bristles for brushes	Quinine
Chestnuts	Hemp, yarn	
Chicle	Iodine, crude	
Chrome ore or chromite	Ipecac, root	
Cinchona bark	Kasurigum	
Cobalt, in cathodes, rondelles, or other primary ore and metal forms	Leather, sheepskin, hair type	
Cocoa beans	Lac	
	Lavender oil	

Supplies/Materials	Supplies/Materials	Supplies/Materials
Rabbit fur felt Radium salts, source and special nuclear materials Rosettes Rubber, crude and latex Rustile Santonin, crude Secretin Shellac Silk, raw and unmanufactured Spare and replacement parts for equipment of foreign manufacture, and for which domestic parts are not available	Spices and herbs, in bulk Sugars, raw Swords and scabbards Talc, block, steatite Tantalum Tapioca flour and cassava Tartar, cured; tartaric acid and cream of tartar in bulk Tea in bulk Thread, metallic (gold) Thyme oil Tin in bars, blocks, and pigs Tripolidine hydrochloride Tungsten Vanilla beans Venom, cobra	Wax cabayba Woods; logs, veneer and lumber of the following species: Alaskan yellow cedar, Angelique, balsa, ekki, greenheart, lignum vitae, mahogany, and teak Yarn, 50 Denier rayon

B. Petroleum terms are used as follows:

Crude Oil means crude petroleum, as it is produced at the wellhead and liquids (under atmospheric conditions) that have been recovered from mixtures of hydrocarbons that existed in a vaporous phase in a reservoir and that are not natural gas products.

Finished Products means any one or more of the following petroleum oils, or a mixture or combination of these oils, to be used without further processing except blending by mechanical means.

Asphalt a solid or semi-solid cementitious material that (1) gradually liquefies when heated, (2) has bitumens as its predominating constituents and (3) is obtained in refining crude oil.

Fuel Oil a liquid or liquefiable petroleum product burned for lighting or for the generation of heat or power and derived directly or indirectly from crude oil, such as kerosene, range oil, distillate fuel oils, gas oil, diesel fuel, topped crude oil, or residues.

Gasoline a refined petroleum distillate that, by its consumption, is suitable for use as a carburant in internal combustion engines.

Jet Fuel a refined petroleum distillate used to fuel jet propulsion engines.

Liquefied Gases hydrocarbon gases recovered from natural gas or produced from petroleum refining and kept under pressure to maintain a liquid state at ambient temperatures.

Lubricating Oil a refined petroleum distillate or specially treated petroleum residue used to lessen friction between surfaces.

Naphtha a refined petroleum distillate falling within a distillation range overlapping the higher gasoline and the lower kerosenes.

Natural Gas Products liquids (Under atmospheric conditions) including natural gasoline, that

1. are recovered by a process of absorption, adsorption, compression, refrigeration, cycling, or a combination of these processes, from mixtures or hydrocarbons that existed in a vaporous phase in a reservoir, and
2. when recovered and without processing in a refinery, definitions of products contained in above for Finished Products, Asphalt, and Liquefied Gases.

Residual Fuel Oil a topped crude oil or viscous residuum that, as obtained in refining or after blending with other fuel oil, meets or is the equivalent of MILSPEC Mil-F-859 for Navy Special Fuel Oil and any more viscous fuel oil, such as No. 5 or Bunker C.

Unfinished Oils means one or more of the petroleum oils listed under “Finished products” above, or a mixture of combination of these oils, that are to be further processed other than by blending by mechanical means.

FAA-3.03 Buy American Certification

The Contractor is directed to Standard Provisions, Part V, Section 4, Sample Forms for Federal-Aid Contracts, **FAA-4.03**, for a sample of executable form for Buy American Certification.

SECTION 4

SAMPLE FORMS FOR FEDERAL-AID CONTRACTS

FAA-4.01	Prohibition of Segregated Facilities (FAA-1.03).....	230
FAA-4.02	Contractor’s Certification of Eligibility (FAA-2.11)	231
FAA-4.03	Buy American Certification (FAA-3.03).....	232
FAA-4.04	Contractor’s Certification of a Drug-Free Workplace.....	236
FAA-4.05	Certification of Federal-Aid Contracts.....	238
FAA-4.06	Disadvantaged Business Enterprises.....	239
FAA-4.07	Texting When Driving	239
FAA-4.08	Occupational Safety and Health Act of 1970	240
FAA-4.09	Procurement of Recovered Materials.....	240
FAA-4.10	Title VI List of Pertinent Nondiscrimination Acts and Authorities	241
FAA-4.11	Copeland “Anti-Kickback” Act	242
FAA-4.12	Energy Conservation Requirements.....	242
FAA-4.13	Termination for Default (Construction)	242
FAA-4.14	Termination for Default (Equipment)	243

FAA-4.01 Prohibition of Segregated Facilities (FAA-1.03)

- A. The Contractor agrees that it does not and will not maintain or provide for its employees any segregated facilities at any of its establishments, and that it does not and will not permit its employees to perform their services at any location under its control where segregated facilities are maintained. The Contractor agrees that a breach of this clause is a violation of the Equal Opportunity clause in this contract.
- B. "Segregated facilities," as used in this clause, means any waiting rooms, work areas, rest rooms and wash rooms, restaurants and other eating areas, time clocks, locker rooms and other storage or dressing areas, parking lots, drinking fountains, recreation or entertainment areas, transportation, and housing facilities provided for employees, that are segregated by explicit directive or are in fact segregated on the basis of race, color, religion, sex, or national origin because of written or oral policies or employee custom. The term does not include separate or single-user rest rooms or necessary dressing or sleeping areas provided to assure privacy between the sexes.
- C. The Contractor shall include this clause in every subcontract and purchase order that is subject to the Equal Opportunity clause of this contract.
- D. The information above is true and complete to the best of my knowledge.

_____	_____
Printed Name	Title
_____	_____
Signature	Date

- NOTE:
- 1. The penalty for making false statements in offers is prescribed in **U.S. Criminal Code, 18 U.S.C. 1001.**
 - 2. Refer to Standard Provisions, Part V, Section 1, FAA Requirements for Federal-Aid Contracts for additional requirements.

FAA-4.02 Contractor's Certification of Eligibility (FAA-2.11)

The Bidder/Offeror certifies, by submission of this proposal or acceptance of this Contract:

- A. That neither it nor its principals is presently debarred, suspended, proposed for debarment, declared ineligible, or voluntarily excluded from participation in this transaction by any Federal department or agency.
- B. It further agrees by submitting this proposal that it will include this clause without modification in all lower tier transactions, solicitations, proposal, contracts, and subcontracts. Where the Bidder/Offeror/Contractor or any lower tier participant is unable to certify to this statement, it shall attach an explanation to this Solicitation/Proposal.
- C. That, the information above is true and complete to the best of my knowledge.

_____	_____
Printed Name	Title
_____	_____
Signature	Date

- NOTE:
- 1. The penalty for making false statements in offers is prescribed in **U.S. Criminal Code, 18 U.S.C. 1001.**
 - 2. Refer to Standard Provisions, Part V, Section 2, Secretary of Labor Requirements, for additional requirements.

FAA-4.03 Buy American Certification (FAA-3.03)

CERTIFICATE OF BUY AMERICAN COMPLIANCE FOR TOTAL FACILITY

As a matter of bid responsiveness, the bidder or offeror must complete, sign, date, and submit this certification statement with their proposal. The bidder or offeror must indicate how they intend to comply with 49 USC § 50101 by selecting one of the following certification statements. These statements are mutually exclusive. Bidder must select one or the other (i.e. not both) by inserting a checkmark (✓) or the letter "X".

- Bidder or offeror hereby certifies that it will comply with 49 USC. 50101 by:
- a) Only installing steel and manufactured products produced in the United States; or
 - b) Installing manufactured products for which the FAA has issued a waiver as indicated by inclusion on the current FAA Nationwide Buy American Waivers Issued listing; or
 - c) Installing products listed as an Excepted Article, Material or Supply in Federal Acquisition Regulation Subpart 25.108.

By selecting this certification statement, the bidder or offeror agrees:

1. To provide to the Owner evidence that documents the source and origin of the steel and manufactured product.
 2. To faithfully comply with providing US domestic products.
 3. To refrain from seeking a waiver request after establishment of the contract, unless extenuating circumstances emerge that the FAA determines justified.
- The bidder or offeror hereby certifies it cannot comply with the 100% Buy American Preferences of 49 USC § 50101(a) but may qualify for either a Type 3 or Type 4 waiver under 49 USC § 50101(b). By selecting this certification statement, the apparent bidder or offeror with the apparent low bid agrees:
1. To the submit to the Owner within 15 calendar days of the bid opening, a formal waiver request and required documentation that support the type of waiver being requested.
 2. That failure to submit the required documentation within the specified timeframe is cause for a non-responsive determination that may result in rejection of the proposal.
 3. To faithfully comply with providing US domestic products at or above the approved US domestic content percentage as approved by the FAA.
 4. To furnish US domestic product for any waiver request that the FAA rejects.

5. To refrain from seeking a waiver request after establishment of the contract, unless extenuating circumstances emerge that the FAA determines justified.

Required Documentation

Type 3 Waiver - The cost of components and subcomponents produced in the United States is more than 60% of the cost of all components and subcomponents of the “facility”. The required documentation for a type 3 waiver is:

- a) Listing of all manufactured products that are not comprised of 100% US domestic content (Excludes products listed on the FAA Nationwide Buy American Waivers Issued listing and products excluded by Federal Acquisition Regulation Subpart 25.108; products of unknown origin must be considered as non-domestic products in their entirety)
- b) Cost of non-domestic components and subcomponents, excluding labor costs associated with final assembly and installation at project location.
- c) Percentage of non-domestic component and subcomponent cost as compared to total “facility” component and subcomponent costs, excluding labor costs associated with final assembly and installation at project location.

Type 4 Waiver – Total cost of project using US domestic source product exceeds the total project cost using non-domestic product by 25%. The required documentation for a type 4 of waiver is:

- a) Detailed cost information for total project using US domestic product
- b) Detailed cost information for total project using non-domestic product

False Statements: Per 49 USC § 47126, this certification concerns a matter within the jurisdiction of the Federal Aviation Administration and the making of a false, fictitious or fraudulent certification may render the maker subject to prosecution under Title 18, United States Code.

Date

Signature

Company Name

Title

Certificate of Buy American Compliance for Manufactured Products

As a matter of bid responsiveness, the bidder or offeror must complete, sign, date, and submit this certification statement with their proposal. The bidder or offeror must indicate how they intend to comply with 49 USC § 50101 by selecting one on the following certification statements. These statements are mutually exclusive. Bidder must select one or the other (not both) by inserting a checkmark (✓) or the letter "X".

- Bidder or offeror hereby certifies that it will comply with 49 USC § 50101 by:
- a) Only installing steel and manufactured products produced in the United States, or;
 - b) Installing manufactured products for which the FAA has issued a waiver as indicated by inclusion on the current FAA Nationwide Buy American Waivers Issued listing, or;
 - c) Installing products listed as an Excepted Article, Material or Supply in Federal Acquisition Regulation Subpart 25.108.

By selecting this certification statement, the bidder or offeror agrees:

1. To provide to the Owner evidence that documents the source and origin of the steel and manufactured product.
 2. To faithfully comply with providing US domestic product
 3. To furnish US domestic product for any waiver request that the FAA rejects
 4. To refrain from seeking a waiver request after establishment of the contract, unless extenuating circumstances emerge that the FAA determines justified.
- The bidder or offeror hereby certifies it cannot comply with the 100% Buy American Preferences of 49 USC § 50101(a) but may qualify for either a Type 3 or Type 4 waiver under 49 USC § 50101(b). By selecting this certification statement, the apparent bidder or offeror with the apparent low bid agrees:
1. To the submit to the Owner within 15 calendar days of the bid opening, a formal waiver request and required documentation that support the type of waiver being requested.
 2. That failure to submit the required documentation within the specified timeframe is cause for a non-responsive determination may result in rejection of the proposal.
 3. To faithfully comply with providing US domestic products at or above the approved US domestic content percentage as approved by the FAA.
 4. To refrain from seeking a waiver request after establishment of the contract, unless extenuating circumstances emerge that the FAA determines justified.

Required Documentation

Type 3 Waiver - The cost of the item components and subcomponents produced in the United States is more than 60% of the cost of all components and subcomponents of the "item". The required documentation for a type 3 waiver is:

- a) Listing of all product components and subcomponents that are not comprised of 100% US domestic content (Excludes products listed on the FAA Nationwide Buy American Waivers Issued listing and products excluded by Federal Acquisition Regulation Subpart 25.108; products of unknown origin must be considered as non-domestic products in their entirety).
- b) Cost of non-domestic components and subcomponents, excluding labor costs associated with final assembly at place of manufacture.
- c) Percentage of non-domestic component and subcomponent cost as compared to total "item" component and subcomponent costs, excluding labor costs associated with final assembly at place of manufacture.

Type 4 Waiver – Total cost of project using US domestic source product exceeds the total project cost using non-domestic product by 25%. The required documentation for a type 4 waiver is:

- a) Detailed cost information for total project using US domestic product
- b) Detailed cost information for total project using non-domestic product

False Statements: Per 49 USC § 47126, this certification concerns a matter within the jurisdiction of the Federal Aviation Administration and the making of a false, fictitious or fraudulent certification may render the maker subject to prosecution under Title 18, United States Code.

Date

Signature

Company Name

Title

FAA-4.04 Contractor's Certification of a Drug-Free Workplace

STATE OF: _____

COUNTY OF: _____

- A. The undersigned being first duly sworn, under oath, deposes and says:
1. He/she is a federally assisted contractor and makes this certification pursuant to the requirements of the Federal Anti-Drug Abuse Act of 1988;
 2. He/she will provide a workplace free from illegal drugs;
 3. In order to comply with Title V(D), the undersigned certifies that he/she has:
 - a. published notice to employees that illegal drugs ("drugs") are prohibited in the workplace and specified sanctions for violations;
 - b. established a drug-free awareness program to inform employees about the danger of illegal drugs, the employer's drug-free policy, the availability of counseling and treatment and the penalties of violations;
 - c. made it a requirement that employees, as a condition of employment abide by the notice and notify the employer of any conviction for violation of any drug statute for a workplace violation no later than five (5) days after such conviction.
- B. The undersigned further certifies that he/she will:
1. notify the granting or contracting agency of an employee's conviction within ten (10) days after notice from the employee;
 2. impose sanctions on, or require treatment of a convicted employee; and
 3. make a good faith effort to maintain a drug-free workplace.

The undersigned states that the above information is true and complete to the best of his/her knowledge.

Firm Name

Printed Name

Title

Date

Signature

SUBSCRIBED AND SWORN before me, a Notary Public:

this _____ day of _____, 20_____

Notary Public _____

NOTE: The penalty for making false statements in offers is prescribed in **U.S. Criminal Code, 18 U.S.C. 1001.**

FAA-4.05 Certification for Federal-Aid Contracts

- A. The prospective participant certifies, by signing and submitting this bid or proposal, to the best of his or her knowledge and belief, that:
1. No Federal appropriated funds have been paid or will be paid, by or on behalf of the undersigned, to any person for influencing or attempting to influence an officer or employee of any Federal agency, a Member of Congress, an officer or employee of Congress, or an employee of a Member of Congress in connection with the awarding of any Federal contract, the making of any Federal grant, the making of any Federal loan, the entering into of any cooperative agreement, and the extension, continuation, renewal, amendment, or modification of any Federal contract, grant, loan, or cooperative agreement.
 2. If any funds other than Federal appropriated funds have been paid or will be paid to any person for influencing or attempting to influence an officer or employee of any Federal agency, a Member of Congress, an officer or employee of Congress, or an employee of a Member of Congress in connection with this Federal contract, grant, loan, or cooperative agreement, the undersigned shall complete and submit Standard Form-LLL, "Disclosure Form to Report Lobbying", in accordance with its instructions.
- B. This certification is a material representation of fact upon which reliance was placed when this transaction was made or entered into. Submissions of this certification is a prerequisite for making or entering into this transaction imposed by **Section 1352, Title 31, U.S. Code**. Any person who fails to file the required certification shall be subject to a civil penalty of not less than TEN THOUSAND DOLLARS (\$10,000.00) and not more than ONE HUNDRED THOUSAND DOLLARS (\$100,000.00) for each such failure.
- C. The prospective participant also agrees by submitting his or her bid or proposal that he or she shall require that the language of this certification be included in all lower tier subcontracts which exceed ONE HUNDRED THOUSAND DOLLARS (\$100,000.00) and that all such subrecipients shall certify and disclose accordingly.

_____	_____
By	Title
_____	_____
Firm Name	Date

FAA-4.06 Disadvantaged Business Enterprises

- A. **Contract Assurance (§ 26.13)** - The contractor or subcontractor shall not discriminate on the basis of race, color, national origin, or sex in the performance of this contract. The contractor shall carry out applicable requirements of 49 CFR Part 26 in the award and administration of DOT assisted contracts. Failure by the contractor to carry out these requirements is a material breach of this contract, which may result in the termination of this contract or such other remedy, as the recipient deems appropriate.
- B. **Prompt Payment (§26.29)** - The prime contractor agrees to pay each subcontractor under this prime contract for satisfactory performance of its contract no later than {specify number} days from the receipt of each payment the prime contractor receives from {Name of recipient}. The prime contractor agrees further to return retainage payments to each subcontractor within {specify the same number as above} days after the subcontractor's work is satisfactorily completed. Any delay or postponement of payment from the above referenced time frame may occur only for good cause following written approval of the {Name of Recipient}. This clause applies to both DBE and non-DBE subcontractors.

FAA-4.07 Texting When Driving

- A. In accordance with Executive Order 13513, "Federal Leadership on Reducing Text Messaging While Driving" (10/1/2009) and DOT Order 3902.10 "Text Messaging While Driving" (12/30/2009), the FAA encourages recipients of Federal grant funds to adopt and enforce safety policies that decrease crashes by distracted drivers, including policies to ban text messaging while driving when performing work related to a grant or sub-grant.
- B. In support of this initiative, the Owner encourages the Contractor to promote policies and initiatives for its employees and other work personnel that decrease crashes by distracted drivers, including policies that ban text messaging while driving motor vehicles while performing work activities associated with the project. The Contractor must include the substance of this clause in all sub-tier contracts exceeding \$3,500 and involve driving a motor vehicle in performance of work activities associated with the project.

FAA-4.08 Occupational Safety and Health Act of 1970

All contracts and subcontracts that result from this solicitation incorporate by reference the requirements of 29 CFR Part 1910 with the same force and effect as if given in full text. Contractor must provide a work environment that is free from recognized hazards

that may cause death or serious physical harm to the employee. The Contractor retains full responsibility to monitor its compliance and their subcontractor's compliance with the applicable requirements of the Occupational Safety and Health Act of 1970 (20 CFR Part 1910). Contractor must address any claims or disputes that pertain to a referenced requirement directly with the U.S. Department of Labor – Occupational Safety and Health Administration.

FAA-4.09 Procurement of Recovered Materials

- A. Contractor and subcontractor agree to comply with Section 6002 of the Solid Waste Disposal Act, as amended by the Resource Conservation and Recovery Act, and the regulatory provisions of 40 CFR Part 247. In the performance of this contract and to the extent practicable, the Contractor and subcontractors are to use of products containing the highest percentage of recovered materials for items designated by the Environmental Protection Agency (EPA) under 40 CFR Part 247 whenever:
1. The contract requires procurement of \$10,000 or more of a designated item during the fiscal year; or,
 2. The contractor has procured \$10,000 or more of a designated item using Federal funding during the previous fiscal year.
- B. The list of EPA-designated items is available at www.epa.gov/epawaste/consERVE/tools/cpg/products/.
- C. Section 6002(c) establishes exceptions to the preference for recovery of EPA-designated products if the contractor can demonstrate the item is:
1. Not reasonably available within a timeframe providing for compliance with the contract performance schedule;
 2. Fails to meet reasonable contract performance requirements; or
 3. Is only available at an unreasonable price.

FAA-4.10 Title VI List of Pertinent Nondiscrimination Acts and Authorities

- A. During the performance of this contract, the contractor, for itself, its assignees, and successors in interest (hereinafter referred to as the “contractor”) agrees to comply with the following non-discrimination statutes and authorities; including but not limited to:

1. Title VI of the Civil Rights Act of 1964 (42 U.S.C. § 2000d *et seq.*, 78 stat. 252), (prohibits discrimination on the basis of race, color, national origin);
2. 49 CFR part 21 (Non-discrimination In Federally-Assisted Programs of The Department of Transportation—Effectuation of Title VI of The Civil Rights Act of 1964);
3. The Uniform Relocation Assistance and Real Property Acquisition Policies Act of 1970, (42 U.S.C. § 4601), (prohibits unfair treatment of persons displaced or whose property has been acquired because of Federal or Federal-aid programs and projects);
4. Section 504 of the Rehabilitation Act of 1973, (29 U.S.C. § 794 *et seq.*), as amended, (prohibits discrimination on the basis of disability); and 49 CFR part 27;
5. The Age Discrimination Act of 1975, as amended, (42 U.S.C. § 6101 *et seq.*), (prohibits discrimination on the basis of age);
6. Airport and Airway Improvement Act of 1982, (49 USC § 471, Section 47123), as amended, (prohibits discrimination based on race, creed, color, national origin, or sex);
7. The Civil Rights Restoration Act of 1987, (PL 100-209), (Broadened the scope, coverage and applicability of Title VI of the Civil Rights Act of 1964, The Age Discrimination Act of 1975 and Section 504 of the Rehabilitation Act of 1973, by expanding the definition of the terms “programs or activities” to include all of the programs or activities of the Federal-aid recipients, sub-recipients and contractors, whether such programs or activities are Federally funded or not);
8. Titles II and III of the Americans with Disabilities Act of 1990, which prohibit discrimination on the basis of disability in the operation of public entities, public and private transportation systems, places of public accommodation, and certain testing entities (42 U.S.C. §§ 12131 – 12189) as implemented by Department of Transportation regulations at 49 CFR parts 37 and 38;
9. The Federal Aviation Administration’s Non-discrimination statute (49 U.S.C. § 47123) (prohibits discrimination on the basis of race, color, national origin, and sex);
10. Executive Order 12898, Federal Actions to Address Environmental Justice in Minority Populations and Low-Income Populations, which ensures non-discrimination against minority populations by discouraging programs, policies, and activities with disproportionately high and adverse human health or environmental effects on minority and low-income populations;
11. Executive Order 13166, Improving Access to Services for Persons with Limited English Proficiency, and resulting agency guidance, national origin

discrimination includes discrimination because of limited English proficiency (LEP). To ensure compliance with Title VI, you must take reasonable steps to ensure that LEP persons have meaningful access to your programs (70 Fed. Reg. at 74087 to 74100);

12. Title IX of the Education Amendments of 1972, as amended, which prohibits you from discriminating because of sex in education programs or activities (20 U.S.C. 1681 et seq).

FAA-4.11 Copeland “Anti-Kickback” Act

Contractor must comply with the requirements of the Copeland “Anti-Kickback” Act (18 U.S.C. 874 and 40 U.S.C. 3145), as supplemented by Department of Labor regulation 29 CFR part 3. Contractor and subcontractors are prohibited from inducing, by any means, any person employed on the project to give up any part of the compensation to which the employee is entitled. The Contractor and each Subcontractor must submit to the Owner, a weekly statement on the wages paid to each employee performing on covered work during the prior week. Owner must report any violations of the Act to the Federal Aviation Administration.

FAA-4.12 Energy Conservation Requirements

Contractor and Subcontractor agree to comply with mandatory standards and policies relating to energy efficiency as contained in the state energy conservation plan issued in compliance with the Energy Policy and Conservation Act (42 U.S.C. 6201 et seq).

FAA-4.13 Termination for Default (Construction)

Section 80-09 of FAA Advisory Circular 150/5370-10 establishes conditions, rights and remedies associated with Owner termination of this contract due default of the Contractor.

FAA-4.14 Termination for Default (Equipment)

- A. The Owner may, by written notice of default to the Contractor, terminate all or part of this Contract if the Contractor:
 1. Fails to commence the Work under the Contract within the time specified in the Notice- to-Proceed;
 2. Fails to make adequate progress as to endanger performance of this Contract in accordance with its terms;
 3. Fails to make delivery of the equipment within the time specified in the Contract, including any Owner approved extensions;
 4. Fails to comply with material provisions of the Contract;

5. Submits certifications made under the Contract and as part of their proposal that include false or fraudulent statements;
 6. Becomes insolvent or declares bankruptcy;
- B. If one or more of the stated events occur, the Owner will give notice in writing to the Contractor and Surety of its intent to terminate the contract for cause. At the Owner's discretion, the notice may allow the Contractor and Surety an opportunity to cure the breach or default.
- C. If within [10] days of the receipt of notice, the Contractor or Surety fails to remedy the breach or default to the satisfaction of the Owner, the Owner has authority to acquire equipment by other procurement action. The Contractor will be liable to the Owner for any excess costs the Owner incurs for acquiring such similar equipment.
- D. Payment for completed equipment delivered to and accepted by the Owner shall be at the Contract price. The Owner may withhold from amounts otherwise due the Contractor for such completed equipment, such sum as the Owner determines to be necessary to protect the Owner against loss because of Contractor default.
- E. Owner will not terminate the Contractor's right to proceed with the Work under this clause if the delay in completing the work arises from unforeseeable causes beyond the control and without the fault or negligence of the Contractor. Examples of such acceptable causes include: acts of God, acts of the Owner, acts of another Contractor in the performance of a contract with the Owner, and severe weather events that substantially exceed normal conditions for the location.
- F. If, after termination of the Contractor's right to proceed, the Owner determines that the Contractor was not in default, or that the delay was excusable, the rights and obligations of the parties will be the same as if the Owner issued the termination for the convenience the Owner.
- G. The rights and remedies of the Owner in this clause are in addition to any other rights and remedies provided by law or under this contract.